

bq76PL536A 3～6直列セルのリチウムイオン・バッテリー監視および2次保護アプリケーション用IC

1 特長

- 3～6個の直列セルのサポート、すべての化学方式に対応
- ホットプラグ可能
- データ通信用の高速シリアル・ペリフェラル・インターフェイス(SPI)
- スタック可能な垂直インターフェイス
- デバイス間の絶縁部品が不要
- 工業用温度範囲: -40°C～85°C
- 高精度のA/Dコンバータ(ADC)
 - 標準精度±1mV
 - 14ビット分解能、変換時間6μs
 - 9つのADC入力: 6つのセル電圧、1つの6セル・ブリック電圧、2つの温度、1つの汎用入力
 - 測定同期の専用ピン
- 構成データをECC (Error Check/Correct)付きOTP (One-Time-Programmable)レジスタに保存
- 次の用途に使用可能な組み込みコンパレータ(2次保護)
 - 過電圧および低電圧保護
 - 過熱保護
 - プログラム可能なスレッショルドおよび遅延時間
 - 専用のフォルト出力信号
- 安全性タイムアウト機能付きのセル・バランス制御出力
 - 外部部品によってバランス電流を設定
- 電源電圧範囲: 連続6V～30V、ピーク36V
- 低消費電力
 - スリープ時12μA、アイドル時45μA (標準値)
- 高精度の5V、3mA LDOを搭載

2 アプリケーション

- 無停電電源(UPS)
- 電動自転車、電動スクーター
- 大型バッテリー・システム

3 概要

bq76PL536Aデバイスは、直列に接続された3～6個のリチウムイオン・セル用の、スタック可能なバッテリー・モニタおよびプロテクタです。bq76PL536Aにはアナログ・フロント・エンド(AFE)とともに、高精度のA/Dコンバータ(ADC)が内蔵されており、バッテリー・セルの正確な電圧測定に使用されます。温度測定用には、独立のADCが使用されます。

温度測定に加えて、保護のために過電圧および低電圧もチャンネルごとに監視されます。保護スレッショルドと遅延時間はユーザーがプログラム可能で、これらの値は不揮発性メモリに保存されます。これらのスレッショルドのいずれかを超過した場合、FAULT出力により通知されます。

スタックされたbq76PL536Aデバイスにより、192セルのセル・スタックをサポート可能です。すべてのデバイスは、高速のSPIインターフェイスにより接続されます。

製品情報(1)

型番	パッケージ	本体サイズ(公称)
bq76PL536A	HTQFP (64)	10.00mmx10.00mm

(1) 提供されているすべてのパッケージについては、巻末の注文情報を参照してください。

概略回路図

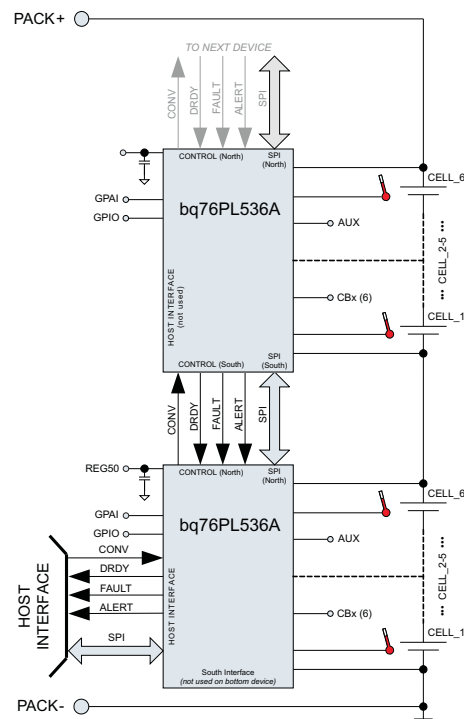

目次

1	特長	1	7.5	Programming	35
2	アプリケーション	1	7.6	Register Maps	37
3	概要	1	8	Application and Implementation	54
4	改訂履歴	2	8.1	Application Information	54
5	Pin Configuration and Functions	4	8.2	Typical Application	55
6	Specifications	6	8.3	Other Schematics	58
6.1	Absolute Maximum Ratings	6	9	Power Supply Recommendations	63
6.2	ESD Ratings	6	9.1	Power Supply Decoupling	63
6.3	Recommended Operating Conditions	7	10	Layout	63
6.4	Thermal Information	7	10.1	Layout Guidelines	63
6.5	Electrical Characteristics	8	10.2	Layout Example	65
6.6	Timing Characteristics – AC SPI Data Interface	12	11	デバイスおよびドキュメントのサポート	66
6.7	Vertical Communications Bus	13	11.1	ドキュメントの更新通知を受け取る方法	66
6.8	Typical Characteristics	14	11.2	コミュニティ・リソース	66
7	Detailed Description	16	11.3	商標	66
7.1	Overview	16	11.4	静電気放電に関する注意事項	66
7.2	Functional Block Diagram	16	11.5	Glossary	66
7.3	Feature Description	17	12	メカニカル、パッケージ、および注文情報	66
7.4	Device Functional Modes	34			

4 改訂履歴

資料番号末尾の英字は改訂を表しています。その改訂履歴は英語版に準じています。

Revision B (January 2016) から Revision C に変更	Page
変更 condition statement from " $V_{BAT} = 20\text{ V}$ " to " $V_{BAT} = 22\text{ V}$ " in <i>Recommended Operating Conditions, Electrical Characteristics and , Timing Characteristics – AC SPI Data Interface</i> tables.....	7
変更 condition statement from " $V_{BAT} = 7.2\text{ V to }30\text{ V}$ " to " $V_{BAT} = 7.2\text{ V to }27\text{ V}$ " in <i>Recommended Operating Conditions ...</i>	7
追加「ドキュメントの更新通知を受け取る方法」セクション.....	66

Revision A (August 2012) から Revision B に変更	Page
「ESD定格」表、「機能説明」セクション、「デバイスの機能モード」セクション、「アプリケーションと実装」セクション、「電源に関する推奨事項」セクション、「レイアウト」セクション、「デバイスおよびドキュメントのサポート」セクション、「メカニカル、パッケージ、および注文情報」セクションを追加.....	1
説明をより簡潔に変更.....	1
Listed values and removed VCn to VCn-1 row.....	6
変更 top two labels with bottom two labels for this row.....	7
削除 FUNCTION_CONFIG[ADCTx]=00 and table note: "ADC specifications valid when device is programmed for 6- μs conversion time per channel, FUNC_CONFIG[ADCT1:0] = 01b" from ADC COMMON SPECIFICATIONS in <i>Electrical Characteristics</i> section.....	9
削除 table note: "ADC is factory trimmed at the conversion speed of $\sim 6\text{ }\mu\text{s}/\text{channel}$ (FUNC_CONFIG[ADCT1:0] = 01b). Use of a different conversion-speed setting may affect measurement accuracy" from Cn (CELL) INPUTS in <i>Electrical Characteristics</i> section.....	10
変更 title to DELAY TIMES.....	11
変更 units in equations to match unit in corresponding row.....	11
変更 name from VC0 to VSS.....	17
追加 CONV_H pin is not used.....	20
追加 TNOM table note.....	25
変更 warning to caution.....	28
変更 text to warning.....	29

• 変更 text to caution and added SLEEP State in text.....	34
• 変更 TS1(2) to TS1:TS2 throughout document.....	35
• 削除 ADC Conversion Timing table.....	50
• 変更 anti-aliasing filter for VC6–VC1.....	54
• 変更 note wording for LDODx.....	63

2011年6月発行のものから更新**Page**

• Changed the pinout image to remove the device number and package type.....	4
--	---

5 Pin Configuration and Functions

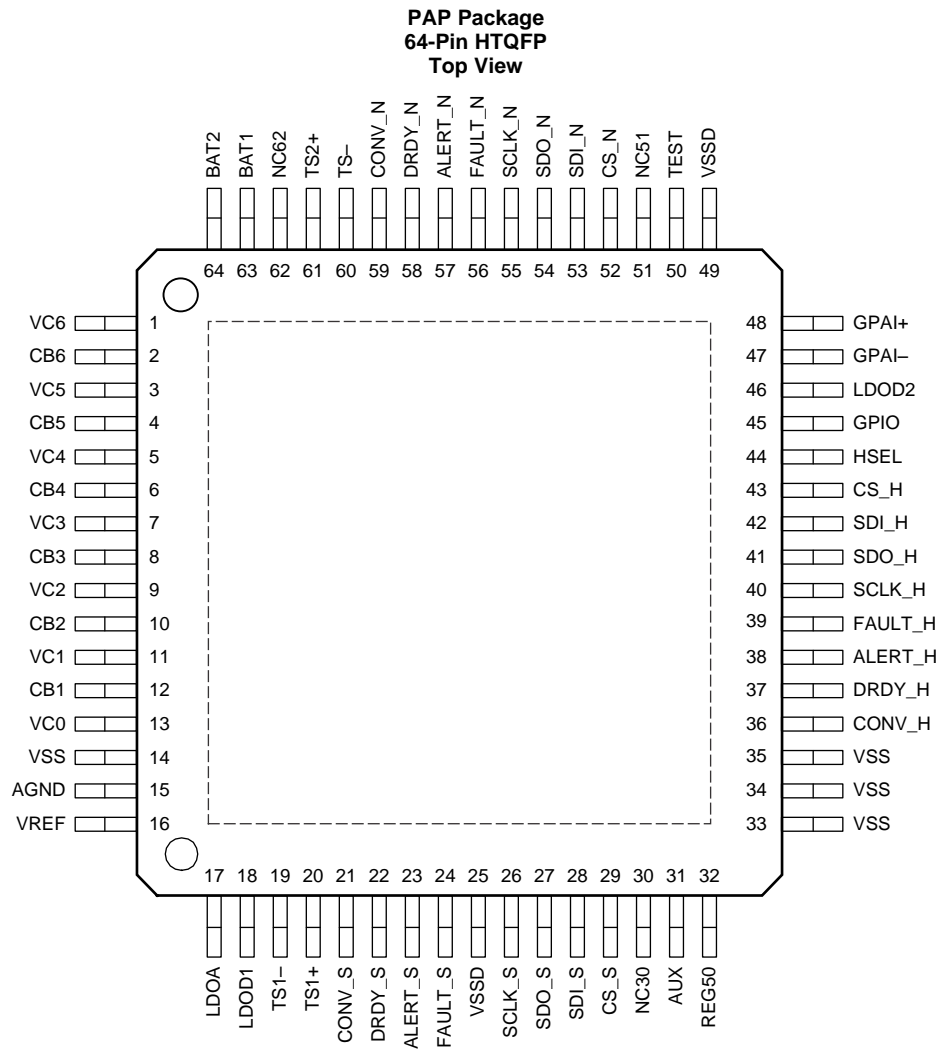

Pin Functions

PIN		TYPE(1)	DESCRIPTION
NAME	NO.		
AGND	15	AI	Internal analog V_{REF} (-)
ALERT_H	38	O	Host-to-device interface – ALERT condition detected in this or higher (North) device
ALERT_N	57	I	Current-mode input indicating a system status change from the next-higher bq76PL536A
ALERT_S	23	OD	Current-mode output indicating a system status change to the next lower bq76PL536A
AUX	31	O	Switched current-limited output from REG50
BAT1	63	P	Power-supply voltage, connect to most-positive cell +, tie to BAT2 on PCB
BAT2	64	P	Power-supply voltage, connect to most-positive cell +, tie to BAT1 on PCB
CB1	12	O	Cell-balance control output 1
CB2	10	O	Cell-balance control output 2
CB3	8	O	Cell-balance control output 3
CB4	6	O	Cell-balance control output 4
CB5	4	O	Cell-balance control output 5
CB6	2	O	Cell-balance control output 6

Pin Functions (continued)

PIN		TYPE(1)	DESCRIPTION
NAME	NO.		
CONV_H	36	I	Host-to-device interface – initiates a synchronous conversion. Pin has 250-nA internal sink to VSS.
CONV_N	59	OD	Current-mode output to the next-higher bq76PL536A to initiate a conversion
CONV_S	21	I	Input from the adjacent lower bq76PL536A to initiate a conversion
CS_H	43	I	Host-to-device interface – active-low chip select from host. Internal 100-k Ω pullup resistor
CS_N	52	OD	Current-mode output used to select the next-higher bq76PL536A for SPI communication
CS_S	29	I	Current-mode input SPI chip-select (slave-select) from the next-lower bq76PL536A
DRDY_H	37	O	Host-to-device interface – conversion complete, data-ready indication
DRDY_N	58	I	Current-mode input indicating conversion data is ready from next-higher bq76PL536A
DRDY_S	22	OD	Current-mode output indicating conversion data is ready to the next lower bq76PL536A
FAULT_H	39	O	Host-to-device interface – FAULT condition detected in this or higher (North) device
FAULT_N	56	I	Current-mode input indicating a system status change from the next-higher bq76PL536A
FAULT_S	24	OD	Current-mode output
GPAI+	48	AI	General-purpose (differential) analog input, connect to VSS if unused.
GPAI–	47	AI	General-purpose (differential) analog input, connect to VSS if unused.
GPIO	45	IOD	Digital open-drain I/O. A 10-k Ω to 2-M Ω pullup is recommended.
HSEL	44	I	Host interface enable, 0 = enable, 1 = disable
LDOA	17	P	Internal analog 5-V LDO bypass connection, requires 2.2- μ F ceramic capacitor for stability
LDOD1	18	P	Internal digital 5-V LDO bypass connection 1, requires 2.2- μ F ceramic capacitor for stability. This pin is tied internally to LDOD2. This pin should be tied to LDOD2 externally.
LDOD2	46	P	Internal digital 5-V LDO bypass connection 2, requires 2.2- μ F ceramic capacitor for stability. This pin is tied internally to LDOD1. This pin should be tied to LDOD1 externally.
NC30	30	–	No connection
NC51	51	–	No connection
NC62	62	–	No connection
REG50	32	P	5-V user LDO output, requires 2.2- μ F ceramic capacitor for stability
SCLK_H	40	I	Host-to-device interface – SPI clock from host
SCLK_N	55	OD	Current-mode output SPI clock to the next-higher bq76PL536A
SCLK_S	26	I	Current-mode input SPI clock from the next-lower bq76PL536A
SDI_H	42	I	Host-to-device interface – data from host to device (host MOSI signal)
SDI_N	53	OD	Current-mode output for SPI data to the next-higher bq76PL536A
SDI_S	28	I	Current-mode input for SPI data from the next-lower bq76PL536A
SDO_H	41	O	Host-to-device interface – data from device to host (host MISO signal), 3-state pin, 250-nA internal pullup
SDO_N	54	I	Current-mode input for SPI data from the next-lower bq76PL536A
SDO_S	27	OD	Current-mode output for SPI data to the next-lower bq76PL536A
TEST	50	I	Factory test pin. Connect to VSS in user circuitry. This pin includes an approximately 100-k Ω internal pulldown
TS1+	20	AI	Differential temperature sensor input
TS1–	19	AI	Differential temperature sensor input
TS2+	61	AI	Differential temperature sensor input
TS2–	60	AI	Differential temperature sensor input
VC0	13	AI	Sense-voltage input terminal for negative terminal of first cell (VSS)
VC1	11	AI	Sense voltage input terminal for positive terminal of the first cell
VC2	9	AI	Sense voltage input terminal for the positive terminal of the second cell
VC3	7	AI	Sense voltage input terminal for the positive terminal of the third cell
VC4	5	AI	Sense voltage input terminal for the positive terminal of the fourth cell
VC5	3	AI	Sense voltage input terminal for the positive terminal of the fifth cell

Pin Functions (continued)

PIN		TYPE(1)	DESCRIPTION
NAME	NO.		
VC6	1	AI	Sense voltage input terminal for the positive terminal of the sixth cell
VREF	16	P	Internal analog voltage reference (+), requires 10- μ F, low-ESR ceramic capacitor to AGND for stability
VSS	14, 33, 34, 35	P	V_{SS}
VSSD	25, 49	P	V_{SS}
Thermal pad	–	–	Thermal pad on bottom of PowerPAD™ package; this must be soldered to similar-size copper area on PCB and connected to VSS, to meet stated specifications herein. Provides heat-sinking to part.

(1) Key: I = digital input, AI = analog input, O = digital output, OD = open-drain output, T = 3-state output, P = power.

6 Specifications

6.1 Absolute Maximum Ratings

over operating free-air temperature range (unless otherwise noted) ⁽¹⁾

		MIN	MAX	UNIT
Supply voltage, V_{MAX}	BAT1 ⁽²⁾	–0.3	36	V
BAT voltage to any other pin	BAT to any pin	–0.3	36	V
Input voltage, V_{IN}	VC1, VC2, VC3, VC4, VC5, VC6	–0.3	36	V
	VC0	–0.3	2	
	TS1+, TS1–, TS2+, TS2–	–0.3	6	
	GPAI	–0.3	6	
	GPIO	–0.3	$V_{REG50} + 0.3$	
	DRDY_N, SDO_N, FAULT_N, ALERT_N	$V_{BAT} - 1$	$V_{BAT} + 2$	
	CONV_S, SDI_S, SCLK_S, CS_S	–2	1	
Output voltage, V_O	CONV_N, SDI_N, SCLK_N, CS_N	–0.3	36	V
	DRDY_S, SDO_S, FAULT_S, ALERT_S	–0.3	5	
	GPIO	–0.3	$V_{REG50} + 0.3$	
	CB1...CB6 (CBREF = 0x00)	–0.3	36	
	REG50, AUX	–0.3	6	
Junction temperature, T_J			150	°C
Storage temperature, T_{stg}		–65	50	°C

(1) Stresses beyond those listed under *Absolute Maximum Ratings* may cause permanent damage to the device. These are stress ratings only, which do not imply functional operation of the device at these or any other conditions beyond those indicated under *Recommended Operating Conditions*. Exposure to absolute-maximum-rated conditions for extended periods may affect device reliability.

(2) All voltages are with respect to VSS of this device except where otherwise noted.

6.2 ESD Ratings

		VALUE	UNIT
$V_{(ESD)}$ Electrostatic discharge	Human-body model (HBM), per ANSI/ESDA/JEDEC JS-001 ⁽¹⁾	± 2000	V
	Charged-device model (CDM), per JEDEC specification JESD22-C101 ⁽²⁾	± 500	

(1) JEDEC document JEP155 states that 500-V HBM allows safe manufacturing with a standard ESD control process.

(2) JEDEC document JEP157 states that 250-V CDM allows safe manufacturing with a standard ESD control process.

6.3 Recommended Operating Conditions

Typical values stated where $T_A = 25^\circ\text{C}$ and $V_{\text{BAT}} = 22\text{ V}$, Min/Max values stated where $T_A = -40^\circ\text{C}$ to 85°C and $V_{\text{BAT}} = 7.2\text{ V}$ to 27 V (unless otherwise noted)

			MIN	NOM	MAX	UNIT
V_{BAT}	Supply voltage	BAT	7.2		27	V
V_I	Input voltage	$\text{VCn}-\text{VC}(n-1)^{(1)}$	1		4.5	V
		GPAI	0		2.5	
		GPIO	0		V_{REG50}	
		$\text{CBn}^{(1)}$	$\text{VC}(n-1)$		VCn	
		TS1+, TS1-, TS2+, TS2-	0		$V_{\text{REG50}}/2$	
		Non-top IC in stack: DRDY_N, SDO_N, FAULT_N, ALERT_N			BAT + 1	
		Top IC in stack: DRDY_N, SDO_N, FAULT_N, ALERT_N			BAT	
		Non-bottom IC in stack: CONV_S, SDI_S, SCLK_S, CS_S			-1	
V_O	Output voltage	Bottom IC in stack: CONV_S, SDI_S, SCLK_S, CS_S			VSS	V
		Non-bottom IC in stack: DRDY_S, SDO_S, FAULT_S, ALERT_S			1	
		Bottom IC in stack: DRDY_S, SDO_S, FAULT_S, ALERT_S			VSS	
		Non-top IC in stack: CONV_N, SDI_N, SCLK_N, CS_N			BAT - 1	
Top IC in stack: CONV_N, SDI_N, SCLK_N, CS_N			BAT			
C_{REG50}	External capacitor	REG50 pin	2.2			μF
C_{VREF}	External capacitor	V_{REF} pin	9.2	10	15	μF
C_{LDO}	External capacitor	LDOx pin	2.2		3.3	μF
T_{OPR}	Operating temperature ⁽²⁾		-40		85	$^\circ\text{C}$

(1) $n = 1$ to 6

(2) Device specifications stated within this range.

6.4 Thermal Information

	THERMAL METRIC ⁽¹⁾	bq76PL536A		UNIT
		PAP (HTQFP)		
		64 PINS		
$R_{\theta\text{JA}}$	Junction-to-ambient thermal resistance	24.6		$^\circ\text{C}/\text{W}$
$R_{\theta\text{JC(top)}}$	Junction-to-case (top) thermal resistance	10		$^\circ\text{C}/\text{W}$
$R_{\theta\text{JB}}$	Junction-to-board thermal resistance	8.1		$^\circ\text{C}/\text{W}$
Ψ_{JT}	Junction-to-top characterization parameter	0.3		$^\circ\text{C}/\text{W}$
Ψ_{JB}	Junction-to-board characterization parameter	8		$^\circ\text{C}/\text{W}$
$R_{\theta\text{JC(bot)}}$	Junction-to-case (bottom) thermal resistance	0.4		$^\circ\text{C}/\text{W}$

(1) For more information about traditional and new thermal metrics, see the [Semiconductor and IC Package Thermal Metrics](#) application report.

6.5 Electrical Characteristics

Typical values stated where $T_A = 25^\circ\text{C}$ and $V_{\text{BAT}} = 22\text{ V}$, Min/Max values stated where $T_A = -40^\circ\text{C}$ to 85°C and $V_{\text{BAT}} = 7.2\text{ V}$ to 27 V (unless otherwise noted)

PARAMETER		TEST CONDITION	MIN	TYP	MAX	UNIT
SUPPLY CURRENT						
ICC _{SLEEP}	Supply current	No load at REG50, SCLK_N, SDI_N, SDO_N, FAULT_N, CONV_N, DRDY_S, ALERT_N, TSx, AUX, or CBx; CB_CTRL = 0; CBT_CONTROL = 0; CONV_H = 0 (not converting), IO_CTRL[SLEEP] = 1		12	20	μA
ICC _{PROTECT}	Supply current	No load at REG50, SCLK_N, SDI_N, SDO_N, FAULT_N, CONV_N, DRDY_S, ALERT_N, TSx, AUX, or CBx; CB_CTRL = 0; CBT_CONTROL = 0; CONV_H = 0 (not converting), IO_CTRL[SLEEP] = 0		45	60	μA
ICCBALANCE	Supply current	No load at REG50, SCLK_N, SDI_N, SDO_N, FAULT_N, CONV_N, DRDY_S, ALERT_N, TSx, or AUX; No DC load at CBx; CB_CTRL ≠ 0; CBT_CONTROL ≠ 0; CONV_H = 0 (not converting), IO_CTRL[SLEEP] = 0		46	60	μA
ICC _{CONVERT}	Supply current	No load at REG50, SCLK_N, SDI_N, SDO_N, FAULT_N, CONV_N, DRDY_S, ALERT_N, TSx or CBx; CONV_S = 1 (conversion active), IO_CTRL[SLEEP] = 0		10.5	15	mA
ICCTSD	Supply current	Thermal shutdown activated; ALERT_STATUS[TSD] = 1		1.6		mA
REG50, INTEGRATED 5-V LDO						
V _{REG50}	Output voltage	I _{REG50OUT} ≤ 0.5 mA, C = 2.2 μF to 22 μF	4.9	5	5.1	V
ΔV _{REG50LINE}	Line regulation	6 V ≤ BAT ≤ 27 V, I _{REG50OUT} = 2 mA		10	25	mV
ΔV _{REG50LOAD}	Load regulation	0.2 mA ≤ I _{REG50OUT} ≤ 2 mA			15	mV
		0.2 mA ≤ I _{REG50OUT} ≤ 5 mA			25	
I _{REG50MAX}	Current limit		12	25	35	mA
I _{AUXMAX}	Maximum load	AUX pin			5	mA
R _{AUX}	AUX output	I = 1 mA, max. capacitance = V _{REG50} Capacitor: C _{VAUX} ≤ C _{VREG50} / 10			50	Ω
LEVEL SHIFT INTERFACE						
I _{NTX1}	North 1 transmitter current	SCLK_N, CS_N, SDI_N, CONV_N	1000	1350	1800	μA
I _{NTX0}	North 0 transmitter current	CS_N, CONV_N			1	μA
I _{NTX0A}	North 0 transmitter current	SCLK_N, SDI_N (BASE device CS_H = 1)			1	μA
I _{NTX0B}	North 0 transmitter current	SCLK_N, SDI_N (BASE device CS_H = 0)	50	75	110	μA
I _{SRX}	South 1 receiver threshold	SCLK_S, CS_S, SDI_S, CONV_S	430	550	680	μA
I _{SRXH}	South receiver hysteresis	SCLK_S, CS_S, SDI_S, CONV_S	50	100	200	μA
I _{STX1}	South 1 transmitter current	ALERT_N, FAULT_S, DRDY_S	800	1100	1400	μA
I _{STX0}	South 0 transmitter current	ALERT_S, FAULT_S, DRDY_S			1	μA
I _{STX0B}	South 0 transmitter current	SDO_S (BASE device CS_H = 0)	1	4	7	μA
I _{NRX}	North 1 receiver threshold	SDO_N, ALERT_N, FAULT_N, DRDY_N	420	580	720	μA
I _{NRXH}	North receiver hysteresis	SDO_N, ALERT_N, FAULT_N, DRDY_N	50	100	200	μA
C _{IN}	Input capacitance			15		pF

Electrical Characteristics (continued)

Typical values stated where $T_A = 25^\circ\text{C}$ and $V_{BAT} = 2.2\text{ V}$, Min/Max values stated where $T_A = -40^\circ\text{C}$ to 85°C and $V_{BAT} = 7.2\text{ V}$ to 27 V (unless otherwise noted)

PARAMETER		TEST CONDITION	MIN	TYP	MAX	UNIT
HOST INTERFACE						
V_{OH}	Logic-level output voltage, high; SDO_H, FAULT_H, ALERT_H, DRDY	$C_L = 20\text{ pF}$, $I_{OH} < 5\text{ mA}^{(1)}$	4.5		V_{LDOD}	V
V_{OL}	Logic-level output voltage, low; SDO_H, FAULT_H, ALERT_H, DRDY	$C_L = 20\text{ pF}$, $I_{OL} < 5\text{ mA}^{(1)}$	VSS		0.5	V
V_{IH}	Logic-level input voltage, high; SCLK_H, SDI_H, CS_H, CONV		2		5.2	V
V_{IL}	Logic-level input voltage, low; SCLK_H, SDI_H, CS_H, CONV		VSS		0.8	V
C_{IN}	Input capacitance SCLK_H, SDI_H, CS_H, CONV			5		pF
I_{LKG}	Input leakage current SCLK_H, SDI_H, CS_H, CONV				1	μA
GENERAL PURPOSE INPUT/OUTPUT (GPIO)						
V_{IH}	Logic-level input voltage, high	$V_{in} \leq V_{REG50}$	2			V
V_{IL}	Logic-level input voltage, low				0.8	V
V_{OH}	Output high-voltage pullup voltage	Supplied by external approximately 100-k Ω resistor			V_{REG50}	V
V_{OL}	Logic-level output voltage, low	$I_{OL} = 1\text{ mA}$	0.3			V
C_{IN}	Input capacitance(1)			5		pF
I_{LKG}	Input leakage current				1	μA
CELL BALANCING CONTROL OUTPUT (CBx)						
CB_z	Output impedance	$1\text{ V} < V_{CELL} < 5\text{ V}$	80	100	120	k Ω
V_{RANGE}	Output V		V_{Cn-1}		V_{Cn}	V
ADC COMMON SPECIFICATIONS						
t_{CONV_START}	CONV high to conversion start ^{(2) (3)}	ADC_CONTROL[ADC_ON] = 1	5.4	6	6.6	μs
		ADC_CONTROL[ADC_ON] = 0		500		μs
t_{CONV}	Conversion time per selected channel ⁽⁴⁾	ADC_CONTROL[ADC_ON] = 1	5.4	6	6.6	μs
I_{LKG}	Input leakage current	Not converting		<10	100	nA
VCn (CELL) INPUTS						
V_{IN}	Input voltage range ⁽⁵⁾	$V_{Cn} - V_{Cn-1}$, where $n = 1$ to 6	0		6	V
V_{RES}	Voltage resolution ⁽⁶⁾	14 bits		~378		μV
V_{ACC}	Voltage accuracy, total error, $V_{IN} = V_{Cn}$ to V_{Cn-1}	$-10^\circ\text{C} \leq T_A \leq 50^\circ\text{C}$, $1.2\text{ V} < V_{IN} < 4.5\text{ V}$	-5	± 1	5	mV
		$-40^\circ\text{C} \leq T_A \leq 85^\circ\text{C}$, $1.2\text{ V} < V_{IN} < 4.5\text{ V}$	-8		8	

(1) Total simultaneous current drawn from all pins is limited by LDOD current to $\leq 10\text{ mA}$.

(2) If ADC_CONTROL[ADC_ON] = 0, add 500 μs to conversion time to allow ADC subsystem to stabilize. This is self-timed by the part.

(3) Additional 50 ms (POR) is required before first conversion after a) initial cell connection; or b) V_{BAT} falls below V_{POR} .

(4) Plus t_{CONV_START} , that is, if device is programmed for six channel conversions, total time is approximately $6 \times 6 + 6 = 42\text{ }\mu\text{s}$.

(5) 0 V may not lie within the range of measured values due to offset voltage limit and device calibration.

(6) See text for specific conversion formula.

Electrical Characteristics (continued)

Typical values stated where $T_A = 25^\circ\text{C}$ and $V_{\text{BAT}} = 22\text{ V}$, Min/Max values stated where $T_A = -40^\circ\text{C}$ to 85°C and $V_{\text{BAT}} = 7.2\text{ V}$ to 27 V (unless otherwise noted)

PARAMETER		TEST CONDITION	MIN	TYP	MAX	UNIT
R_{IN}	Effective input resistance	Converting		2		$\text{M}\Omega$
C_{IN}	Input capacitance	Converting		1		pF
E_{N}	Noise	$V_{\text{IN}} = 3\text{ V}$			250	μV_{RMS}
V_{BAT} (V_{BRICK}) MEASUREMENT						
V_{IN}	Input voltage range ⁽⁵⁾ , BATn to VSS	FUNCTION_CONFIG = 0101xx00b	0		30	V
V_{RES}	Voltage resolution ⁽⁶⁾	14 bits		~1.831		mV
V_{ACC}	Voltage accuracy	Total error	-80	-30	20	mV
C_{IN}	Input capacitance	Converting		1		pF
R_{IN}	Effective input resistance	Converting		50		$\text{k}\Omega$
E_{N}	Noise				1.5	mV_{RMS}
GPAI MEASUREMENT						
V_{IN}	Input voltage range ⁽⁵⁾ , GPAI+ to GPAI-		0		2.5	V
V_{RES}	Voltage resolution ⁽⁶⁾	14 bits		-153		μV
V_{ACC}	Voltage accuracy, $V_{\text{IN}} = \text{GPAI+} - \text{GPAI-}$	$0.25\text{ V} \leq V_{\text{IN}} \leq 2.5\text{ V}$ $V_{\text{IN}} = 1.25\text{ V}$, $T_A = 25^\circ\text{C}$	-7		7	mV
C_{IN}	Input capacitance	Converting		40		pF
R_{IN}	Effective input resistance	Converting		50		$\text{k}\Omega$
E_{N}	Noise				150	μV_{RMS}
TSn MEASUREMENT						
V_{RES}	Voltage resolution ⁽⁶⁾	14 bits, REG50 = 5 V, (Resolution $\approx V_{\text{REG50}} / 2^{15}$)		-153		μV
V_{ACC}	Ratio accuracy, % of input ⁽⁶⁾	$0.25\text{ V} \leq V_{\text{IN}} \leq 2.4\text{ V}$	-0.7%	$\pm 0.2\%$	0.7%	
C_{IN}	Input capacitance	Converting		40		pF
R_{IN}	Effective input resistance	Converting		50		$\text{k}\Omega$
E_{N}	Noise				150	μV_{RMS}
THERMAL SHUTDOWN						
T_{SD}	Shutdown threshold	$V_{\text{BAT}} = 20\text{ V}$	125	142	156	$^\circ\text{C}$
T_{HYS}	Recovery hysteresis			8	25	$^\circ\text{C}$
UNDERVOLTAGE LOCKOUT (UVLO) and POWER-ON RESET (POR)						
V_{UVLO}	Negative-going threshold		5		5.6	V
$V_{\text{UVLO_HSY}}$	Hysteresis		250	375	500	mV
$\text{UVLO}_{\text{DELAY}}$	Delay to locked-out condition	$V \leq V_{\text{UVLO MIN}}$		15		μs
V_{POR}	Negative-going threshold		4		5	V
$V_{\text{POR_HSY}}$	Hysteresis		250	500	750	mV
$\text{POR}_{\text{DELAY}}$	Delay to disabled condition	$V \leq V_{\text{POR MIN}}$		15		μs
t_{RST}	Reset delay time	$V \geq V_{\text{POR}} + V_{\text{POR_HSY}}$	40	56	70	ms
$V_{\text{DELTA_RISE}}$	Voltage delta between trip points	$V_{\text{UVLO}} - V_{\text{POR}}$ (V_{BAT} rising)	0.3	0.4	0.7	V

Electrical Characteristics (continued)

Typical values stated where $T_A = 25^\circ\text{C}$ and $V_{\text{BAT}} = 22\text{ V}$, Min/Max values stated where $T_A = -40^\circ\text{C}$ to 85°C and $V_{\text{BAT}} = 7.2\text{ V}$ to 27 V (unless otherwise noted)

PARAMETER		TEST CONDITION	MIN	TYP	MAX	UNIT
$V_{\text{DELTA_FALL}}$	Voltage delta between trip points	$V_{\text{UVLO}} - V_{\text{POR}}$ (V_{BAT} falling)	0.4	0.52	0.7	V
BATTERY PROTECTION THRESHOLDS						
V_{OVR}	OV detection threshold range ⁽⁷⁾		2		5	V
ΔV_{OVS}	OV detection threshold program step			50		mV
V_{OVH}	OV detection hysteresis			50		mV
V_{OVA1}	OV detection threshold accuracy	$3.3 \leq V_{\text{OV_SET}} \leq 4.5$	-50	0	50	mV
V_{OVA2}	OV detection threshold accuracy	$V_{\text{OV_SET}} < 3.3$ or $V_{\text{OV_SET}} > 4.5$	-70	0	70	mV
V_{UVR}	UV detection threshold range ⁽⁷⁾		700		3300	mV
ΔV_{UVS}	UV detection threshold program step			100		mV
V_{UVH}	UV detection hysteresis			100		mV
V_{UVA}	UV detection threshold accuracy		-100	0	100	mV
V_{OTR}	OT detection threshold range ⁽⁸⁾	$V_{\text{REG50}} = 5\text{ V}$	1		2	V
ΔV_{OTS}	OT detection threshold program step ⁽⁸⁾			See ⁽⁹⁾		V
V_{OTA}	OT detection threshold accuracy ⁽⁸⁾	$T = 40^\circ\text{C}$ to 90°C		0.04	0.05	V
ΔV_{OTH}	OT reset hysteresis	$T = 40^\circ\text{C}$ to 90°C	8%	12%	15%	
BATTERY PROTECTION DELAY TIMES						
t_{OV}	OV detection delay-time range		0		3200	ms
Δt_{OV}	OV detection delay-time step	COVT [μs] = 0		100		μs
		COVT [ms] = 1		100		ms
t_{UV}	UV detection delay-time range		0		3200	ms
Δt_{UV}	UV detection delay-time step	CUVT[7] (μs) = 0		100		μs
		CUVT[7] (ms) = 1		100		ms
t_{OT}	OT detection delay-time range		0		2550	ms
Δt_{OT}	OT detection delay-time step			10		ms
t_{acr}	OV, UV, and OT detection delay-time accuracy ⁽¹⁰⁾	CUVT, (COVT) $\geq 500\ \mu\text{s}$	-12%	0%	10%	
$t_{\text{(DETECT)}}$	Protection comparator detection time	V_{OT} or V_{OV} or V_{UV} threshold exceeded by 10 mV			100	μs

(7) COV and CUV thresholds must be set such that $\text{COV} - \text{CUV} \geq 300\text{ mV}$.

(8) Using recommended components. Consult 表 2 in text for voltage levels used.

(9) See 表 2 for trip points.

(10) Under double or multiple fault conditions (of a single type), the second or greater fault may have its delay time shortened by up to the step time for the fault. For example, the second and subsequent COV faults occurring within the delay time period for the first fault may have their delay time shortened by up to 100 μs .

Electrical Characteristics (continued)

Typical values stated where $T_A = 25^\circ\text{C}$ and $V_{\text{BAT}} = 22\text{ V}$, Min/Max values stated where $T_A = -40^\circ\text{C}$ to 85°C and $V_{\text{BAT}} = 7.2\text{ V}$ to 27 V (unless otherwise noted)

PARAMETER		TEST CONDITION	MIN	TYP	MAX	UNIT
OTP EPROM PROGRAMMING CHARACTERISTICS						
V_{PROG}	Programming voltage	$V_{\text{BAT}} \geq 20\text{ V}$	6.75	7	7.25	V
t_{PROG}	Programming time	$V_{\text{BAT}} \geq 20\text{ V}$			(11)50	ms
I_{PROG}	Programming current	$V_{\text{BAT}} \geq 20\text{ V}$		10	20	mA

(11) The write pulse is self-timed internally. V_{PROG} should be applied for this time at a minimum.

6.6 Timing Characteristics – AC SPI Data Interface

Typical values stated where $T_A = 25^\circ\text{C}$ and $V_{\text{BAT}} = 22\text{ V}$, Min/Max values stated where $T_A = -40^\circ\text{C}$ to 85°C and $V_{\text{BAT}} = 7.2\text{ V}$ to 27 V (unless otherwise noted), see [Figure 1](#).

PARAMETER		TEST CONDITION	MIN	NOM	MAX	UNIT
f_{SCLK}	SCLK frequency ⁽¹⁾		10	250	1000	kHz
SCLK_{DC}	SCLK_H duty cycle, $t_{\text{HIGH}} / t_{\text{SCLK}}$ or $t_{\text{LOW}} / t_{\text{SCLK}}$		40%		60%	
$t_{\text{CS,LEAD}}$	CS_H lead time, CS_H low to clock		50	SCLK/2		ns
$t_{\text{CS,LAG}}$	CS_H lag time. Last clock to CS_H high		10	SCLK/2		ns
$t_{\text{CS,DLY}}$	CS_H high to CS_H low (inter-packet delay requirement)		3			μs
t_{ACC}	CS_H access time ⁽²⁾ : CS_H low to SDO_H data out			125	250	ns
t_{DIS}	CS_H disable time ⁽²⁾ : CS_H high to SDO_H high impedance			2.5	2.7	μs
$t_{\text{SU,SDI}}$	SDI_H input-data setup time		15			ns
$t_{\text{HD,SDI}}$	SDI_H input-data hold time		10			ns
$t_{\text{VALID,SDO}}$	SDO_H output-data valid time SCLK_H edge to SDO_H valid	$C_L \leq 20\text{ pF}$		75	110	ns

- (1) Maximum SCLK frequency is limited by the number of bq76PL536A devices in the vertical stack. The maximum listed here may not be realizable in systems due to delays and limits imposed by other components including wiring, connectors, PCB material and routing, and so forth. See text for details.
- (2) Time listed is for single device.

6.7 Vertical Communications Bus

Typical values stated where $T_A = 25^\circ\text{C}$ and $V_{BAT} = 20\text{ V}$ (unless otherwise noted)

PARAMETER	TEST CONDITIONS	MIN	TYP ⁽¹⁾	MAX	UNIT
t_{HV_SCLK}	Propagation delay, SCLK_H to SCLK_N		40		ns
t_{VB_SCLK}	Propagation delay, SCLK_S to SCLK_N		30		ns
t_{HV_CS}	Propagation delay, CS_H to CS_N		40		ns
t_{VB_CS}	Propagation delay, CS_S to CS_N		30		ns
t_{HV_SDI}	Propagation delay, SDI_H to SDI_N		40		ns
t_{VB_SDI}	Propagation delay, SDI_S to SDI_N		30		ns
t_{HV_CONV}	Propagation delay, CONV_H to CONV_N		100		ns
t_{VB_CONV}	Propagation delay, CONV_S to CONV_N		30		ns
t_{HV_SDO}	Propagation delay, SDO_N to SDO_H		10		ns
t_{VB_SDO}	Propagation delay, SDO_N to SDO_S		40		ns
t_{HV_DRDY}	Propagation delay, DRDY_N to DRDY_H		60		ns
t_{VB_DRDY}	Propagation delay, DRDY_N to DRDY_S		40		ns
t_{HV_FAULT}	Propagation delay, FAULT_N to FAULT_H		55		ns
t_{VB_FAULT}	Propagation delay, FAULT_N to FAULT_S		30		ns
t_{HV_ALERT}	Propagation delay, ALERT_N to ALERT_H		65		ns
t_{VB_ALERT}	Propagation delay, ALERT_N to ALERT_S		30		ns

(1) Typical values are quoted in place of MIN/MAX for design guidance only. Actual propagation delay depends heavily on wiring and capacitance in the signal path. These parameters are not tested in production due to these dependencies on system design considerations.

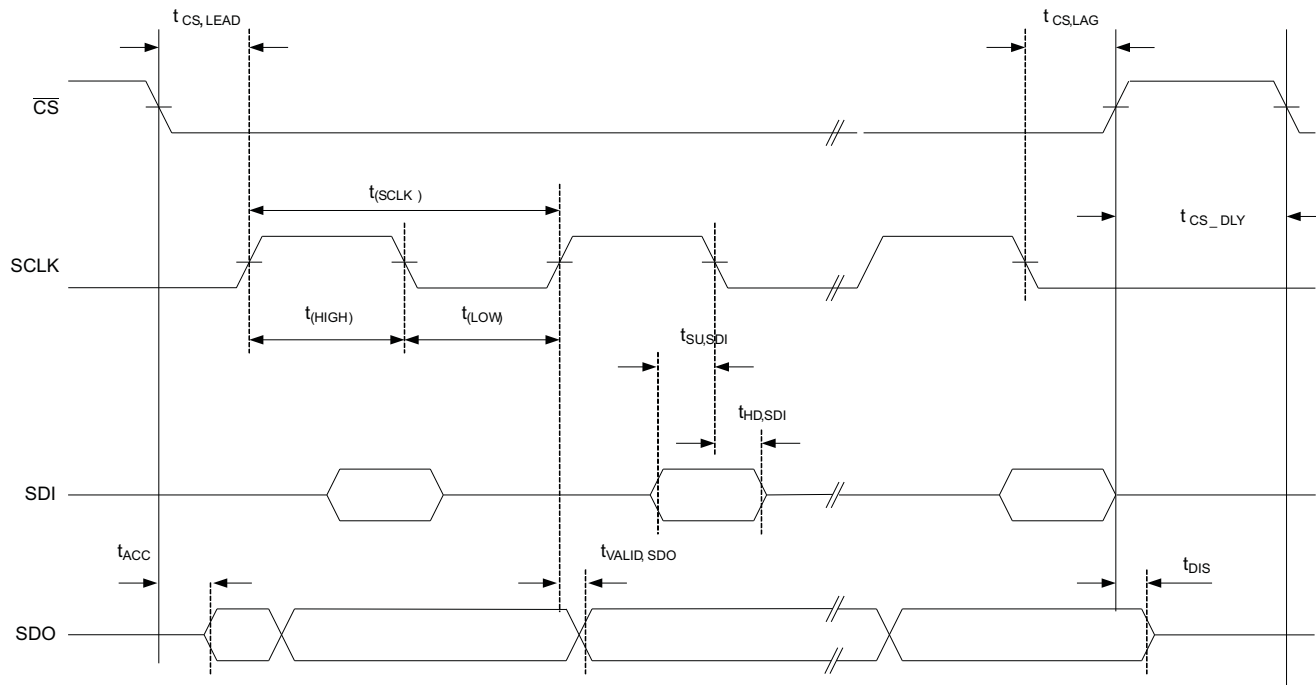

FIG 1. SPI Host Interface Timing

6.8 Typical Characteristics



图 2. Total Channel Accuracy (V) for VCELL1



图 3. Total Channel Accuracy (V) for VCELL2

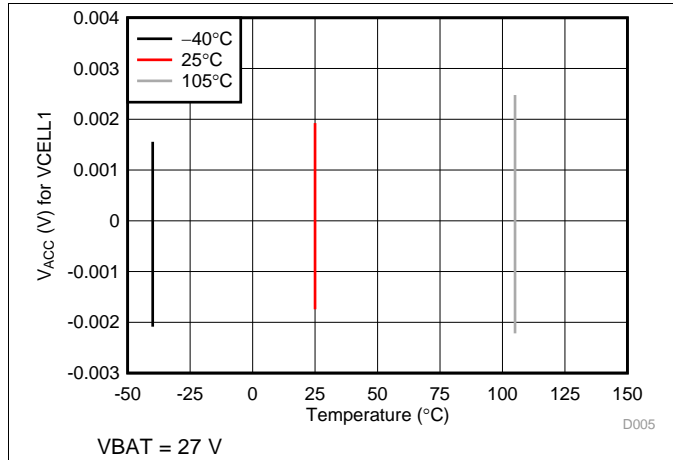

图 4. Total Channel Accuracy (V) for VCELL3

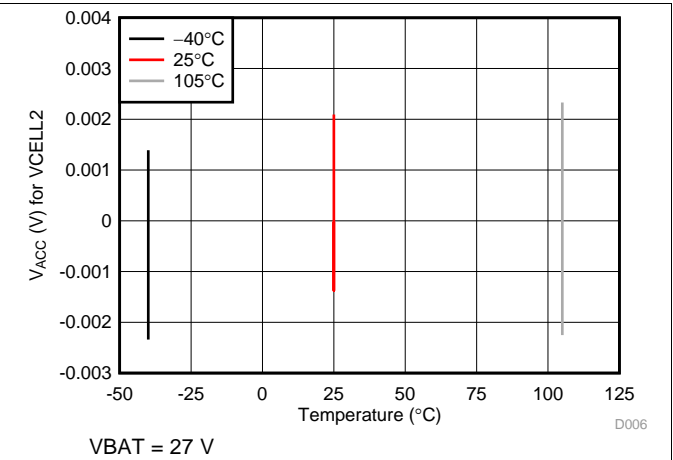

图 5. Total Channel Accuracy (V) for VCELL4

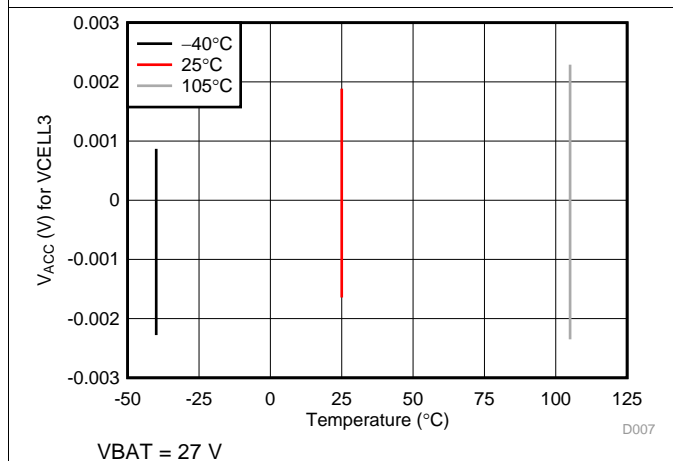

图 6. Total Channel Accuracy (V) for VCELL5

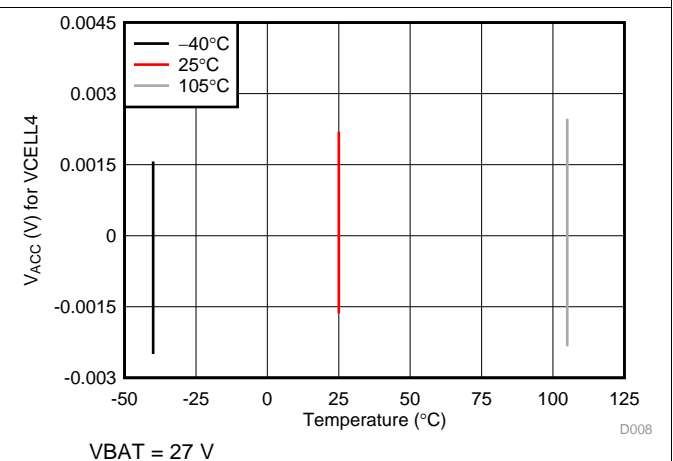

图 7. Total Channel Accuracy (V) for VCELL6

Typical Characteristics (continued)

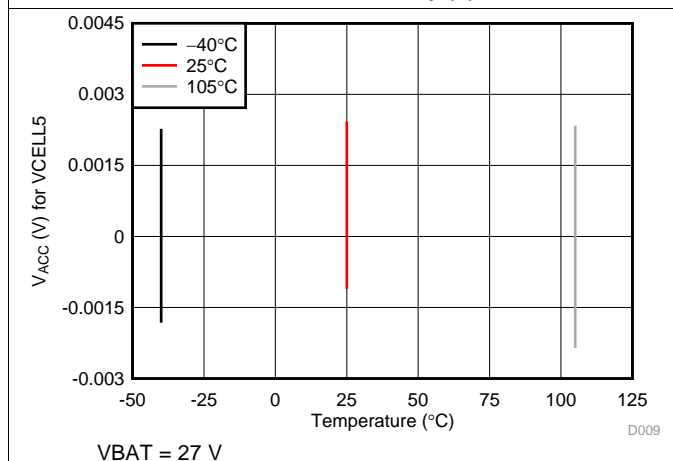

7 Detailed Description

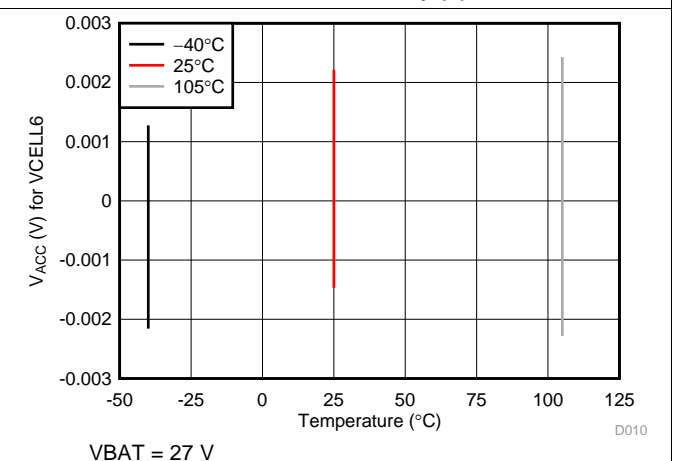
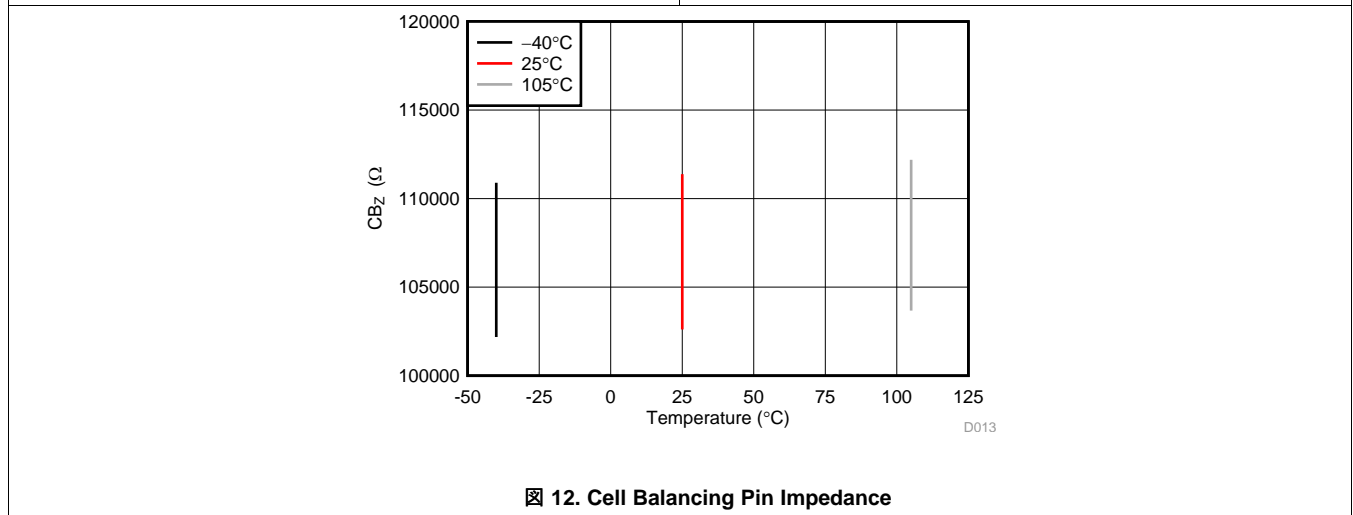
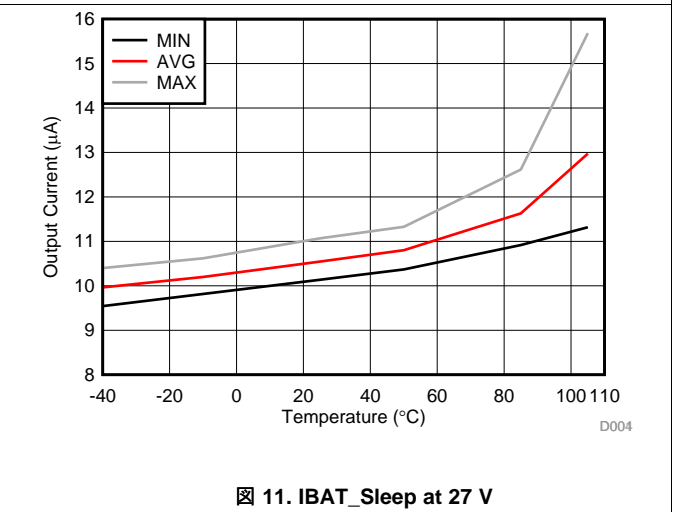
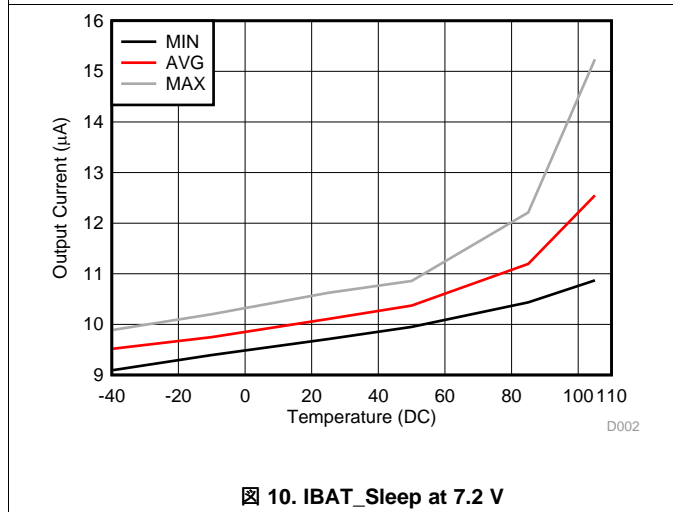
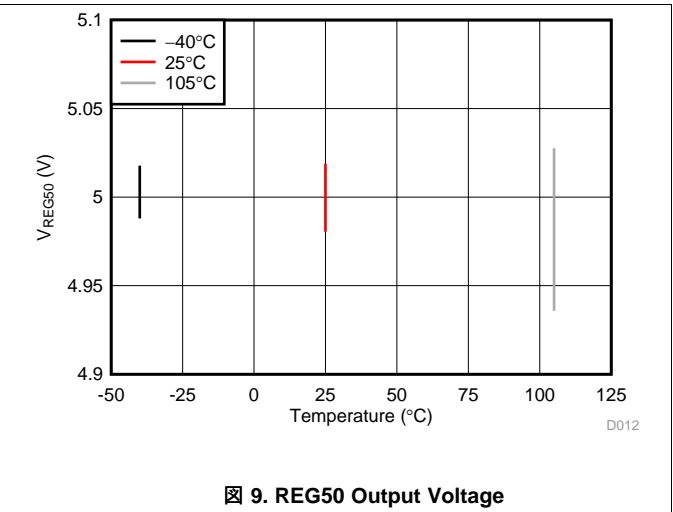
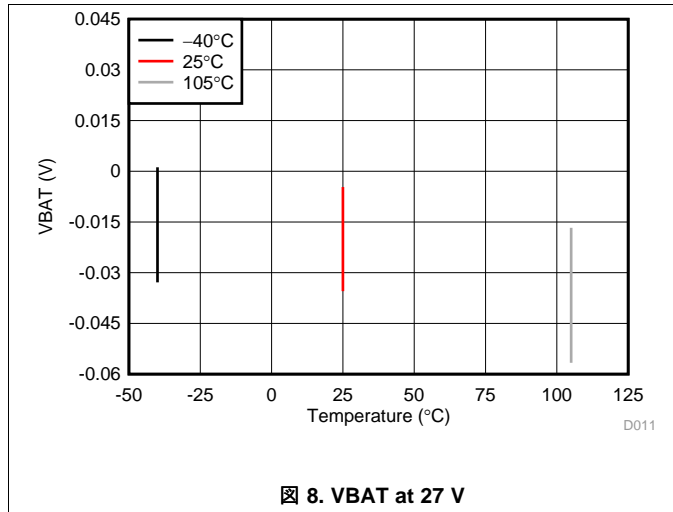
7.1 Overview

The bq76PL536A (*Functional Block Diagram*) is a 3-to-6 series Lithium-ion battery monitor, secondary protector and analog front end (AFE) that can be stacked vertically to monitor up to 192 cells without the need for additional isolation components between ICs.

This device incorporates a precision analog-to-digital converter (ADC); independent cell voltage and temperature protection; cell balancing, and precision 5-V regulator to power user circuitry. The bq76PL536A additionally provides full (secondary) protection for overvoltage, undervoltage, and overtemperature conditions.

7.2 Functional Block Diagram

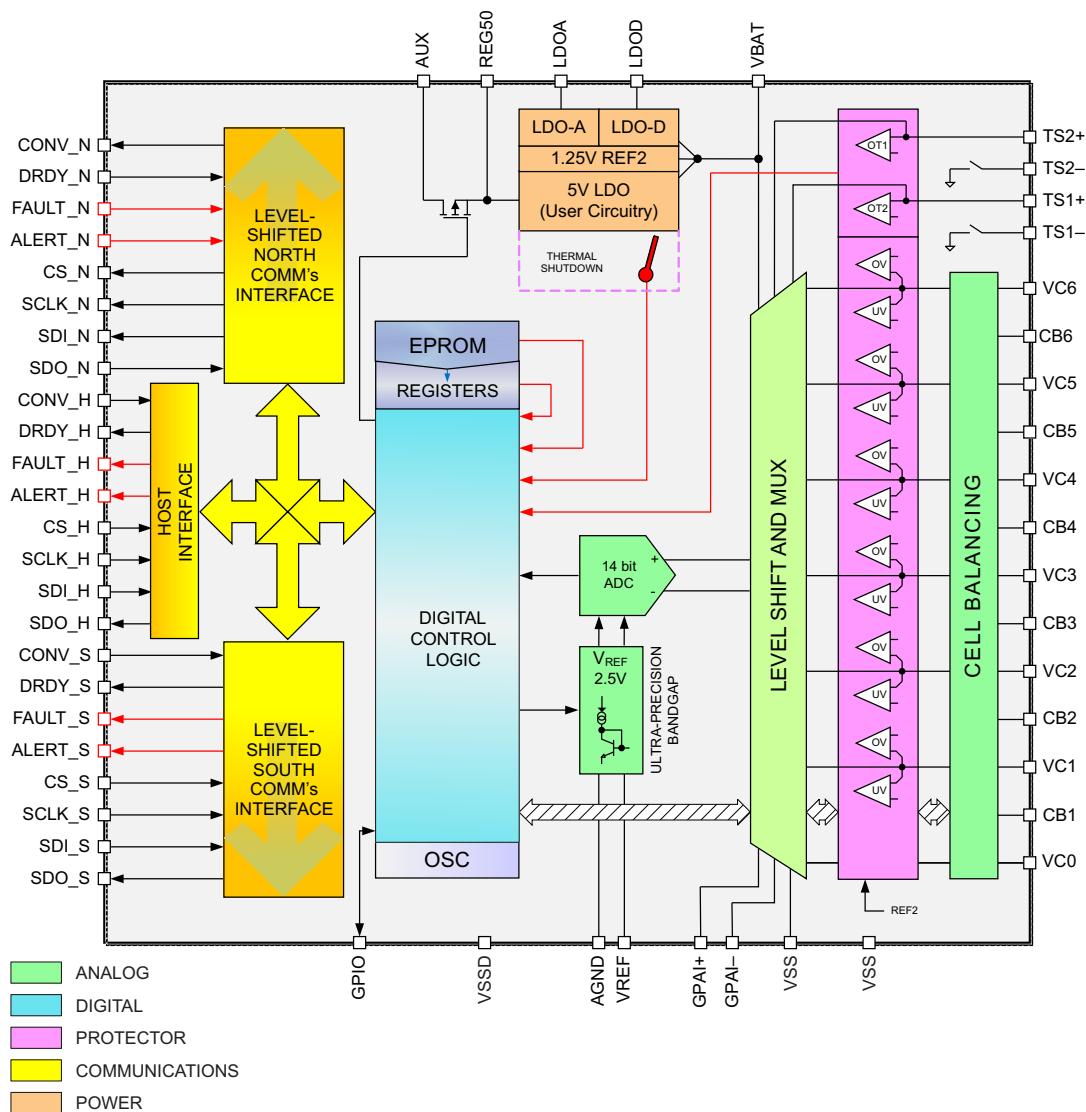

13. bq76PL536A Block Diagram

7.3 Feature Description

7.3.1 Analog-to-Digital Conversion (ADC)

7.3.1.1 General Features

The integrated 14-bit (unsigned) high-speed successive approximation register (SAR) analog-to-digital converter uses an integrated band-gap reference voltage (V_{REF}) for the cell and brick measurements. The ADC has a front-end multiplexer for nine inputs – six cells, two temperature sensors, and one general-purpose analog input (GPAI). The GPAI input can further be multiplexed to measure the *brick* voltage between the BATx pin and VSS or the voltage between the GPAI+ and GPAI– pins.

The ADC and reference are factory trimmed to compensate for gain, offset, and temperature-induced errors for all inputs. The measurement result is not allowed to roll over due to offset error at the top and bottom of the range. For example, a reading near zero does not underflow to 0x03ff due to offset error, and vice-versa.

The converter returns 14 valid unsigned magnitude bits in the following format:

<00xxxxxx xxxxxxxx>

Each word is returned in big-endian format in a register pair consisting of two adjacent 8-bit registers. The MSB of the word is located in the lower-address register of the pair, that is, data for cell 1 is returned in registers 0x03 and 0x04 as 00xxxxxx xxxxxxxxb.

7.3.1.2 3-to-6 Series Cell Configuration

When fewer than 6 cells are used, the most-positive cell voltage of the series string should be connected to the BAT1/BAT2 pins, through the RC input network shown in the [Typical Application](#) section. Unused VCx inputs should be connected to the next VCx input down until an input connected to a cell is reached – that is, in a four cell stack, VC6 connects to VC5, which connects to VC4 (☒ 14).

The internal multiplexer control can be set to scan only the inputs which are connected to cells, thereby speeding up conversions slightly. The multiplexer is controlled by the ADC_CONTROL[CN2:0] bits.

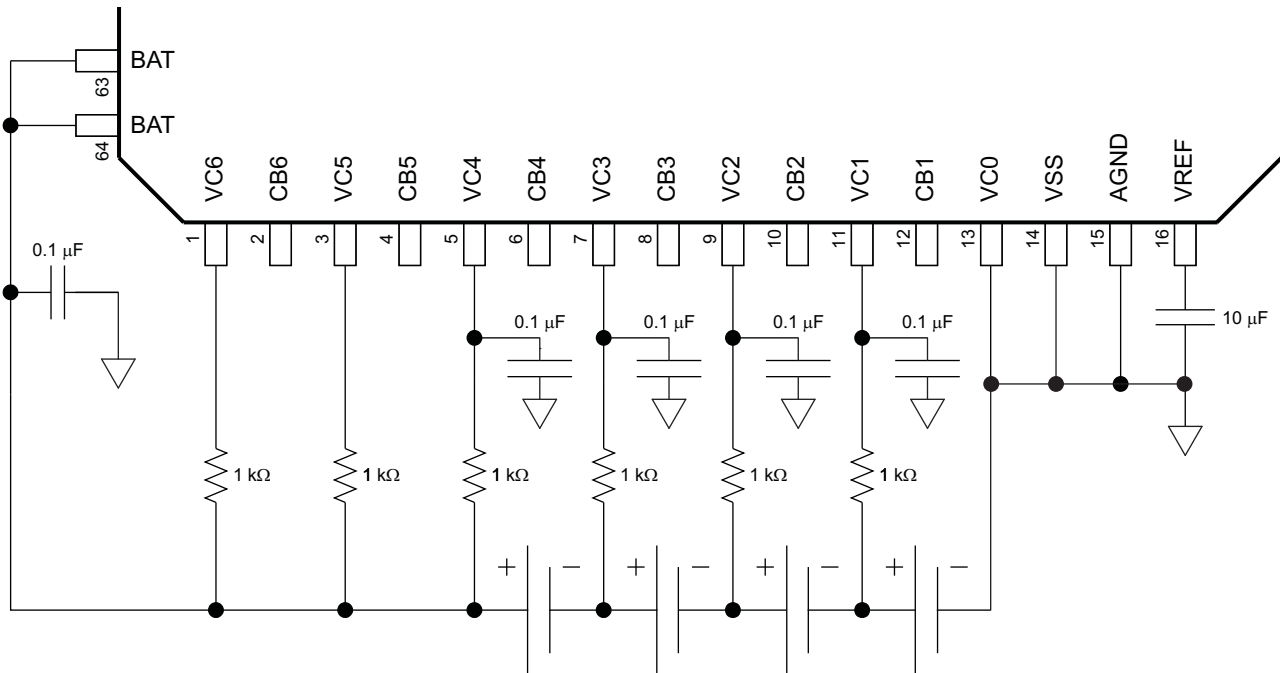

☒ 14. Connecting < 6 Cells (4 Shown)

Feature Description (continued)

7.3.1.3 Cell Voltage Measurements

Use the following formula (all values are in decimal) to convert the returned cell measurement value to a dc voltage (in mV).

$$\text{mV} = (\text{REG}_{\text{MSB}} \times 256 + \text{REG}_{\text{LSB}}) \times 6250 / 16383 \quad (1)$$

Example:

```
Cell_1 == 3.35 V (3350 mV);
After conversion, REG_03 == 0x22; REG_04 == 0x4d
0x22 x 0x100 + 0x4d = 0x224d (8781.)
8781 x 6250 / 16,383 = 3349.89 mV ≈ 3.35 V
```

7.3.1.4 GPAI or V_{BAT} Measurements

The bq76PL536A features a differential input to the ADC from two external pins, GPAI+ and GPAI-. The ADC GPAI result register can be configured (via the FUNCTION_CONFIG[GPAI_SRC] to provide a measurement of the voltage on these two pins, or of the *brick* voltage present between the BATx pins and VC0.

In the bq76PL536A device, the V_{BAT} measurement is taken from the BATx pin to the VC0 pin, and is a separate input to the ADC mux. Because this is a separate input to the ADC, certain common system faults, such as a broken cell wire, can be easily detected using the bq76PL536A and simple firmware techniques.

The GPAI measurement can be configured to use one of two references via FUNCTION_CONFIG[GPAI_REF]. Either the internal bandgap (V_{REF}) or REG50 can be selected. When REG50 is selected, the ADC returns a ratio of the voltage at the inputs and REG50, removing the need for compensation of the REG50 voltage accuracy or drift when used as a source to excite the sensor. When the device is configured to measure V_{BAT} (FUNCTION_CONFIG[GPAI_SRC] = 1), the device selects VREF automatically and ignores the FUNCTION_CONFIG[GPAI_REF] setting.

7.3.1.4.1 Converting GPAI Result to Voltage

To convert the returned GPAI measurement value to a voltage using the internal band-gap reference (FUNCTION_CONFIG[GPAI_REF] = 1), the following formula is used.

$$\text{mV} = (\text{REG}_{\text{MSB}} \times 256 + \text{REG}_{\text{LSB}}) \times 2500 / 16,383$$

- FUNCTION_CONFIG = 0100 xxxxb (2)

Example:

```
The voltage connected to the GPAI inputs == 1.25 V;
After conversion, REG_01 == 0x20; REG_02 == 0x00
0x20 x 0x100 + 0x00 = 0x2000 (8192.)
8192 x 2500 / 16,383 = 1250 mV
```

7.3.1.4.2 Converting VBAT Result to Voltage

To convert the returned V_{BAT} measurement value to a voltage, the following formula is used.

$$V = (\text{REG}_{\text{MSB}} \times 256 + \text{REG}_{\text{LSB}}) \times 33.333 / 2^{14} \quad (33.333 \approx 6.25 / 0.1875)$$

- FUNCTION_CONFIG = 0101 xxxxb (3)

Example:

```
The sum of the series cells connected to VC6–VC0 == 20.295 V;
After conversion, REG_01 == 0x26; REG_02 == 0xf7
0x26 x 0x100 + 0xf7 = 0x26f7 (9975.)
9975 x 33.333 / 16,383 = 20.295 V
```

Feature Description (continued)

7.3.1.5 Temperature Measurement

The bq76PL536A can measure the voltage TS1+, TS1– and TS2+, TS2– differential inputs using the ADC. An external thermistor or resistor divider network typically drives these inputs. The TSn inputs use the REG50 output divided down and internally connected as the ADC reference during conversions. This produces a ratiometric result and eliminates the need for compensation or correction of the REG50 voltage drift when used to drive the temperature sensors. The REG50 reference allows an approximate 2.5-V full-scale input at the TSn inputs. The final reading is limited between 0 and 16383, corresponding to an external ratio of 0 to 0.5.

Two control bits are required for the ADC to convert the TSn input voltages successfully. ADC_CONTROL[TSn] is set to cause the ADC to convert the TSn channel on the next requested conversion cycle. IO_CONTROL[TSn] is set to cause the FET switch connecting the TSn– input to VSS to close, completing the circuit of the voltage divider. The IO_CONTROL bits should only be set as needed to conserve power; at high temperatures, thermistor excitation current may be relatively high.

7.3.1.5.1 External Temperature Sensor Support (TS1+, TS1–, TS2+, and TS2–)

The device is intended for use with a nominal 10 kΩ at 25°C NTC external thermistor (AT103 equivalent) such as the Panasonic ERT-J1VG103FA, a 1% device. A suitable external resistor-capacitor network should be connected to position the response of the thermistor within the range of interest. This is typically $R_T = 1.47$ kΩ and $R_B = 1.82$ kΩ (1%) as shown in [Figure 15](#). A parallel bypass capacitor in the range 1 nF to 47 nF placed across the thermistor should be added to reduce noise coupled into the measurement system. The response time delay created by this network should be considered when enabling the respective TS input prior to conversion and setting the OT delay timer. See [Figure 15](#) for details.

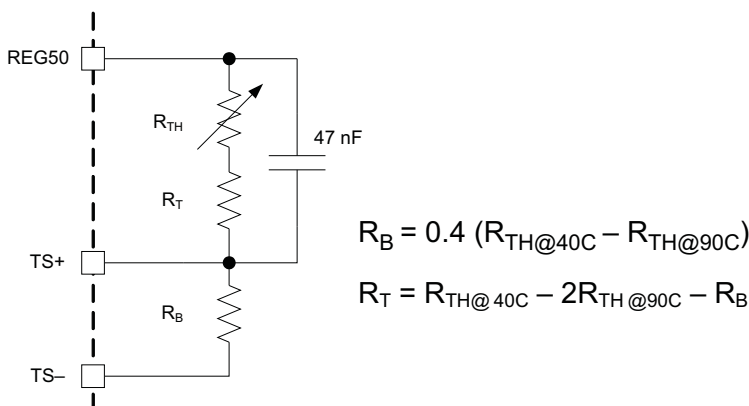

Figure 15. Thermistor Connection

7.3.1.5.2 Converting TSn Result to Voltage (Ratio)

To convert the returned TSn measurement value to a ratio, $R_{TS} = V_{TS} \cdot \text{REG50}$, the following formulas are used. The setting FUNCTION_CONFIG = 0100 xxxxb is assumed. Note that the offset and gain correction are slightly different for each channel.

$$\text{ADC behavior: COUNT} = (V_{TSn} / \text{REG50} \times \text{scalar}) - \text{OFFSET} \quad (4)$$

$$\text{TS1: } R_{TS1} = ((\text{TEMPERATURE1_H} \times 256 + \text{TEMPERATURE1_L}) + 2) / 33,046 \quad (5)$$

Example:

The voltage connected to the TS1 inputs (TS1+ – TS1–) == 0.661 V; $V_{\text{REG50}} \approx 5$ V nominal

After conversion, $\text{REG}_{\text{MSB}} == 0x11$; $\text{REG}_{\text{LSB}} == 0x16$

ACTUAL_COUNT = $0x11 \times 0x100 + 0x16 = 0x1116$ (4374.)

$(4374 + 2) / 33,046 = 0.1324$ (ratio of TSn inputs to REG50)

$0.1324 \times \text{REG50} = 0.662$ V

Feature Description (continued)

7.3.1.6 ADC Band-Gap Voltage Reference

The ADC and protection subsystems use separate and independent internal voltage references. The ADC band gap (V_{REF}) is nominally 2.5 V. The reference is temperature-compensated and stable.

The internal reference is brought out to the VREF pin for bypassing. A high quality 10- μ F capacitor should be connected between the VREF and AGND pins, in very close physical proximity to the device pins, using short track lengths to minimize the effects of track inductance on signal quality. The AGND pin should be connected to VSS. Device VSS connections should be brought to a single point close to the IC to minimize layout-induced errors. The device tab should also be connected to this point, and is a convenient common VSS location. The internal VREF should not be used externally to the device by user circuits.

7.3.1.7 Conversion Control

7.3.1.7.1 Convert Start

Two methods are available to start a conversion cycle. The CONV_H pin may be asserted, or firmware may set the CONVERT_CTRL[CONV] bit.

7.3.1.7.1.1 Hardware Start

A single interface pin (CONV_H) is used for conversion-start control by the host. A conversion cycle is started by a hardware signal when CONV_H is transitioned low-to-high by the host. The host should hold this state until the conversion cycle is complete to avoid erroneous edges causing a conversion start when the present conversion is not complete. The signal is simultaneously sent to the higher device in the stack by the assertion of the CONV_N signal. The bq76PL536A automatically sequences through the series of measurements enabled via the ADC_CONTROL register after a convert-start signal is received from either the register bit or the hardware pin.

If the CONV_H pin is not used in the design, this pin must be maintained in a default low state (approximately 0 V) to allow use of the ADC_CONVERT[CONV] bit to trigger ADC conversions. If the CONV pin is kept high, the ADC_CONVERT[CONV] bit does not function, and device current consumption is increased by the signaling current, approximately 900 μ A. If the CONV_H pin is not used by the user's design, the pin may be left floating; the internal current sink to VSS maintains proper bias.

7.3.1.7.1.2 Firmware Start

The CONVERT_CTRL[CONV] bit is also used to initiate a conversion by writing a 1 to the bit, which automatically resets at the end of a conversion cycle. The bit may only be written to 1; the IC always resets the bit to 0. The BROADCAST form of the packet is recommended to start all device conversions simultaneously.

注

Designer Note: The external CONV_H (CONV_S) pin must be held in the de-asserted (=0) state to allow the CONV register bit to initiate conversions. An internal pulldown is provided on the pin to maintain this state.

Feature Description (continued)

7.3.1.7.2 Data Ready

The bq76PL536A signals that data is ready when the last conversion data has been stored to the associated data result register by asserting the DRDY_S pin (DRDY_H if HOST = 0) if the DRDY_N pin is also asserted (Figure 16). DRDY_S (DRDY_H) signals are cleared on the next conversion start.

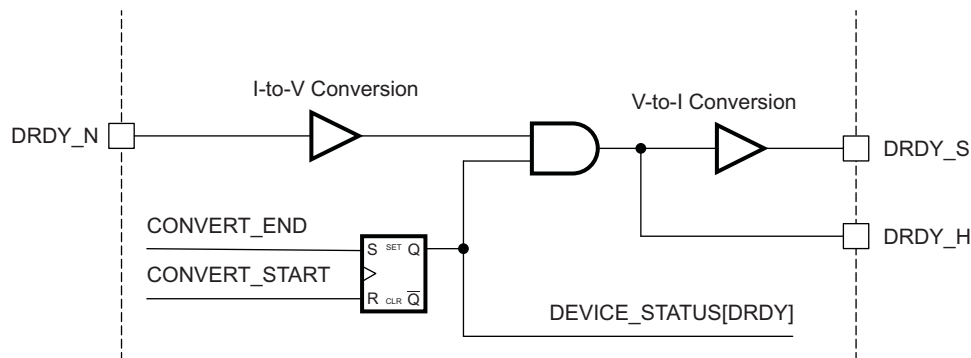

Figure 16. Data-Ready Logic

7.3.1.7.3 ADC Channel Selection

The ADC_CONTROL register can be configured as follows:

Table 1. ADC_CONTROL Register Configuration

MEASUREMENT	ADC_CONTROL
VCELL1	CELL_SEL = 0x00
VCELL1, VCELL2	CELL_SEL = 0x01
VCELL1, VCELL2, VCELL3	CELL_SEL = 0x02
VCELL1, VCELL2, VCELL3, VCELL4	CELL_SEL = 0x03
VCELL1, VCELL2, VCELL3, VCELL4, VCELL5	CELL_SEL = 0x04
VCELL1, VCELL2, VCELL3, VCELL4, VCELL5, VCELL6	CELL_SEL = 0x05
External thermistor input 1	TS1 = 1
External thermistor input 2	TS2 = 1
General-purpose analog input	GPAI = 1

7.3.1.7.4 Conversion Time Control

The ADC conversion time is fixed at approximately 6 μ s per converted channel, plus 6 μ s overhead at the start of the conversion. Total conversion time (μ s) is approximately 6 \times num_channels + 6.

7.3.1.7.5 Automatic Versus Manual Control

The ADC_CONTROL[ADC_ON] bit controls powering up the ADC section and the main bandgap reference. If the bit is set to 1, the internal circuits are powered on, and current consumption by the part increases. Conversions begin immediately on command. The host CPU should wait >500 μ s before initiating the first conversion after setting this bit.

If the ADC_ON bit is false, an additional 500 μ s is required to stabilize the reference before conversions begin.

If the sampling interval (time between conversions) used is less than approximately 10 ms, manual mode should be selected to avoid shifting the voltage reference, leading to inaccuracy in the measurements.

7.3.1.8 Secondary Protection

The bq76PL536A integrates dedicated overvoltage and undervoltage fault detection for each cell and two overtemperature fault detection inputs for each device. The protection circuits use a separate band-gap reference from the ADC system and operate independently. The protector also uses separate I/O pins from the main communications bus, and therefore is capable of signaling faults in hardware without intervention from the host CPU.

7.3.1.8.1 Protector Functionality

When a fault state is detected, the respective fault flag in the FAULT_STATUS or ALERT_STATUS registers is set. All flags in the FAULT and ALERT registers are then ORed into the DEVICE_STATUS FAULT and ALERT bits. The FAULT and ALERT bits in DEVICE_STATUS in turn cause the hardware FAULT_S or ALERT_S pin to be set. The bits in DEVICE_STATUS and the hardware pins are latched until reset by the host via SPI command, ensuring that the host CPU does not miss an event.

A separate timer is provided for each fault source (cell overvoltage, cell undervoltage, overtemperature) to prevent false alarms. Each timer is programmable from 100 μ s to more than 3 s. The timers may also be disabled, which causes fault conditions to be sensed immediately and not latched.

The clearing of the FAULT or ALERT flag (and pin) occurs when the respective flag is written to a 1, which also restarts the respective fault timer. This also clears the FAULT_S ($_H$) or ALERT_S ($_H$) pin. If the actual fault remains present, the FAULT (ALERT) pin is again asserted at the expiration of the timer. This cycle repeats until the cause of the fault is removed.

On exit from the SLEEP state, the COV, CUV, and OT fault comparators are disabled for approximately 200 μ s to allow internal circuitry to stabilize and prevent false error condition detection.

7.3.1.8.1.1 Using the Protector Functions With 3-5 Cells

The OV/UV condition can be ignored for unused channels by setting the FUNCTION_CONFIG[CNx] bits to the maximum number of cells connected to the device. If fewer than 6 cells are configured, the corresponding OV/UV faults are ignored. For example, if the FUNCTION_CONFIG bits are set to xxxx 1000, then the OV/UV comparators are disabled for cells 5 and 6. Correct setting of this register prevents spurious false alarms.

7.3.1.9 Cell Overvoltage Fault Detection (COV)

When the voltage across a cell exceeds the programmed COV threshold for a period of time greater than set in the COV timer (COVT), the COV_FAULT flag for that cell is set (Figure 17). The bits in COV_FAULT are then ORed into the FAULT[COV] flag, which is then ORed into the DEVICE_STATUS[FAULT] flag, which causes the FAULT_S (_H) pin also to be asserted. The COV flag is latched unless COVT is programmed to 0, in which case the flag follows the fault condition. Care should be taken when using this setting to avoid *chatter* of the fault status. To reset the FAULT flag, first remove the source of the fault (for example, the overvoltage condition) and then write a 1 to FAULT[COV], followed by a 0 to FAULT[COV]. See Figure 17 for details.

The voltage trip point is set in the CONFIG_COV register. Set points are spaced every 50 mV. Hysteresis is provided to avoid chatter of the fault sensing. The filter delay time is set in the CONFIG_COVT register to prevent false alarms. A start-up deglitch circuit is applied to the timers to prevent false triggering. The deglitch time is 0–50 μs, and introduces a small error in the timing for short times. For both COVT and CUVT, this can cause an error greater than the 10% maximum specified for delays <500 μs.

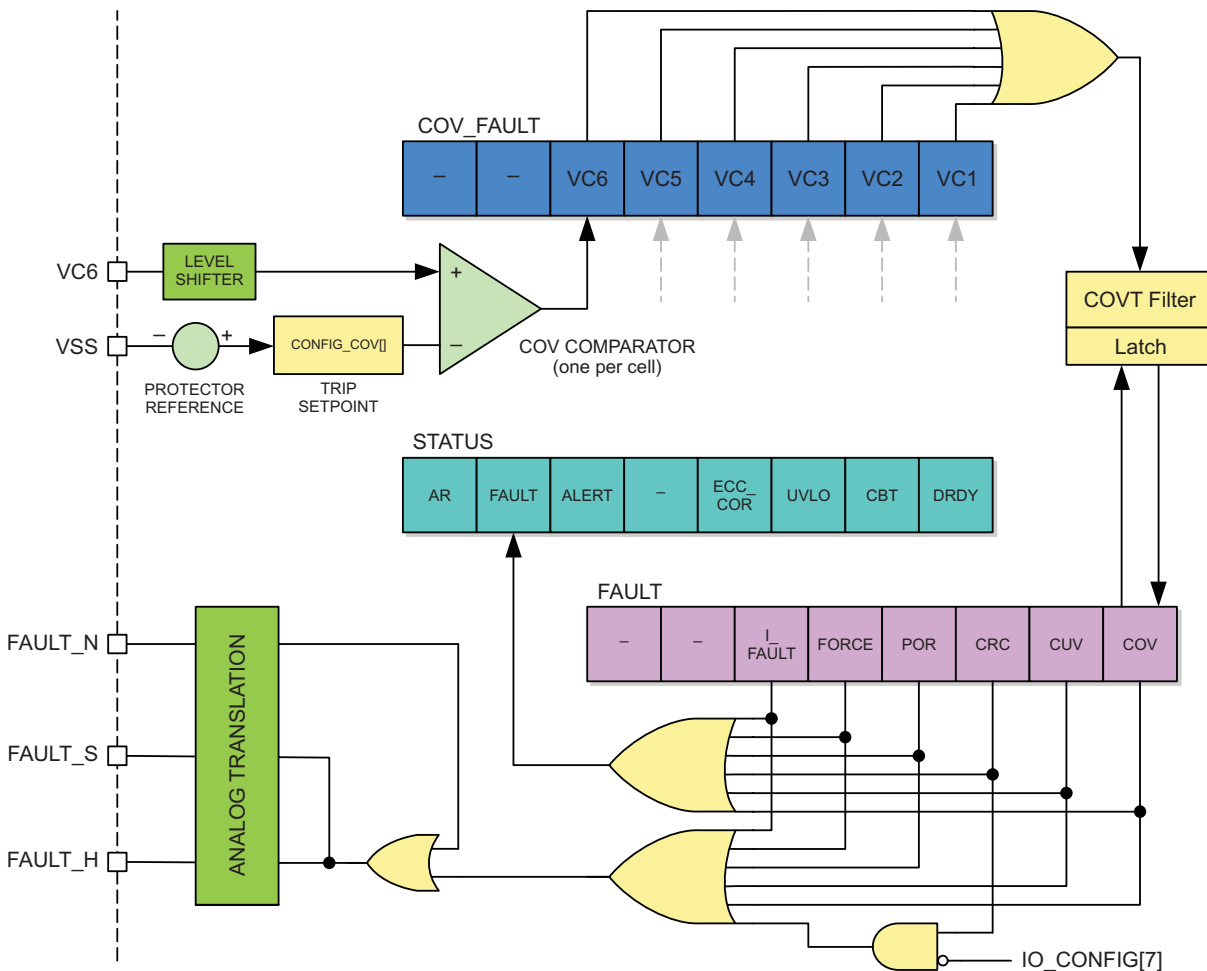

Figure 17. COV FAULT Simplified Logic Tree

7.3.1.10 Cell Undervoltage Fault Detection (CUV)

Cell undervoltage detection operates in a similar manner to the COV protection. When the voltage across a cell falls below the programmed CUV threshold (CONFIG_CUV) for a period of time greater than CUVT (CONFIG_CUVT), the CUV_FAULT flag for that cell is set. The bits in CUV_FAULT are then ORed into the FAULT[CUV] flag, which is then ORed into the DEVICE_STATUS[FAULT] flag, which causes the FAULT_S (_H) pin also to be asserted. The CUV flag is latched unless CUVT is programmed to 0, in which case the flag follows the fault condition. Care should be taken when using this setting to avoid *chatter* of the fault status. To reset the FAULT flag, first remove the source of the fault (for example, the overvoltage condition) and then write a 1 to FAULT[CUV], followed by a 0 to FAULT[CUV].

7.3.1.11 Overtemperature Detection

When the temperature input TS1 or TS2 exceeds the programmed OT1 or OT2 threshold (CONFIG_OT) for a period of time greater than OTT (CONFIG_OTT) the ALERT_STATUS[OT1, OT2] flag is set (Figure 18). The ALERT flags are then ORed into the DEVICE_STATUS[ALERT] flag, and the ALERT_S (_H) pin is also asserted. The OT flag is latched unless OTT is programmed to 0, in which case the flag follows the fault condition. Care should be taken when using this setting to avoid *chatter* of the fault status. To reset the FAULT flag, first remove the source of the alert (for example, the overtemperature condition) and then write a 1 to ALERT[OTn], followed by a 0 to FAULT[OTn].

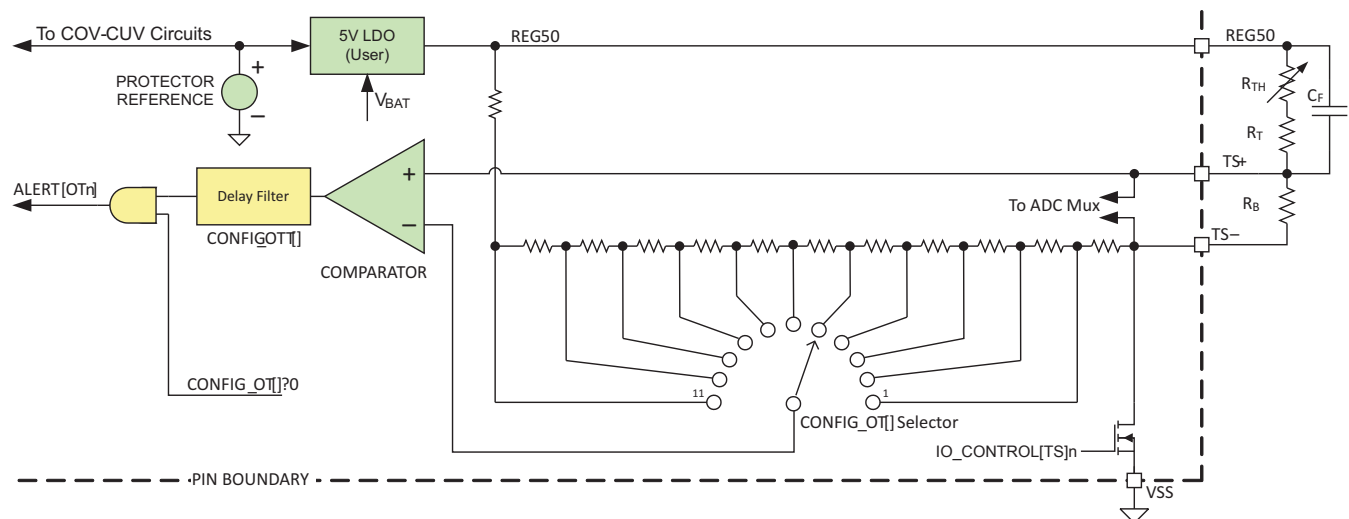

Figure 18. Simplified Overtemperature Detection Schematic

As shown in Figure 18, the OT thresholds are detectable in 11 steps representing approximately 5°C divisions when a thermistor and gain/offset setting resistors are chosen using the formula in the [External Temperature Sensor Support \(TS1+, TS1- and TS2+, TS2-\)](#) section. A *DISABLED* setting is also available. This results in an adjustment range from approximately 40°C to 90°C, but the range center can be moved by modifying the R_T value. The steps are spaced in a non-linear fashion to correspond to typical thermistor response curves. Typical accuracy of a few degrees C or better can be achieved (with no additional calibration requirements) by careful selection of the thermistor and resistors.

Each input sensor can be adjusted independently via separate registers CONFIG_OT1 and CONFIG_OT2. The two temperature set points share a common filter delay set in the CONFIG_OTT register. A setting of 0 in the CONFIG_OTT register causes the fault sensing to be both instantaneous and not latched. All other settings provide a latched ALERT state.

7.3.1.11.1 Ratiometric Sensing

The OT protector circuits use ratiometric inputs to sense fault conditions. The REG50 output is applied internally to the divider which forms the reference voltages used by the comparator circuit. The REG50 output is also used externally as the excitation source for the temperature sensor. This allows the REG50 output to vary over time or temperature (within data-sheet limits) and have virtually no effect on the correct operation of the circuit. Any change seen by the sensor is also seen by the divider, and therefore, changes proportionally. Although it is valid to represent the trip set points as voltages, if you assume that REG50 is at exactly 5 V, in practice, this is not the case. In 表 2, the correct ratios $[R_B/(R_B + R_T + R_{TH})]$ are shown, along with the equivalent voltage points when REG50 is assumed to be 5 V.

表 2. Overtemperature Trip Set Points

OT THRESHOLDS					
CONFIG_OT	T _{NOM} °C ⁽¹⁾	V _{TS} RATIO SET	V _{TS} RATIO CLEAR	V _{SET} ⁽²⁾	V _{CLEAR} ⁽²⁾
0	Disabled	Disabled	Disabled	Disabled	Disabled
1	40	0.2000	0.1766	1.000	0.883
2	45	0.2244	0.2000	1.122	1.000
3	50	0.2488	0.2270	1.244	1.135
4	55	0.2712	0.2498	1.356	1.249
5	60	0.2956	0.2750	1.478	1.375
6	65	0.3156	0.2956	1.578	1.478
7	70	0.3356	0.3162	1.678	1.581
8	75	0.3556	0.3368	1.778	1.684
9	80	0.3712	0.3528	1.856	1.764
10	85	0.3866	0.3688	1.933	1.844
11	90	0.4000	0.3824	2.000	1.912

(1) T_{NOM} depends on thermistor selection

(2) Assumes REG50 = 5.000 V

7.3.1.11.2 Thermistor Power

To minimize power consumption, the thermistors are not powered ON by default. Two bits are provided in IO_CONTROL to control powering the thermistors, TS1 and TS2. The TS_n– input is only connected to VSS when the corresponding bit is set. The user firmware must set these bits to 1 to enable both temperature measurement and the secondary protector functions. When the thermistor functions are not in use, the bits may be programmed to 0 to remove current through the thermistor circuits.

7.3.1.11.3 Thermistor Input Conditioning

A filter capacitor is recommended to minimize noise in to the ADC and protector. The designer should insure that the filter capacitor has sufficient time to charge before reading the thermistors. The CONFIG_OTT value should also be set to >5t, the time delay introduced by the RC network comprising C_F, R_{TH}, R_T, and R_B, to avoid false triggering of the PROTECTOR function and ALERT signal when the TS1 and/or TS2 bits are set to 1 and the inputs enabled.

On exit from the SLEEP state, the OT fault comparators are disabled for approximately 200 μs to allow internal circuitry to stabilize and prevent false error-condition detection.

7.3.1.12 Fault and Alert Behavior

When the FAULT_N pin is asserted by the next higher bq76PL536A in the stack, then the FAULT_S is also asserted, thereby passing the signal down the array of stacked devices if they are present. FAULT_N should always be connected to the FAULT_S of the next higher device in the stack. If no higher device exists, it should be tied to V_{BAT} of this bq76PL536A, either directly or via a pullup resistor from approximately 10 kΩ to 1 MΩ. The FAULT_x pins are active-high and current flows when asserted. The ALERT_x pins behave in a similar manner. If the FAULT_N pin of the base device (HSEL = 0) becomes asserted, it asserts its FAULT_H signal to the host microcontroller. This signal chain may be used to create an interrupt to the CPU, or drive other compatible logic or I/O directly. See 表 3 for further details.

表 3. Fault Detection Summary

FAULT	DETECTION	SIGNALING			
		PIN		DEVICE_STATUS BIT SET	X_STATUS BIT SET
		HSEL = 1	HSEL = 0		
EPROM double bit error	ECC logic fault detected	FAULT_S	FAULT_H	FAULT	FAULT_STATUS[I_FAULT]
FORCE	User set FORCE bit	FAULT_S	FAULT_H	FAULT	FAULT_STATUS[FORCE]
POR	Power-on reset occurred	FAULT_S	FAULT_H	FAULT	FAULT_STATUS[POR]
CRC ⁽¹⁾	CRC fail on received packet	FAULT_S	FAULT_H	FAULT	FAULT_STATUS[CRC]
CUV	$V_{Cx} < V_{UV}$ for t_{UV}	FAULT_S	FAULT_H	FAULT	FAULT_STATUS[CUV]
COV	$V_{Cx} > V_{OV}$ for t_{OV}	FAULT_S	FAULT_H	FAULT	FAULT_STATUS[COV]
AR	Address \neq (0x01 → 0x3e)	ALERT_S	ALERT_H	ALERT	ALERT_STATUS[AR]
Protected-register parity error	Parity not even in protected register	ALERT_S	ALERT_H	ALERT	ALERT_STATUS[PARITY]
EPROM single-bit error	ECC logic fault detected and corrected	ALERT_S	ALERT_H	ALERT	ALERT_STATUS[ECC_COR]
FORCE	User set FORCE bit	ALERT_S	ALERT_H	ALERT	ALERT_STATUS[FORCE]
Thermal shutdown	Die temperature \geq TSD _{THRESHOLD}	ALERT_S	ALERT_H	ALERT	ALERT_STATUS[TSR]
SLEEP	IC exited SLEEP mode	ALERT_S	ALERT_H	ALERT	ALERT_STATUS[SLEEP]
OT2	$V_{TS2} > V_{OT}$ for t_{OT}	ALERT_S	ALERT_H	ALERT	ALERT_STATUS[OT2]
OT1	$V_{TS1} > V_{OT}$ for t_{OT}	ALERT_S	ALERT_H	ALERT	ALERT_STATUS[OT1]

(1) The CRC fault may be prevented from setting the FAULT pin by setting IO_CONFIG[7] = 1. The FAULT_STATUS[CRC] bit is still set when CRC error is detected, but the FAULT pin remains de-asserted.

7.3.1.12.1 Fault Recovery Procedure

When any error flag in DEVICE_STATUS, FAULT_STATUS, or ALERT_STATUS is set and latched, the state can only be cleared by host communication via SPI. Writing to the respective FAULT_STATUS or ALERT_STATUS register bit with a 1 clears the latch for that bit. The exceptions are the two FORCE bits, which are cleared by writing a 0 to the bit.

The FAULT_STATUS and ALERT_STATUS register bits are read-only, with the exception of the FORCE bit, which may be directly written to either a 1 or 0.

7.3.1.13 Secondary Protector Built-In Self-Test Features

The secondary protector functions have built-in test for verifying the connections through the signal chain of ICs in the stack back to the host CPU. This verifies the wiring, connections, and signal path through the ICs by forcing a current through the signal path.

To implement this feature, host firmware should set the FAULT[FORCE] or ALERT[FORCE] bit in the top-most device in the stack. The device asserts the associated pin on the South interface, and it propagates down the stack, back to the base device. The base device in turn asserts the FAULT_H (ALERT_H) pin to the host, allowing the host to check for the received signal and thereby verify correct operation.

7.3.2 Cell Balancing

The bq76PL536A has six dedicated outputs (CB1...CB6) that can be used to control external N-FETs as part of a cell balancing system. The implementation of appropriate algorithms is controlled by the system host. The CB_CTRL[CBAL1–6] bits control the state of each of the outputs. The outputs are copied from the bit state of the CB_CTRL register, that is, a 1 in this register activates the external balance FET by placing a high on the associated pin.

The CBx pins switch between approximately the positive and negative voltages of the cell across which the external FET is connected. This allows the use of a small, low-cost N-FET in series with a power resistor to provide cell balancing.

7.3.2.1 Cell Balance Control Safety Timer

The CBx outputs are cleared when the internal safety timer expires. The internal safety timer (CB_TIME) value is programmed in units of seconds or minutes (range set by CB_CTRL bit 7) with an accuracy of $\pm 10\%$.

The timer begins when any CB_CTRL bit changes from 0 to 1. The timer is reset if all CB_CTRL bits are modified by the host from 1 to 0, or by expiration of the timing period. The timing begins counting the programmed period from start **each time** the CB_CTRL register is programmed from a zero to a non-zero value in the lower six bits. In the example, if the CB_TIME is set for 30 s, then one or more bits are set in the CB_CTRL register to balance the corresponding cells; then after 10 s the user firmware sets CB_CTRL to 0x00, takes a measurement and then reprograms CB_CTRL with the same or new bit pattern and the timer begins counting 30 s again before expiring and disabling balancing. This restart occurs each time the CB_CTRL bits are set to a non-zero value. If this is done at a greater rate than the balancing period for which timer CB_TIME is set, balancing is effectively never disabled – until the timer is either allowed to expire without changing the CB_CTRL register to a non-zero value, or the CB_CTRL register is set to zero by the user firmware. If the CB_CTRL register is not manipulated from zero to non-zero while the timer is running, the timer expires as expected. Alterations of the value from a non-zero to a different non-zero value *do not* restart the timer (such as, from 0x02 to 0x03, and so forth).

While the timer is running, the host may set or reset any bit in the CB_CTRL register at any time, and the CBx output follows the bit.

The host may re-program the timer at any time. The timer must always be programmed to allow the CBx outputs to be asserted. While the timer is non-zero, the CB_CTRL settings are reflected at the outputs.

During periods when the timer is actively running (not expired), then DEVICE_STATUS[CBT] is set.

7.3.3 Other Features and Functions

7.3.3.1 Internal Voltage Regulators

The bq76PL536A derives power from the BAT pin using several internal low dropout (LDO) voltage regulators. There are separate LDOs for internal analog circuits (5 V at LDOA), digital circuits (5 V at LDOD1 and LDOD2), and external, user circuits (5 V at REG50). The BAT pin should be connected to the most-positive cell input from cell 3, 4, 5, or 6, depending on the number of cells connected. Locate filter capacitors as close to the IC as possible. The internal LDOs and internal V_{REF} should not be used to power external circuitry, with the exception that LDODx should be used to source power to any external pullup resistors.

7.3.3.1.1 Internal 5-V Analog Supply

The internal analog supply should be bypassed at the LDOA pin with a good-quality, low-ESR, 2.2- μ F ceramic capacitor.

7.3.3.1.2 Internal 5-V Digital Supply

The internal digital supply should be bypassed at the LDOD1(2) pin with a good-quality, low-ESR, 2.2- μ F ceramic capacitor. The two pins are connected internally and provided to enhance single-pin failure-mode fault tolerance. They should also be connected together externally.

注

Designer Note: Because the LDODx inputs are pulled briefly to approximately 7 V during programming, the LDODx pins should not be used as sources for pullups to 5-V digital pins, such as HSEL and SPI(bus)_H connected pins. Use VREG50 instead, unless all programming is completed prior to mounting on the application PCB, in which case LDODx is a good choice.

7.3.3.1.3 Low-Dropout Regulator (REG50)

The bq76PL536A has a low-dropout (LDO) regulator provided to power the thermistors and other external circuitry. The input for this regulator is V_{BAT} . The output of REG50 is typically 5 V. A minimum 2.2- μ F capacitor is required for stable operation. The output is internally current-limited. The output is reduced to near zero if excess current is drawn, causing die temperatures to rise to unacceptable levels.

The 2.2- μ F output capacitor is required whether REG50 is used in the design or not.

REG50 is disabled in SLEEP mode, and may be turned off under thermal-shutdown conditions, and therefore should not be used as a pullup source for terminating device pins where required.

7.3.3.1.4 Auxiliary Power Output (AUX)

The bq76PL536A provides an approximately 1-mA auxiliary power output that is controlled through IO_CONTROL[AUX]. This output is taken directly from REG50. The current drawn from this pin must be included in the REG50 current-limit budget by the designer.

7.3.3.2 Undervoltage Lockout and Power-On Reset

The device incorporates two comparators to detect low V_{BAT} conditions. The first detects low voltage where some device digital operations are still available. The second, (POR) detects a voltage below which device operation is **not** ensured.

7.3.3.2.1 UVLO

When the UVLO threshold voltage is sensed for a period $\geq UVLO_{DELAY}$, the device is no longer able to make accurate analog measurements and conversions. The ADC, cell-balancing and fault-detection circuitry are disabled. The digital circuitry, including host CPU and vertical communications between ICs, is fully functional. Register contents are preserved with the exception that CB_CTRL is set to 0, and the UVLO bit is set in DEVICE_STATUS.

7.3.3.2.2 Power-On Reset (POR)

When the POR voltage threshold or lower is sensed for a period $\geq UVLO_{DELAY}$, the device is no longer able to function reliably. The device is disabled, including all fault-detection circuitry, host SPI communications, vertical communications, and so forth.

After the voltage rises above the hysteresis limit longer than the delay time, the device exits the reset state, with all registers set to default conditions. The FAULT_STATUS[POR] bit is set and latched until reset by the host. The device no longer has a valid address (DEVICE_ADDRESS[AR] = 0, ADDRESS_CONTROL = 0). The device should be reprogrammed with a valid address, and any registers re-written if non-default values are desired.

7.3.3.2.3 Reset Command

The bq76PL536A can also be reset by writing the reset code (0xa5) to the RESET register. All devices respond to a broadcast RESET command regardless of their current assigned address. The result is identical to a POR with the exception that the normal POR period is reduced to several hundred microseconds.

7.3.3.3 Thermal Shutdown (TSD)

The bq76PL536A contains an integrated thermal shutdown circuit whose sensor is located near the REG50 LDO and has a threshold of T_{SD} . When triggered, the REG50 regulator reduces its output voltage to zero, and the ADC is turned off to conserve power. The thermal shutdown circuit has a built-in hysteresis that delays recovery until the die has cooled slightly. When the thermal shutdown is active, the DEVICE_STATUS[TSD] bit is set. The IO_CONTROL[SLEEP] and ALERT[SLEEP] bits also become set to reduce power consumption.

注意

In the TSD state, the following are DISABLED:

- REG50 and AUX outputs
- Secondary protector settings

Due to the loss of REG50 and AUX outputs, any measurements (for example, voltage on a thermistor biased by either) should be considered incorrect.

Any external protection schemes depending on either of these voltages will also be impacted and the system designer shall make the appropriate decisions based on this.

7.3.3.4 GPIO

The bq76PL536A includes a general-purpose input/output pin controlled by the IO_CONTROL[GPIO_OUT] bit. The state of this bit is reflected on the pin. To use the pin as an input, program GPIO_OUT to a 1, and then read the IO_CONTROL[GPIO_IN] bit. A pullup (10 kΩ–1 MΩ, typ.) is required on this pin if used as an input. *If the pullup is not included in the design, system firmware must program a 0 in IO_CONTROL[GPIO_OUT] to prevent excess current draw from the floating input. Use of a pullup is recommended in all designs to prevent an unintentional increase in current draw.*

7.3.4 Communications

7.3.4.1 SPI Communications – Device to Host

Device-to-host (D2H) mode is provided on the SPI interface pins for connection to a local host microcontroller, logic, and so forth. D2H communications operate in voltage mode as a standard SPI interface for ease of connection to the outside world from the bq76PL536A device. Standard TTL-compatible logic levels are presented. All relevant SPI timing and performance parameters are met by this interface.

The host interface operates in SPI mode 1, where CPOL = 0 and CPHA = 1. The SPI clock is normally low; data changes on rising edges, and is sampled on the falling edge. All transfers are MSB-first.

The pins of the base IC (only) in a stack should have the SCLK_H and SDI_H pins terminated with pullups to minimize current draw of the part if the host ever enters a state where the pins are not driven, that is, held in the high-impedance state by the host. In non-base devices, the _H pins are forced to be all outputs driven low when the HSEL pin is high. In non-base devices, all _H pins should remain unconnected.

The CS_H has a pullup resistor of approximately 100 kΩ. SDO_H is a 3-state output and is terminated with a weak pullup.

注

Designer Note: When V_{BAT} is at or below the UVLO trip point voltage, the internal LDO which supplies the xxx_H host SPI communications pins (VLODx) begins to fall out of regulation. The output high voltage on the xxx_H pins falls off with the LDO voltage in an approximately linear manner until at the POR voltage trip point where it is reduced to approximately 3.5 V. This action is not tested in production.

7.3.5 Device-to-Device Vertical Bus (VBUS) Interface

Device-to-device (D2D) communications makes use of a unique, current-mode interface which provides common-mode voltage isolation between successive bq76PL536As. This *vertical bus* (VBUS) is found on the _N and corresponding _S pins. It provides high-speed I/O for both the SPI bus and the direct I/O pins CONV and DRDY. The current-mode interface minimizes the effects of wiring capacitance on the interface speed.

The _S (south-facing) pins connect to the next-lower device (operating at a lower potential) in the stack of bq76PL536As. The _N (North facing) pins connect to the next-higher device. The pins cannot be swapped; _S always points South, and _N always point North. The _S and _N pins are interconnected to the pin with the same name, but opposite suffix. All pins operate within the voltages present at the BAT and VSS pins.

警告

These pins may be several hundred volts above system ground, depending on their position in the stack.

注

Designer Note: North (_N) pins of the top, most-positive device in the stack should be connected to the BAT1(2) pins of the device for correct operation of the string. South (_S) pins of the lowest, most-negative device in the stack should be connected to VSS of the device.

The number of devices in the vertical stack and other factors limit the maximum SCLK frequency. Each device imposes an approximately 30-ns delay on the round trip communications speed, that is, from SCLK rising (an input to all devices) to the SDO pin transitioning requires approximately 30 ns per device. The designer must add to this the delay caused by the PCB trace (in turn determined by the material and layout), any connectors in series with the connection, and any other wiring or cabling between devices in the system. To maximize speed, these other system components should be carefully selected to minimize delays and other detrimental effects on signal quality. Wiring and connectors should receive special attention to their transmission line characteristics.

Other factors which should be considered are clock duty cycle, clock jitter, temperature effects on clock and system components, user-selected drive level for the level-shift interface, and desired design margin.

The VBUS SPI interface is placed in a low-power mode when CS_H is not asserted on the base device.

The CS_N/S pins are asserted by a logic high on the vertical interface bus (logically inverted from CS_H). This creates a default VBUS CS condition of logic low, reducing current consumption to a minimum.

To reduce power consumption of the SPI interface to a minimum, the SCLK_H and SDI_H should be maintained at a logic low (de-asserted) while CS_H is asserted (low). Most SPI buses are operated this way by microcontrollers. The VBUS versions of these signals are not inverted from the host interface. The device also de-asserts by default the SDO_N/S pins to minimize power consumption.

7.3.6 Packet Formats

7.3.6.1 Data Read Packet

When the bq76PL536A is selected (CS_S [CS_H for first device] is active and the bq76PL536A has been addressed) and read request has been initiated, then the data is transmitted on the SDO_S pin to the SDO_N pin of the next device down the stack. This continues to the first device in the stack, where the data in from the SDO_N pin is transmitted to the host via the SDO_H pin. The device supplying the read data generates a CRC as the last byte sent. See [Fig 19](#) and [Fig 20](#) for additional information.

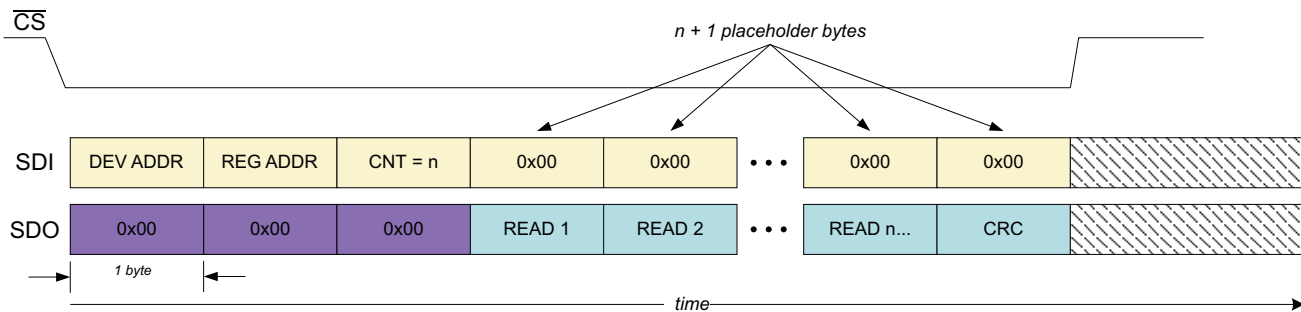

Fig 19. READ Packet Format

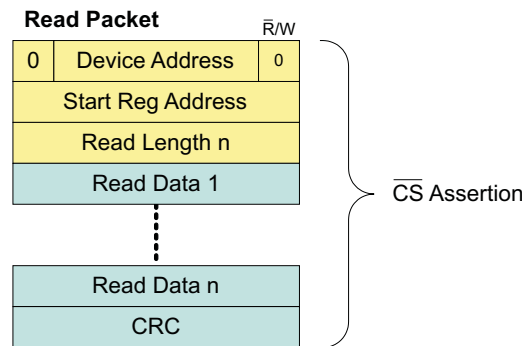

Fig 20. READ Packet Detail

7.3.6.2 Data Write Packet

When the bq76PL536A is selected (CS_S is active and the bq76PL536A has been addressed) and a write request has been initiated, the bq76PL536A receives data through the SDI_S pin, which is connected to the SDO_N of the lower device. For the first device in the stack, the data is input to the SDI_H pin from the host, and transmitted up the stack on the SDI_S pin to the SDI_N pin of the next higher device. If enabled, the device checks the CRC, which it expects as the last byte sent. If the CRC is valid, no action is taken. If the CRC is invalid or missing, the device asserts the ALERT_S signal to the next lower device, which ripples down the stack to the ALERT_H pin on the lowest device. The host should then take action to clear the condition. See [Figure 21](#) and [Figure 22](#) for details.

Unused or undefined register bits should be written as zeros.

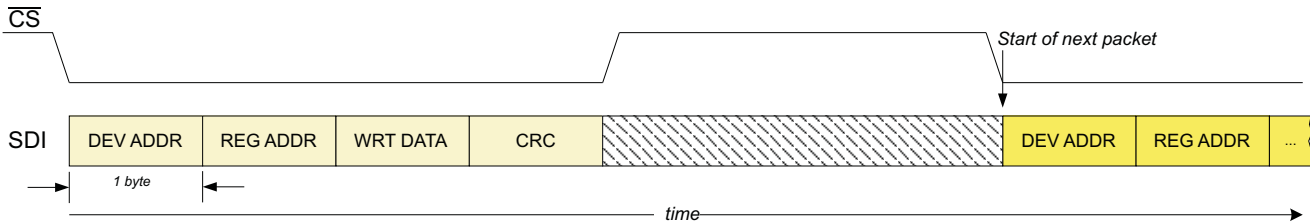

Figure 21. WRITE Packet Format

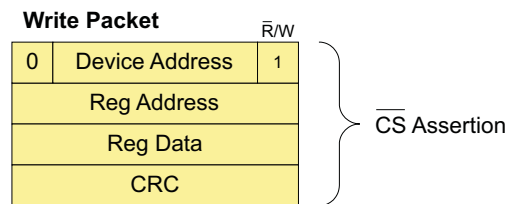

Figure 22. WRITE Packet Detail

7.3.6.3 Broadcast Writes

The bq76PL536A supports broadcasting single register writes to all devices. A write to device address 0x3f is recognized by all devices on the bus with a valid address, and permits efficient simultaneous configuration of all registers in the stack of devices. This also permits synchronizing all ADC conversions by a firmware command sent to the CONVERT_CTRL register as an alternative to using the CONV and DRDY pins.

7.3.6.4 Communications Packet Structure

The bq76PL536A has two primary communication modes through the SPI interface. These two modes enable single-byte read / write and multiple data reads. All writes are single-byte; the logical address is shifted one bit left, and the LSB = 1 for writing.

All transactions are in the form of packets comprising:

表 4. Communication Packet Order

BYTE	DESCRIPTION
#1	6-bit bq76PL536A slave address + R/W bit 0b0xxx xxxW
#2	Starting data-register offset
#3	Number of data bytes to be read (n) (omitted for writes)
#4 to 3+n	Data bytes
#4+n	CRC (omit if IO_CONFIG[CRC_DIS] = 1)

7.3.6.5 CRC Algorithm

The cyclic redundancy check (CRC) is a CRC-8 error-checking byte, calculated on all the message bytes (including addresses). It is identical in structure to the SMBus 2.0 packet error check (PEC), and is also known as the ATM-8 CRC. The CRC is appended to the message for all SPI packets by the device that supplied the data as the last byte in the packet (when `IO_CONTROL[CRC] == 1`).

Each bus transaction requires a CRC calculation by both the transmitter and receiver within each packet. The CRC is calculated in a way that conforms to the polynomial, $C(x) = x^8 + x^2 + x^1 + 1$ and must be calculated in the order of the bits as received, MSB first. The CRC calculation includes all bytes in the transmission, including address, command, and data. When reading data from the device, the CRC is based on the `ADDRESS + FIRST_REGISTER + LENGTH + returned_device_data[n]`. The stuff-bytes used to clock out the data from the IC are not used as part of the calculation, although if the value 0x00 is used, the 0s have no effect on the CRC.

CRC verification is performed by the receiver when the `CS_x` line goes false, indicating the end of a packet. If the CRC verification fails, the message is ignored (discarded), the CRC failure flag is set in the `FAULT_STATUS[CRC]` register, and the `FAULT` line becomes asserted and latched until the error is read and cleared by the host.

The CRC bit returned in the `FAULT_STATUS` register reflects the last packet received, not the CRC condition of the packet reading the `FAULT_STATUS` contents. CRC errors should be handled at a high priority by the host controller, before writing to additional registers.

7.3.6.6 Data Packet Usage Examples

The bq76PL536A can be enabled via the host to read just the specific voltage data which would require a total of 2 written bytes (chip address and R/W [#1] + first (starting) register offset [#2]) + `LENGTH` [#3] and 13 <null> stuff bytes (12 [n] data bytes + CRC).

The data packet can be expanded periodically to accommodate temperature and GPAl readings as well as device status as needed by changing the `REGISTER_FIRST` offset and `LENGTH` values.

7.3.7 Device Addressing

Each individual device in the series stack requires an address to allow communication with it. Each bq76PL536A has a `CS_S` and `CS_N` that are used in assigning addresses. Once addresses have been assigned, the normal operation of the `CS_N/S` lines is asserted (logic high) during communications, and the appropriate bq76PL536A in the stack responds according to the address transmitted as part of the packet ([Figure 23](#)).

When the bq76PL536A is reset, the `DEVICE_STATUS[AR]` (address request) flag is cleared, the address register is set to 0x00, and `ALERT_S` is set and passed down the stack. In this state, where address = 0x00, the `CS_N` signal is forced to a de-asserted state (`CS` is not passed north when an address = 0). In this manner, after a reset the host is assured that a response at address 0x00 is from the first physical device in the stack. After address assignment of the current device, the host is assured that the next response at address 0x00 is from the next physical device in the stack.

Once a valid address is assigned to the device, the `CS_N` signal responds normally, and follows the `CS_H` or `CS_S` signal, propagating to the next device in the stack. Valid addresses are in the range 0x01 through 0x3e. 0x00 is reserved for device discovery after reset. 0x3f is reserved as a broadcast address for all devices.

注

Designer Note: Broadcast messages are only received by devices with a valid address, and the next higher device. Any device with an address of 0x00 blocks messages to devices above it. A broadcast message may not be received by all devices in a stack in situations where some devices do not have a valid address.

All devices:
ADDRESS = 0x?? (unknown)
expected = # devices in stack

Note: validated = one more than
devices found at this point

Assign unique address (n) to
this device @address 0x00

Validation test: Read same
device for unique address (n)
just assigned

Validate device was
successfully found and
addressed

This loop finds one *new*
device per iteration

(Implied: $n == look_for$ here)

This loop resets all addressed
devices, then looks for all
previously found+1 devices
again. Corrects any
addressing faults in the stack

(Implied: $n == expected$ here)

All devices found?

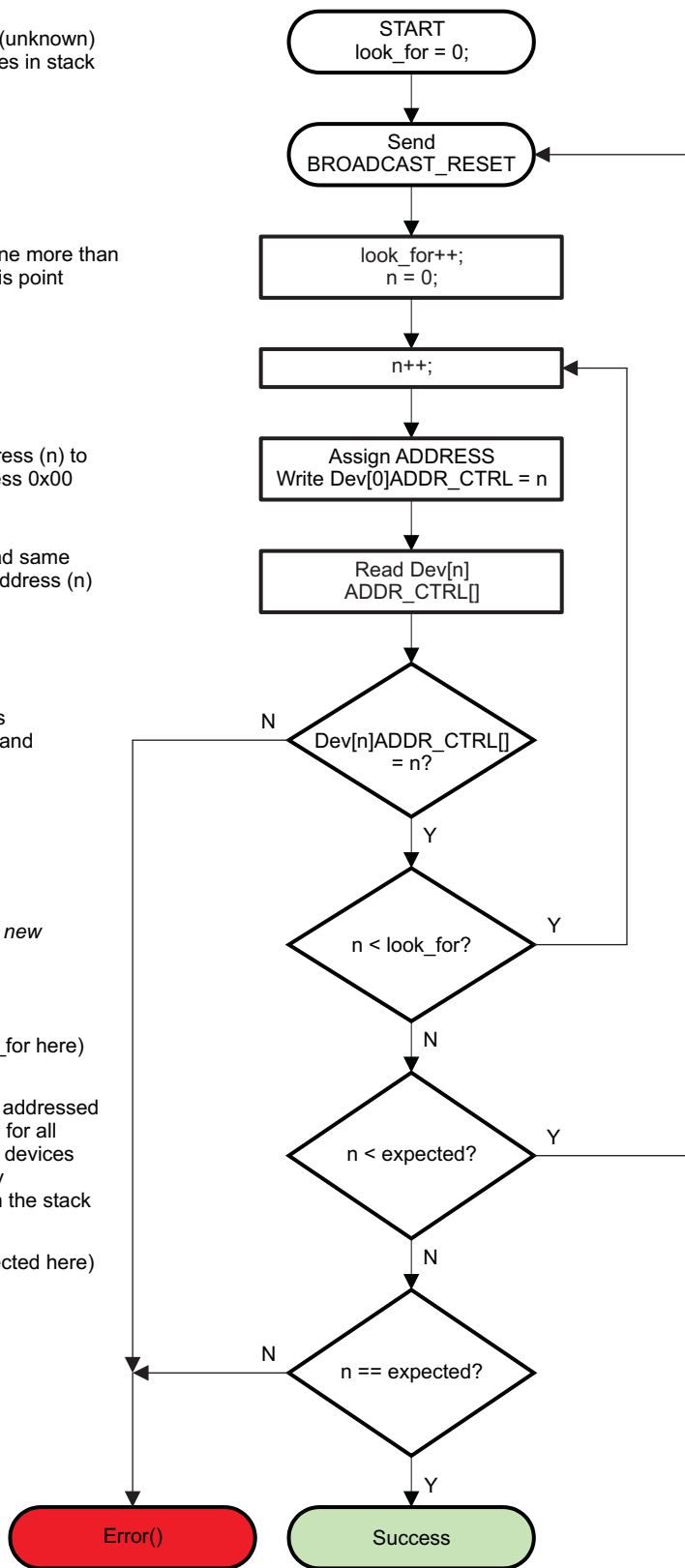

23. Address Discovery and Assignment Algorithm

Once the address is written, the ADDRESS_CONTROL[AR] bit is set which is copied to the DEVICE_STATUS[AR] and also ALERT_S if ALERT_N is also de-asserted. This allows the CS_N pin to follow (asserted) the CS_S pin assertions. The process of addressing can now be repeated as device 'n' has a new address and device n+1 has the default address of 0x00, and can be changed to its *correct* address in the stack.

If a device loses its address through a POR or it is replaced then this device will be the highest logical device in the stack able to be addressed (0x00) as its CS_N will be disabled and the addressing process is required for this and higher devices.

7.3.8 Changes and Enhancements for bq76PL536A

- Improved power management during CRC faults – Configuration bit IO_CONFIG[CRCNOFLT] (bit7) was added to disable CRC fault from asserting the FAULT pin. This feature is useful under very low-power operating conditions.
- ADC accuracy improvements – The conversion timing is now fixed at 6 μ s, offering improved accuracy over the original bq76PL536.
- Improved ADC automatic mode functionality, allowing optimized and fully automatic internal power management (ADC_CTRL[ADC_ON] = 0) during normal operation at sample rates (time between conversions) > 10 ms.
- Pin DRDY logic now indicates conversion status of all devices in the system.
- Improved V_{BUS} communications reduce noise, enhance drive levels and hysteresis to improve battery stack communications, and eliminate eight external components or more. Support for longer distances between ICs and/or higher speeds for implementing large battery stack sizes.
- Improved flowchart for device addressing provided in data sheet.

7.4 Device Functional Modes

7.4.1 SLEEP Functionality

The bq76PL536A provides the host a mechanism to put the part into a low-power sleep state by setting the IO_CONTROL[SLEEP] bit. When this bit is set/reset, the following actions occur as stated in the following paragraphs.

7.4.1.1 SLEEP State Entry (Bit Set)

If a conversion is in progress, the device waits for it to complete, then sets DRDY true (high).

The device sets the ALERT_STATUS[SLEEP] bit, which in turn causes the ALERT pin to be asserted.

The device gates off all other sources of FAULT or ALERT *except* ALERT[SLEEP]. The existing state of the FAULT and ALERT registers is preserved. The host should service and reset the ALERT generated by the SLEEP bit being set to minimize SLEEP state current draw by writing a 1 to ALERT[SLEEP] followed by a 0 to ALERT[SLEEP]. The ALERT North-South signal chain can draw up to approximately 1 mA of current when active, so this ALERT source should be cleared prior to the host entering the SLEEP state of its own. This signaling is provided to notify the host that the unmonitored/unprotected state is being entered.

The REG50 LDO is shut down and the output is allowed to float. The ADC, its reference, and clocks are disabled. The COV, CUV, and OT circuits are disabled, and their band-gap reference shut off.

注意

The SLEEP State effectively removes protection and monitoring from the cells; the designer should take the necessary design steps and verifications to ensure the cells cannot be put into an unsafe condition by other parts of the system or usage characteristics.

Device Functional Modes (continued)

IO_CONTROL[TS1:TS2] bits are not modified. The host must also set these bits to zero to minimize current draw of the thermistors themselves.

SPI communications are preserved; all registers may be read or written.

7.4.1.2 Sleep State Exit (Bit Reset)

VREG50 operation is restored.

COV, CUV, OT circuits are re-enabled.

The ADC circuitry returns to its former state. Note that there is a warm-up delay associated with the ADC enable, the same delay as specified for enabling from a cold start.

The FAULT and ALERT registers are restored to their pre-SLEEP state. If a FAULT or ALERT condition was present prior to SLEEP, the FAULT or ALERT pin is immediately asserted.

IC_CONTROL[TS1:TS2] should be set by the host if the OT function or temperature measurement functions are desired.

7.5 Programming

7.5.1 Programming the EPROM Configuration Registers

The bq76PL536A has a block of OTP-EPROM that is used for configuring the operation of the bq76PL536A. Programming of the EPROM should take place during pack/system manufacturing. A 7-V (V_{PP}) pulse is required on the PROG pin. The part uses an internal window comparator to check the voltage, and times the internal pulse delivered to the EPROM array.

The user first writes the desired values to all of the equivalent Group3 protected register addresses. The desired data is written to the appropriate address by first applying 7 V to the LDOD1(2) pins. Programming then performed by writing to the EE_EN register (address 0x3f) with data 0x91. After a time period > 1500 μ s, the 7 V is removed. Nominally, the voltage pulse should be applied for approximately 2–3 ms. Applying the voltage for an extended period of time may lead to device damage. The write is self-timed internally after receipt of the command. The following flow chart ([Figure 24](#)) illustrates the procedure for programming.

Programming (continued)



图 24. EPROM Programming

7.6 Register Maps

7.6.1 I/O Register Details

The bq76PL536A has 48 addressable I/O registers. These registers provide status, control, and configuration information for the battery protection system. Reserved registers return 0x00. Unused registers should not be written to; the results are undefined. Unused or undefined bits should be written as zeroes, and will always read back as zeroes. Several types of registers are provided, details are in the following sections and tables.

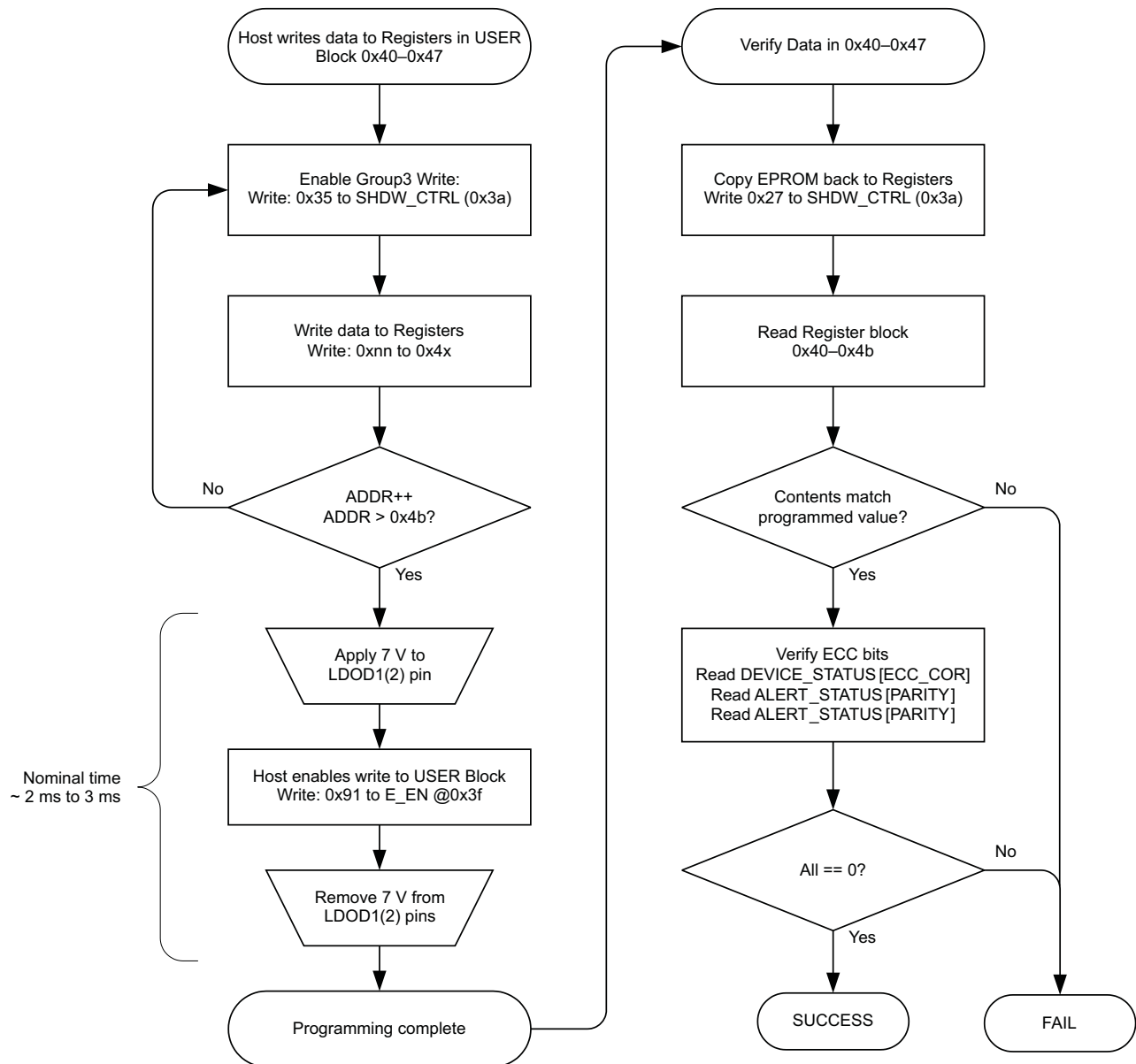
7.6.2 Register Types

7.6.2.1 Read-Only (Group 1)

These registers contain the results of conversions, or device status information set by internal logic. The contents are re-initialized by a device reset as a result of either POR or the RESET command. Contents of the register are changed by either a conversion command, or when there is an internal state change (that is, a fault condition is sensed).

7.6.2.2 Read / Write (Group 2)

The Read/Write register group modifies the operations or behavior of the device, or indicates detailed status in the ALERT_STATUS and FAULT_STATUS registers (Figure 25). The contents are re-initialized by a device reset as a result of either POR or the RESET command. Contents of the register are changed either by a conversion command, or when there is an internal state change (that is, a fault condition is sensed).

Contents may also be changed by a write from the host CPU to the register. Writes may only modify a single register at a time. If CRCs are enabled, the write packet is buffered until the CRC is checked for correctness. Packets with bad CRCs are discarded without writing the value to the register, after setting the FAULT_STATUS[CRC] flag.

Unused or undefined bits in any register should be written as zeros, and will always read back as zeros.

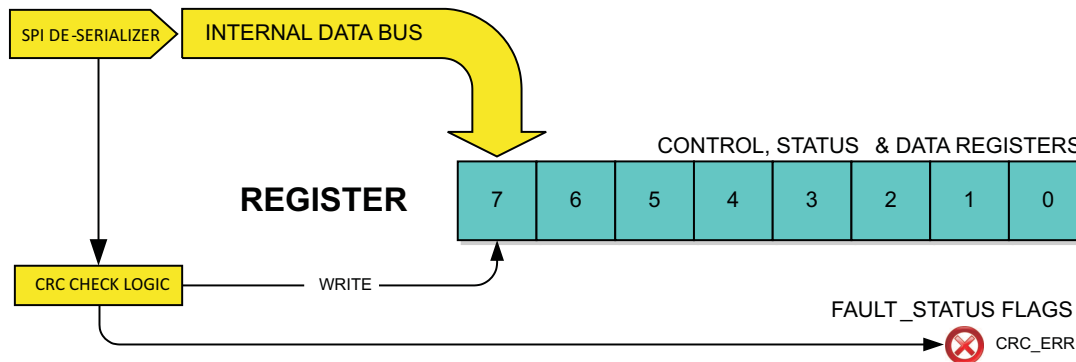

Figure 25. Register Group2 Architecture

7.6.2.3 Read / Write, Initialized From EPROM (Group3)

These registers control the device configuration and functionality. The contents of the registers are initialized from EPROM-stored constants as a result of POR, RESET command, or the RELOAD_SHADOW command. This feature ensures that the secondary protector portion of the device (COV, CUV, OT) is fully functional after any reset, without host CPU involvement. See Figure 26 for a simplified view.

These registers may only be modified by using a special, sequential-write sequence to guard against accidental changes. The value loaded from EPROM at reset (or by command) may be temporarily overwritten by using the special write sequence. The temporary value is overwritten to the programmed EPROM initialization value by the next reset or command to reload. To write to a these protected registers, first write 0x35 to SHDW_CONTROL, immediately followed by the write to the desired register. Any intervening write cancels the special sequence.

To re-initialize the entire set of Group3 registers to the EPROM defaults, write the value 0x27 to SHDW_CONTROL.

Register Maps (continued)

These registers are protected further against corruption by a ninth parity bit that is automatically updated when the register is written using even parity. If the contents of the register ever become corrupted, the bad parity causes the ALERT_STATUS[PARITY] bit to become set, alerting the host CPU of the problem.

The EPROM-stored constants are programmed by writing the values to the register(s), then applying the programming voltage to the LDODx pins, then issuing the EPROM_WRITE command to register E_EN. All Group3 registers are programmed simultaneously, and this operation can only be performed once to the one-time-programmable (OTP) memory cells. The process is not reversible.

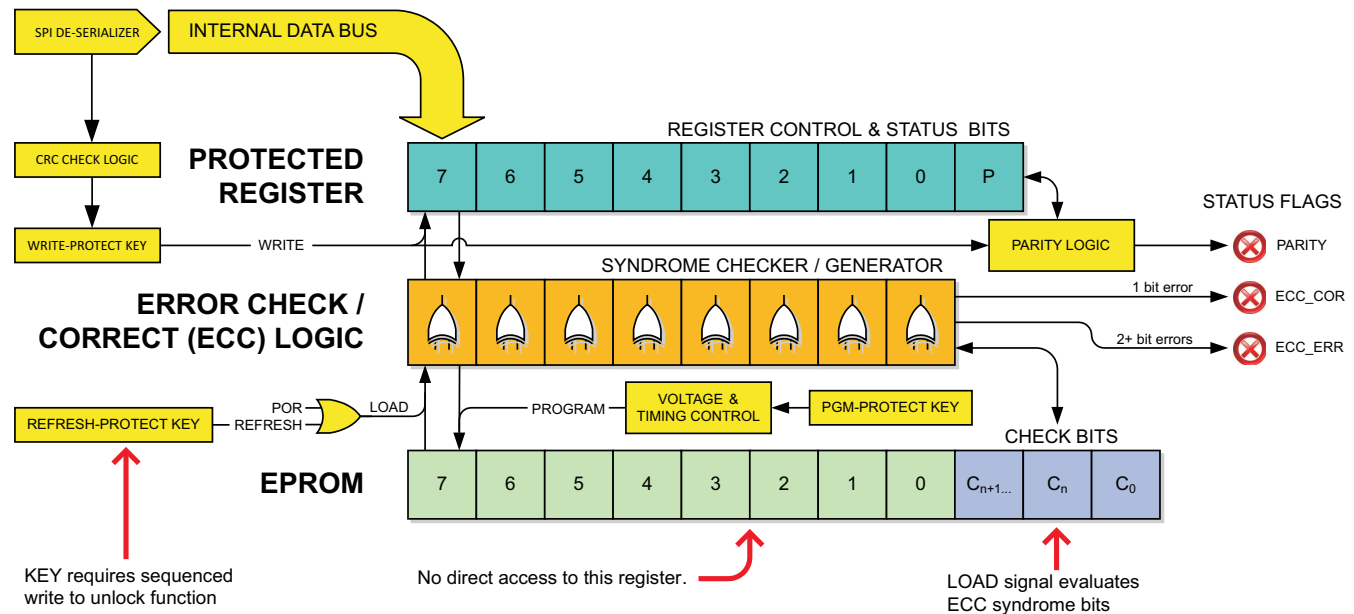

26. Protected Register Group3 Architecture, Simplified View

7.6.2.4 Error Checking and Correcting (ECC) EPROM

The EPROM used to initialize this group is also protected by error-check-and-correct (ECC) logic. The ECC bits provide a highly reliable storage solution in the presence of external disturbances. This feature cannot be disabled by user action. Implementation is fully self-contained and automatic and requires no special computations or provisioning by the user.

When the Group3 contents are permanently written to EPROM, an additional array of hidden ECC-OTP cells is also automatically programmed. The ECC logic implements a Hamming code that automatically corrects all single-bit errors in the EPROM array, and senses additional multi-bit errors. If any corrections are made, the DEVICE_STATUS[ECC_COR] flag bit is set. If any multi-bit errors are sensed, the ALERT_STATUS[ECC_ERR] flag is set. The corrective action or detection is performed anytime the contents of EPROM are loaded into the registers – POR, RESET, or by REFRESH command. *Note: The ECC_COR and ECC_ERR bits may glitch during OTP-EPROM writes; this is normal. If this occurs, reset the tripped bit; it should remain cleared.*

When a double-bit (uncorrectable) error is found, DEVICE_STATUS[ALERT] is set, the ALERT_S (ALERT_H for bottom stack device) line is activated, and the ALERT_STATUS register returns the ECC_ERR and/or I_FAULT bit = 1(true). *The device may return erroneous measurement data, and/or fail to detect COV, CUV, or OT faults in this state.*

EPROM bits are shipped from the factory set to 0, and must be programmed to the 1 state as required.

Register Maps (continued)
表 5. Data and Control Register Descriptions

NAME	ADDR	GROUP	ACCESS ⁽¹⁾	RESET	DESCRIPTION
DEVICE_STATUS	0x00	1	R	0	Status register
GPAI	0x01, 0x02	1	R	0	GPAI measurement data
VCELL1	0x03, 0x04	1	R	0	Cell 1 voltage data
VCELL2	0x05, 0x06	1	R	0	Cell 2 voltage data
VCELL3	0x07, 0x08	1	R	0	Cell 3 voltage data
VCELL4	0x09, 0x0a	1	R	0	Cell 4 voltage data
VCELL5	0x0b, 0x0c	1	R	0	Cell 5 voltage data
VCELL6	0x0d, 0x0e	1	R	0	Cell 6 voltage data
TEMPERATURE1	0x0f, 0x10	1	R	0	TS1+ to TS1– differential voltage data
TEMPERATURE2	0x11, 0x12	1	R	0	TS2+ to TS2– differential voltage data
RSVD	0x13–0x1f	–	–	–	Reserved for future use
ALERT_STATUS	0x20	2	R/W	0x80	Indicates source of ALERT signal
FAULT_STATUS	0x21	2	R/W	0x08	Indicates source of FAULT signal
COV_FAULT	0x22	1	R	0	Indicates cell in OV fault state
CUV_FAULT	0x23	1	R	0	Indicates cell in UV fault state
PRESULT_A	0x24	1	R	0	Parity result of Group3 protected registers (A)
PRESULT_B	0x25	1	R	0	Parity result of Group3 protected registers (B)
RSVD	0x26–0x2f	–	–	–	Reserved for future use
ADC_CONTROL	0x30	2	R/W	0	ADC measurement control
IO_CONTROL	0x31	2	R/W	0	I/O pin control
CB_CTRL	0x32	2	R/W	0	Controls the state of the cell-balancing outputs CBx
CB_TIME	0x33	2	R/W	0	Configures the CB control FETs maximum on time
ADC_CONVERT	0x34	2	R/W	0	ADC conversion start
RSVD	0x35–0x39	–	–	–	Reserved for future use
SHDW_CTRL	0x3a	2	R/W	0	Controls WRITE access to Group3 registers
ADDRESS_CONTROL	0x3b	2	R/W	0	Address register
RESET	0x3c	2	W	0	RESET control register
TEST_SELECT	0x3d	2	R/W	0	Test mode selection register
RSVD	0x3e	–	–	–	Reserved for future use
E_EN	0x3f	2	R/W	0	EPROM programming mode enable
FUNCTION_CONFIG	0x40	3	R/W	EPROM	Default configuration of device
IO_CONFIG	0x41	3	R/W	EPROM	I/O pin configuration
CONFIG_COV	0x42	3	R/W	EPROM	Overvoltage set point
CONFIG_COVT	0x43	3	R/W	EPROM	Overvoltage time-delay filter
CONFIG_CUV	0x44	3	R/W	EPROM	Undervoltage setpoint
CONFIG_CUVT	0x45	3	R/W	EPROM	Undervoltage time-delay filter
CONFIG_OT	0x46	3	R/W	EPROM	Overtemperature set point
CONFIG_OTT	0x47	3	R/W	EPROM	Overtemperature time-delay filter
USER1	0x48	3	R	EPROM	User data register 1, not used by device
USER2	0x49	3	R	EPROM	User data register 2, not used by device
USER3	0x4a	3	R	EPROM	User data register 3, not used by device
USER4	0x4b	3	R	EPROM	User data register 4, not used by device
RSVD	0x4c–0xff	–	–	–	Reserved

(1) Key: R = Read; W = Write

7.6.3 Register Details

7.6.3.1 DEVICE_STATUS Register (0x00)

The STATUS register provides information about the current state of the bq76PL536A.

图 27. DEVICE_STATUS Register

7	6	5	4	3	2	1	0
ADDR_RQST	FAULT	ALERT	Reserved	ECC_COR	UVLO	CBT	DRDY

表 6. DEVICE_STATUS Register Field Descriptions

Bit	Field	Type	Reset	Description
7	ADDR_RQST			This bit is written to indicate that the ADDR[0]...[5] bits have been written to the correct address. This bit is a copy of in the ADDRESS_CONTROL[AR] bit. 0 = Address has not been assigned 1 = Address has been assigned
6	FAULT			This bit indicates that this bq76PL536A has detected a condition causing the FAULT signal to become asserted. 0 = No FAULT exists 1 = A FAULT exists. Read FAULT_STATUS to determine the cause.
5	ALERT			This bit indicates that this bq76PL536A has detected a condition causing the ALERT pin to become asserted. 0 = No ALERT exists 1 = An ALERT exists. Read ALERT_STATUS to determine the cause.
4	Reserved			
3	ECC_COR			This bit indicates a one-bit error has been detected and corrected in the EPROM. 0 = No errors are detected in the EPROM 1 = A one-bit (single bit) error has been detected and corrected by on-chip logic.
2	UVLO			This bit indicates the device VBAT has fallen below the undervoltage lockout trip point. Some device operations are not valid in this condition. 0 = Normal operation 1 = UVLO trip point reached, device operation is not ensured.
1	CBT			This bit indicates the cell balance timer is running. 0 = The cell balance timer is has not started or has expired. 1 = The cell balance timer is running.
0	DRDY			This bit indicates the data is ready to read (no conversions active). 0 = There are conversions running. 1 = There are no conversions running.

7.6.4 GPAI (0x01, 0x02) Register

The GPAI register reports the ADC measurement of GPAI+/GPAI– in units of LSBs.

Bits 15–8 are returned at address 0x01, bits 7–0 at address 0x02.

☒ **28. GPAI (0x01, 0x02) Register**

15	14	13	12	11	10	9	8
GPAI[15]	GPAI[14]	GPAI[13]	GPAI[12]	GPAI[11]	GPAI[10]	GPAI[9]	GPAI[8]
7	6	5	4	3	2	1	0
GPAI [7]	GPAI [6]	GPAI [5]	GPAI [4]	GPAI [3]	GPAI [2]	GPAI [1]	GPAI [0]

7.6.5 VCELLn Register (0x03...0x0e)

The VCELLn registers report the converted data for cell n, where n = 1 to 6.

Bits 15–8 are returned at odd addresses (for example, 0x03), bits 7–0 at even addresses (for example, 0x04).

☒ **29. VCELLn Register**

15	14	13	12	11	10	9	8
VCELLn[15]	VCELLn[14]	VCELLn[13]	VCELLn[12]	VCELLn[11]	VCELLn[10]	VCELLn[9]	VCELLn[8]
7	6	5	4	3	2	1	0
VCELLn[7]	VCELLn[6]	VCELLn[5]	VCELLn[4]	VCELLn[3]	VCELLn[2]	VCELLn[1]	VCELLn[0]

7.6.6 TEMPERATURE1 Register (0x0f, 0x10)

The TEMPERATURE1 register reports the converted data for TS1+ to TS1–.

Bits 15–8 are returned at odd addresses (for example, 0x0f), bits 7–0 at even addresses (for example, 0x10).

☒ **30. TEMPERATURE1 Register**

15	14	13	12	11	10	9	8
TEMP1[15]	TEMP1[14]	TEMP1[13]	TEMP1[12]	TEMP1[11]	TEMP1[10]	TEMP1[9]	TEMP1[8]
7	6	5	4	3	2	1	0
TEMP1[7]	TEMP1[6]	TEMP1[5]	TEMP1[4]	TEMP1[3]	TEMP1[2]	TEMP1[1]	TEMP1[0]

7.6.7 TEMPERATURE2 Register (0x11, 0x12)

The TEMPERATURE2 register reports the converted data for TS2+ to TS2–.

Bits 15–8 are returned at odd addresses (for example, 0x11), bits 7–0 at even addresses (for example, 0x12).

☒ **31. TEMPERATURE2 Register**

15	14	13	12	11	10	9	8
TEMP2[15]	TEMP2[14]	TEMP2[13]	TEMP2[12]	TEMP2[11]	TEMP2[10]	TEMP2[9]	TEMP2[8]
7	6	5	4	3	2	1	0
TEMP2[7]	TEMP2[6]	TEMP2[5]	TEMP2[4]	TEMP2[3]	TEMP2[2]	TEMP2[1]	TEMP2[0]

7.6.8 ALERT_STATUS Register (0x20)

The ALERT_STATUS register provides information about the source of the ALERT signal. The host must clear each alert flag by writing a 1 to the bit that is set. The exception is bit 4, which may be written 1 or 0 as needed to implement self-test of the IC stack and wiring.

图 32. ALERT_STATUS Register

7	6	5	4	3	2	1	0
AR	PARITY	ECC_ERR	FORCE	TSD	SLEEP	OT2	OT1

表 7. ALERT_STATUS Register Field Descriptions

Bit	Field	Type	Reset	Description
7	AR			This bit indicates that the ADDR[0]...[5] bits have been written to a valid address. This bit is an inverted copy of the ADDRESS_CONTROL[AR] bit. It is not cleared until an address has been programmed in ADDRESS_CONTROL and a 1 followed by a 0 (two writes) is written to the bit. 0 = Address has been assigned. 1 = Address has not been assigned (default at RESET).
6	PARITY			This bit is used to validate the contents of the protected Group3 registers. 0 = Group3 protected register(s) contents are valid. 1 = Group3 protected register(s) contents are invalid. Group3 registers should be refreshed from OTP or directly written from the host.
5	ECC_ERR			This bit is used to validate the OTP register blocks. 0 = No double-bit errors (a corrected one-bit error may/may not exist) 1 = An uncorrectable error has been detected in the OTP-EPROM register bank. OTP-EPROM register(s) are not valid.
4	FORCE			This bit asserts the ALERT signal. It can be used to verify correct operation and connectivity of the ALERT as a part of system self-test. 0 = De-assert ALERT (default) 1 = Assert the ALERT signal.
3	TSD			This bit indicates thermal shutdown is active. 0 = Thermal shutdown is inactive (default). 1 = Die temperature has exceeded T _{SD} .
2	SLEEP			This bit indicates SLEEP mode was activated. This bit is only set when SLEEP is first activated; no continuous ALERT or SLEEP status is indicated after the host resets the bit, even if the IO_CTRL[SLEEP] bit remains true. (See IO_CTRL register for details.) 0 = Normal operation 1 = SLEEP mode was activated.
1	OT2			This bit indicates an overtemperature fault has been detected via TS2. 0 = Temperature is lower than or equal to the V _{OT2} (or input disabled by IO_CONTROL[TS2] = 0). 1 = Temperature is higher than V _{OT2} .
0	OT1			This bit indicates an overtemperature fault has been detected via TS1. 0 = Temperature is lower than or equal to the V _{OT1} (or input disabled by IO_CONTROL[TS1] = 0). 1 = Temperature is higher than V _{OT1} .

7.6.9 FAULT_STATUS Register (0x21)

The FAULT_STATUS register provides information about the source of the FAULT signal. The host must clear each fault flag by writing a 1 to the bit that is set. The exception is bit 4, which may be written 1 or 0 as needed to implement self-test of the IC stack and wiring.

图 33. FAULT_STATUS Register

7	6	5	4	3	2	1	0
Reserved		I_FAULT	FORCE	POR	CRC	CUV	COV

表 8. FAULT_STATUS Register Field Descriptions

Bit	Field	Type	Reset	Description
7-6	Reserved			
5	I_FAULT			<p>The device has failed an internal register consistency check. Measurement data and protection function status may not be accurate and should not be used.</p> <p>0 = No internal register consistency check fault exists.</p> <p>1 = The internal consistency check has failed self-test. The host should attempt to reset the device, see the <i>RESET</i> section. If the fault persists, the failure should be considered uncorrectable.</p>
4	FORCE			<p>This bit asserts the FAULT signal. It can be used to verify correct operation and connectivity of the FAULT line as a part of system self-test.</p> <p>0 = Deassert FAULT (default)</p> <p>1 = Assert the FAULT signal</p>
3	POR			<p>This bit indicates a power-on reset (POR) has occurred.</p> <p>0 = No POR has occurred since this bit was last cleared by the host.</p> <p>1 = A POR has occurred. This notifies the host that default values have been loaded to Group1 and Group2 registers, and OTP contents have been copied to Group3 registers.</p>
2	CRC			<p>This bit indicates a garbled packet reception by the device.</p> <p>0 = No errors</p> <p>1 = A CRC error was detected in the last packet received.</p>
1	CUV			<p>This bit indicates that this bq76PL536A has detected a cell undervoltage (CUV) condition. Examine CUV_FAULT to determine which cell caused the ALERT.</p> <p>0 = All cells are above the CUV threshold (default).</p> <p>1 = One or more cells is below the CUV threshold.</p>
0	COV			<p>This bit indicates that this bq76PL536A has detected a cell overvoltage (COV) condition. Examine COV_FAULT to determine which cell caused the FAULT.</p> <p>0 = All cells are above the COV threshold (default).</p> <p>1 = One or more cells is below the COV threshold.</p>

7.6.10 COV_FAULT Register (0x22)
☒ 34. COV_FAULT Register

7	6	5	4	3	2	1	0
Reserved		OV[6]	OV[5]	OV[4]	OV[3]	OV[2]	OV[1]

LEGEND: R/W = Read/Write; R = Read only; -n = value after reset

表 9. COV_FAULT Register Field Descriptions

Bit	Field	Type	Reset	Description
7-6	Reserved			
5-0	OV[6]..[1]			These bits indicate which cell caused the DEVICE_STATUS[COV] flag to be set. 0 = Cell[n] does not have an overvoltage fault (default). 1 = Cell[n] does have an overvoltage fault.

7.6.11 CUV_FAULT Register (0x23)
☒ 35. CUV_FAULT Register

7	6	5	4	3	2	1	0
Reserved		UV[6]	UV[5]	UV[4]	UV[3]	UV[2]	UV[1]

LEGEND: R/W = Read/Write; R = Read only; -n = value after reset

表 10. CUV_FAULT Register Field Descriptions

Bit	Field	Type	Reset	Description
7-6	Reserved			
5-0	UV[6]..[1]			These bits indicate which cell caused the DEVICE_STATUS[CUV] flag to be set. 0 = Cell[n] does not have an undervoltage fault (default). 1 = Cell[n] does have an undervoltage fault.

7.6.12 PARITY_H Register (0x24) (PRESULT_A (R/O))

The PRESULT_A register holds the parity result bits for the first eight Group3 protected registers.

☒ 36. PARITY_H Register

7	6	5	4	3	2	1	0
OTT	OTV	CUVT	CUVV	COVT	COVV	IO	FUNC

7.6.13 PARITY_H Register (0x25) (PRESULT_B (R/O))

The PRESULT_B register holds the parity result bits for the second eight Group3 protected registers.

☒ 37. PARITY_H Register

7	6	5	4	3	2	1	0
Reserved				USER4	USER3	USER2	USER1

7.6.14 ADC_CONTROL Register (0x30)

The ADC_CONTROL register controls some features of the bq76PL536A.

☒ 38. ADC_CONTROL Register

7	6	5	4	3	2	1	0
Reserved	ADC_ON	TS2	TS1	GPAI	CELL_SEL[2]	CELL_SEL[1]	CELL_SEL[0]

LEGEND: R/W = Read/Write; R = Read only; -n = value after reset

表 11. ADC_CONTROL Register Field Descriptions

Bit	Field	Type	Reset	Description
7	Reserved			Must be written as 0.
6	ADC_ON			This bit forces the ADC subsystem ON. This has the effect of eliminating internal start-up and settling delays, but increases current consumption. 0 = Auto mode. ADC subsystem is OFF until a conversion is requested. The ADC is turned on, a wait is applied to allow the reference to stabilize. Automatically returns to OFF state at end of requested conversion. Note that there is a start-up delay associated with turning the ADC to the ON state in this mode. 1 = ADC subsystem is ON, regardless of conversion state. Power consumption is increased.
5-4	TS[1]..[0]			These two bits select whether any of the temperature sensor inputs are to be measured on the next conversion sequence start. Refer to 表 12.
3	GPAI			This bit enables and disables the GPAI input to be measured on the next conversion-sequence start. 0 = GPAI is not selected for measurement. 1 = GPAI is selected for measurement.
2-0	CELL_SEL[2]..[0]			These three bits select the series cells for voltage measurement translation on the next conversion sequence start. Refer to 表 13.

表 12. Temperature sensor Inputs

TS[1]	TS[0]	MEASURE T
0	0	None (default)
0	1	TS1
1	0	TS2
1	1	Both

表 13. Series Cells for Voltage Measurement Translation

CELL_SEL[2]	CELL_SEL[1]	CELL_SEL[0]	SELECTED CELL
0	0	0	Cell 1 only
0	0	1	Cells 1-2
0	1	0	Cells 1-2-3
0	1	1	Cells 1-2-3-4
1	0	0	Cells 1-2-3-4-5
1	0	1	Cells 1-2-3-4-5-6
Other			Cell 1 only

7.6.15 IO_CONTROL Register (0x31)

The IO_CONTROL register controls some features of the bq76PL536A external I/O pins.

☒ **39. IO_CONTROL Register**

7	6	5	4	3	2	1	0
AUX	GPIO_OUT	GPIO_IN	Reserved		SLEEP	TS2	TS1

表 14. IO_CONTROL Register Field Descriptions

Bit	Field	Type	Reset	Description
7	AUX			Controls the state of the AUX output pin, which is internally connected to REG50. 0 = Open 1 = Connected to REG50
6	GPIO_OUT			Controls the state of the open-drain GPIO output pin; the pin should be programmed to 1 to use the GPIO pin as an input. 0 = Output low 1 = Open-drain
5	GPIO_IN			Represents the input state of GPIO pin when used as an input 0 = GPIO input is low 1 = GPIO input is high
4-3	Reserved			
2	SLEEP			Places the device in a low-quiescent-current state. All CUV, COV, and OT comparators are disabled. A 1-ms delay to stabilize the reference voltage is required to exit SLEEP mode and return to active COV, CUV monitoring. 0 = ACTIVE mode 1 = SLEEP mode
1-0	TSx			Controls the connection of the TS1:TS2 inputs to the ADC VSS connection point. When set, the TSx(–) input is connected to VSS. These bits should be set to 0 to reduce the current draw of the system. 0 = Not connected 1 = Connected

7.6.16 CB_CTRL Register (0x32)

The CB_CTRL register determines the internal cell balance output state.

☒ **40. CB_CTRL Register**

7	6	5	4	3	2	1	0
Reserved		CBAL[6]	CBAL[5]	CBAL[4]	CBAL[3]	CBAL[2]	CBAL[1]

表 15. CB_CTRL Register Field Descriptions

Bit	Field	Type	Reset	Description
7-6	Reserved			
5-0	CBAL[n]			CB_CTRL b(n = 5 to 0) (CBAL(n + 1)): This bit determines if the CB(n) output is high or low. 0 = CB[n] output is low (default). 1 = CB[n] output is high (active).

7.6.17 CB_TIME Register (0x33)

The CB_TIME register sets the maximum high (active) time for the cell balance outputs from 0 seconds to 63 minutes. When set to 0, no balancing can occur – balancing is effectively disabled.

图 41. CB_TIME Register

7	6	5	4	3	2	1	0
CBT[7]	Reserved	CBT[5]	CBT[4]	CBT[3]	CBT[2]	CBT[1]	CBT[0]

表 16. CB_TIME Register Field Descriptions

Bit	Field	Type	Reset	Description
7	CBT[7]			Controls minutes/seconds counting resolution. 0 = Seconds (default) 1 = Minutes
6	Reserved			
5-0	CBT[n]			Sets the time duration as scaled by CBT[7]

7.6.18 ADC_CONVERT Register (0x34)

The CONVERT_CTRL register is used to start conversions.

图 42. ADC_CONVERT Register

7	6	5	4	3	2	1	0
Reserved							CONV

表 17. ADC_CONVERT Register Field Descriptions

Bit	Field	Type	Reset	Description
7-1	Reserved			
0	CONV			This bit starts a conversion, using the settings programmed into the ADC_CONTROL register. It provides a programmatic method of initiating conversions. 0 = No conversion (default) 1 = Initiate conversion. This bit is automatically reset after conversion begins, and always returns 0 on READ.

7.6.19 SHDW_CTRL Register (0x3a)

The SHDW_CTRL register controls writing to Group3 protected registers. Default at RESET = 0x00.

The value 0x35 must be written to this register to allow writing to Group3 protected registers in the range 0x40–0x4f. The register always returns 0x00 on read. The register is reset to 0x00 after any successful write, including a write to non-Group3 registers. A read operation does not reset this register.

Writing the value 0x27 results in all Group3 protected registers being refreshed from OTP programmed values. The register is reset to 0x00 after the REFRESH is complete.

图 43. SHDW_CTRL Register

7	6	5	4	3	2	1	0
SHDW[7]	SHDW[6]	SHDW[5]	SHDW[4]	SHDW[3]	SHDW[2]	SHDW[1]	SHDW[0]

7.6.20 ADDRESS_CONTROL Register (0x3b)

The ADDRESS_CONTROL register allows the host to assign an address to the bq76PL536A for communication. The default for this register is 0x00 at RESET.

☒ 44. ADDRESS_CONTROL Register

7	6	5	4	3	2	1	0
ADDR_RQST	Reserved	ADDR[5]	ADDR[4]	ADDR[3]	ADDR[2]	ADDR[1]	ADDR[0]

表 18. ADDRESS_CONTROL Register Field Descriptions

Bit	Field	Type	Reset	Description
7	ADDR_RQST			This bit is written to indicate that the ADDR[0]...[5] bits have been written to the correct address. This bit is reflected in the DEVICE_STATUS[AR] bit. 0 = Address has not been assigned (default at RESET). 1 = Address has been assigned.
6	Reserved			
5-0	ADDR[n]			These bits set the device address for SPI communication. This provides to a range of addresses from 0x00 to 0x3f. Address 0x3f is reserved for broadcast messages to all connected and addressed 76PL536 devices. The default for these 6 bits is 0x00 at RESET.

7.6.21 RESET Register (0x3c)

The RESET register allows the host to reset the bq76PL536A directly.

Writing 0xa5 causes the device to RESET. Other values are ignored.

☒ 45. RESET Register

7	6	5	4	3	2	1	0
RST[7]	RST[6]	RST[5]	RST[4]	RST[3]	RST[2]	RST[1]	RST[0]

7.6.22 TEST_SELECT Register (0x3d)

The TEST_SELECT places the SPI port in a special mode useful for debug.

TSEL (b7–b0) is used to place the SPI_H interface pins in a mode to support test/debug of a string of bq76PL536A devices. 0 = normal operating mode.

When the sequence 0xa4, 0x25 ("JR") is written on subsequent write cycles, the device enters a special TEST mode useful for stack debugging. Writes to other registers between the required sequence bytes results in the partial sequence being voided; the entire sequence must be written again. POR, RESET, or writing a 0x00 to this register location exits this mode.

In this state, SPI pin SCLK and SDI become outputs and are enabled, and reflect the state of the SCLK_S, SDI_S pins of the device. SDO remains an output. This allows observation of bus traffic mid-string. The lowest device in the string should **not** be set to operate in this mode.

注意

The user is cautioned to condition the connection to a mid- or top-string device with suitable isolation circuitry to prevent injury or damage to connected devices. Programming the most-negative device on the stack in this mode prevents further communications with the stack until POR, and may result in device destruction; this condition should be avoided.

图 46. TEST_SELECT Register

7	6	5	4	3	2	1	0
TSEL[7]	TSEL[6]	TSEL[5]	TSEL[4]	TSEL[3]	TSEL[2]	TSEL[1]	TSEL[0]

7.6.23 E_EN Register (0x3f)

The E_EN register controls the access to the programming of the integrated OTP EPROM.

This register should be written the value 0x91 to permit writing the USER block of EPROM. Values other than 0x00 and 0x91 are reserved and may result in undefined operation. The next read or write of any type to the device resets (closes) the write window. If a Group3 protected write occurs, the window is closed after the write.

图 47. E_EN Register

7	6	5	4	3	2	1	0
E_EN[7]	E_EN[6]	E_EN[5]	E_EN[4]	E_EN[3]	E_EN[2]	E_EN[1]	E_EN[0]

7.6.24 FUNCTION_CONFIG Register (0x40)

The FUNCTION_CONFIG sets the default configuration for special features of the device.

☒ **48. FUNCTION_CONFIG Register**

7	6	5	4	3	2	1	0
0	0	GPAI_REF	GPAI_SRC	CN[1]	CN[0]	Reserved	

表 19. FUNCTION_CONFIG Register Field Descriptions

Bit	Field	Type	Reset	Description
7-6	Reserved			
5	GPAI_REF			This bit sets the reference for the GPAI ADC measurement. 0 = Internal ADC bandgap reference 1 = V_{REG50} (ratiometric)
4	GPAI_SRC			This bit controls multiplexing of the GPAI register and determines whether the ADC mux is connected to the external GPAI inputs, or internally to the BAT1 pin. The register results are automatically scaled to match the input. 0 = External GPAI inputs are converted to result in GPAI register 0x01–02. 1 = BAT pin to VSS voltage is measured and reported in the GPAI register.
3-2	CN[n]			These two bits configure the number of series cells used. If fewer than 6 cells are configured, the corresponding OV/UV faults are ignored. For example, if the CN[x] bits are set to 10b (2), then the OV/UV comparators are ignored for cells 5 and 6. Refer to 表 20 .
1-0	Reserved			

表 20. Series Cells

CN[1]	CN[0]	Series Cells
0	0	6 (DEFAULT)
0	1	5
1	0	4
1	1	3

7.6.25 IO_CONFIG Register (0x41)

The IO_CONFIG sets the default configuration for miscellaneous I/O features of the device.

☒ 49. IO_CONFIG Register

7	6	5	4	3	2	1	0
CRCNOFLT	Reserved						CRC_DIS

表 21. IO_CONFIG Register Field Descriptions

Bit	Field	Type	Reset	Description
7	CRCNOFLT			This bit enables and disables detected CRC errors asserting the FAULT pin. 0 = CRC errors cause the FAULT[CRC] bit to be set and the FAULT pin to assert. The FAULT[CRC] bit must be reset as described in the text. 1 = CRC errors cause the FAULT[CRC] bit to be set and the FAULT pin is not asserted. The FAULT[CRC] bit must be reset as described in the text.
6-1	Reserved			
0	CRC_DIS			This bit enables and disables the automatic generation of the CRC for the SPI communication packet. The packet size is determined by the host as part of the read request protocol. The CRC is checked at the deassertion of the CS pin. TI recommends that this bit be changed using the broadcast address (0x3f) so that all devices in a battery stack use the same protocol. 0 = A CRC is expected, and generated as the last byte of the packet. 1 = A CRC is not used in communications.

7.6.26 CONFIG_COV Register (0x42)

The CONFIG_COV register determines cell overvoltage threshold voltage.

☒ 50. CONFIG_COV Register

7	6	5	4	3	2	1	0
DISABLE	Reserved	COV[5]	COV[4]	COV[3]	COV[2]	COV[1]	COV[0]

表 22. CONFIG_COV Register Field Descriptions

Bit	Field	Type	Reset	Description
7	DISABLE			Disables the overvoltage function when set. 0 = Overvoltage function enabled 1 = Overvoltage function disabled
6	Reserved			
5-0	COV[n]			Configuration bits with corresponding voltage threshold 0x00 = 2 V; each binary increment adds 50 mV until 0x3c = 5 V

7.6.27 CONFIG_COVT Register (0x43)

The CONFIG_COVT register determines cell overvoltage detection delay time.

☒ **51. CONFIG_COVT Register**

7	6	5	4	3	2	1	0
μs/ms	Reserved		COVD[4]	COVD[3]	COVD[2]	COVD[1]	COVD[0]

表 23. CONFIG_COVT Register Field Descriptions

Bit	Field	Type	Reset	Description
7	μs/ms			Determines the units of the delay time, microseconds or milliseconds 0 = Microseconds 1 = Milliseconds
6-5	Reserved			
4-0	COVD[n]			0x01 = 100; each binary increment adds 100 until 0x1f = 3100 Note: When this register is programmed to 0x00, the delay becomes 0s AND the COV state is NOT latched in the COV_FAULT register. In this operating mode, the overvoltage state for a cell is virtually instantaneous in the COV_FAULT register. This mode may cause system firmware to miss a dangerous cell overvoltage condition.

7.6.28 CONFIG_UV Register (0x44)

The CUV register determines cell under voltage threshold voltage.

☒ **52. CONFIG_UV Register**

7	6	5	4	3	2	1	0
DISABLE	Reserved		CUV[4]	CUV[3]	CUV[2]	CUV[1]	CUV[0]

表 24. CONFIG_UV Register Field Descriptions

Bit	Field	Type	Reset	Description
7	DISABLE			Disables the undervoltage function when set 0 = Undervoltage function enabled 1 = Undervoltage function disabled
6-5	Reserved			
4-0	COVD[n]			Configuration bits with corresponding voltage threshold 0x00 = 0.7 V; each binary increment adds 100 mV until 0x1a = 3.3 V

7.6.29 CONFIG_CUVT Register (0x45)

The CONFIG_CUVT register determines cell undervoltage detection delay time.

☒ **53. CONFIG_CUVT Register**

7	6	5	4	3	2	1	0
μs/ms	Reserved		CUVD[4]	CUVD[3]	CUVD[2]	CUVD[1]	CUVD[0]

表 25. CONFIG_CUVT Register Field Descriptions

Bit	Field	Type	Reset	Description
7	μs/ms			Determines the units of the delay time, microseconds or milliseconds 0 = Microseconds 1 = Milliseconds
6-5	Reserved			
4-0	CUVD[n]			0x01 = 100; each binary increment adds 100 until 0x1f = 3100 Note: When this register is programmed to 0x00, the delay becomes 0 s AND the CUV state is NOT latched in the CUV_FAULT register. In this operating mode, the undervoltage state for a cell is virtually instantaneous in the CUV_FAULT register. This mode may cause system firmware to miss a dangerous cell undervoltage condition.

7.6.30 CONFIG_OT Register (0x46)

The CONFIG_OT register holds the configuration of the overtemperature thresholds for the two TS inputs.

For each respective nibble (OT1 or OT2), the value 0x0 disables this function. Other settings program a trip threshold. See the *Ratiometric Sensing* section for details of setting this register. Values above 0x0b are illegal and should not be used.

图 54. CONFIG_OT Register

7	6	5	4	3	2	1	0
OT2[3]	OT2[2]	OT2[1]	OT2[0]	OT1[3]	OT1[2]	OT1[1]	OT1[0]

7.6.31 CONFIG_OTT Register (0x47)

The CONFIG_OTT register determines cell overtemperature detection delay time.

0x01 = 10 ms; each binary increment adds 10 ms until 0xff = 2.55 seconds.

注

When this register is programmed to 0x00, the delay becomes 0 s AND the OT state is NOT latched in the ALERT_STATUS register. In this operating mode, the overtemperature state for a TS_n input is virtually instantaneous in the register. This mode may cause system firmware to miss a dangerous overtemperature condition.

图 55. CONFIG_OTT Register

7	6	5	4	3	2	1	0
COTD[7]	COTD[6]	COTD[5]	COTD[4]	COTD[3]	COTD[2]	COTD[1]	COTD[0]

7.6.32 USERx Register (0x48–0x4b) (USER1–4)

The four USER registers can be used to store user data. The part does not use these registers for any internal function. They are provided as convenient storage for user S/N, date of manufacture, and so forth.

图 56. USERx Register

7	6	5	4	3	2	1	0
USER[7]	USER[6]	USER[5]	USER[4]	USER[3]	USER[2]	USER[1]	USER[0]

8 Application and Implementation

注

Information in the following applications sections is not part of the TI component specification, and TI does not warrant its accuracy or completeness. TI's customers are responsible for determining suitability of components for their purposes. Customers should validate and test their design implementation to confirm system functionality.

8.1 Application Information

The bq76PL536A is a series-cell Lithium-Ion battery monitor and secondary protector for Uninterruptible Power Systems (UPS), E-Bikes and Scooters, Large-Format Battery Systems, and so forth. To allow for optimal performance in the end application, special consideration must be taken to ensure minimization of measurement error through proper printed circuit board (PCB) layout.

8.1.1 Anti-Aliasing Filter

An anti-aliasing filter is required for each VCn input VC6–VC1, consisting of a 1-k Ω , 1% series resistor and 100-nF capacitor. Good-quality components should be used. A 1% resistor is recommended, because the resistor creates a small error by forming a voltage divider with the input impedance of the part. The part is factory-trimmed to compensate for the error introduced by the filter.

8.1.2 Host SPI Interface Pin States

The CS_H pin is active-low. The host asserts the pin to a logic zero to initiate communications. The CS pin should remain low until the end of the current packet. When the CS_H pin is asserted, the SPI receiver and interface of the device are reset and resynchronized. This action ensures that a slave device that has lost synchronization during a previous transmission or as the result of noise on the bus does not remain permanently hung. CS_H must be driven false (high) between packets; see [Timing Characteristics – AC SPI Data Interface](#) for timing details.

8.2 Typical Application

Figure 57 shows the recommended reference design components.

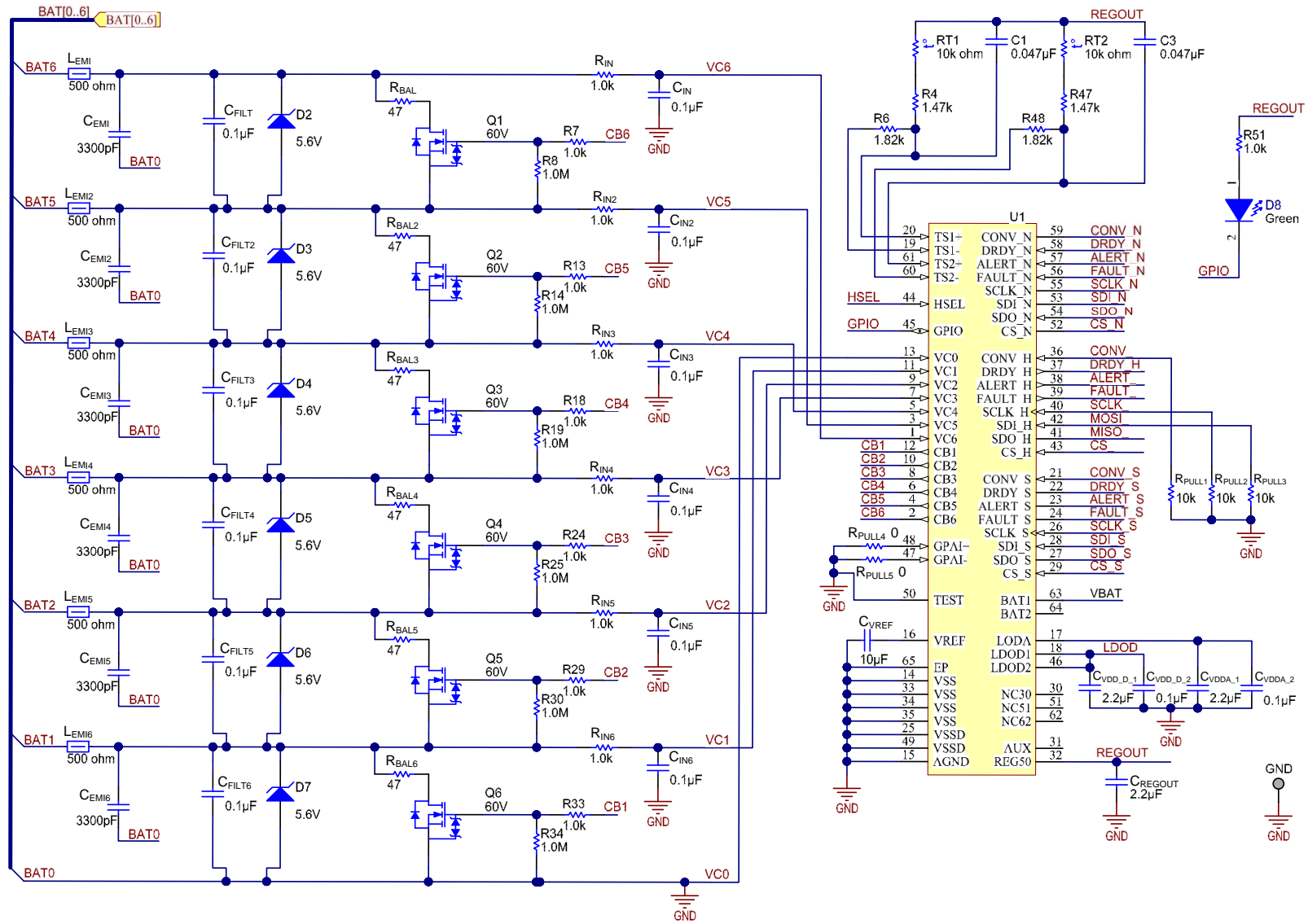

Figure 57. Application Schematic

8.2.1 Design Requirements

For this design example, use the parameters listed in 表 26.

表 26. Design Parameters

PARAMETER	DESCRIPTION	EXAMPLE VALUE	UNIT
C _{EMI}	EMI Capacitor	3300	pF
C _{FILT}	Filter Capacitor	0.1	μF
C _{IN}	Input Capacitor	0.1	μF
C _{REGOUT}	REGOUT Capacitor	2.2 (minimum)	μF
C _{VDDA_1}	Internal analog 5-V LDO bypass connection 1	2.2	μF
C _{VDDA_2}	Internal analog 5-V LDO bypass connection 2	0.2	μF
C _{VDD_D_1}	Capacitor for internal digital 5-V LDO bypass connection 1	2.2	μF
C _{VDD_D_2}	Capacitor for internal digital 5-V LDO bypass connection 2	0.2	μF
C _{VREF}	VREF Capacitor	10	μF
L _{EMI}	EMI Ferrite Resistor	500	Ω
R _{BAL}	Balance Resistor	47	Ω
R _{IN}	Input Resistor	1	kΩ
R _{PULL1} -R _{PULL3}	Pullup Resistors for digital open-drain I/O	10	kΩ
R _{PULL4} -R _{PULL5}	Pullup Resistors for general-purpose (differential) analog input (GPAI), connect to VSS if unused		kΩ

8.2.2 Detailed Design Procedure

Use the following for the procedure for the recommended front-end circuit:

- Select the RC filter closest to the cell for filter requirements. Additional poles can be added with a differential capacitor to get very low f_c .
- ADC is calibrated to use $R_{IN} = 1 \text{ k}\Omega$ and $C_{IN} = 0.1 \text{ }\mu\text{F}$.
- Select Zener diode for lowest possible reverse leakage.
- A balance FET gate-protection diode is required (available internally).
- Select the capacitors for LDO Filters according to 表 26.
 - LDO1 and LDO2 require a 2.2-μF ceramic capacitor for stability. These pins are tied together internally. Tie LDO1 to LDOD2 externally.
- For pullup supply, the following information applies:
 - REG50 turns off in SLEEP mode
 - Use LDOD for pullups in normal use
 - Use REG50 for programming EEPROM (LDOD will see 7 V)
 - Connect GPAI+ and GPA– to VSS if unused
- Select low impedance and polarized connectors. Numbered or colored connectors are also good options.
- Select the input Zener TVS so that it clamps below 5.6 Vdc, with low-leakage current, and must be able to handle transient surge energy
- Select capacitors based on temperature and environment with voltages well above the operating voltage
- Select balancing MOSFETs according to the following:
 - Low turn on threshold voltage (must turn on with the lowest cell voltage)
 - Drain-to-source voltage and gate-to-source voltage
 - Power dissipation
 - Current based on selected bleed resistor value
- Select the Bleed Resistor according to the following:
 - Value based on desired current
 - Wattage to handle the current and temperature rise such as $4.2 \text{ V} \times 47 = 0.089 \text{ A} \therefore 0.37 \text{ W}$

8.2.3 Application Curves

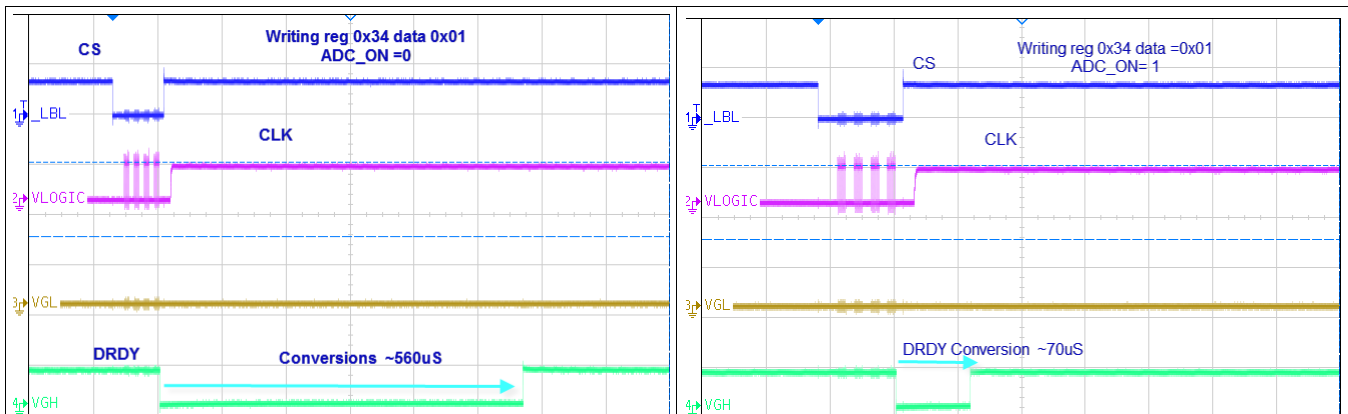

Figure 58. Firmware Conversion with ADC_ON = 0

Figure 59. Firmware Conversion with ADC_ON = 1

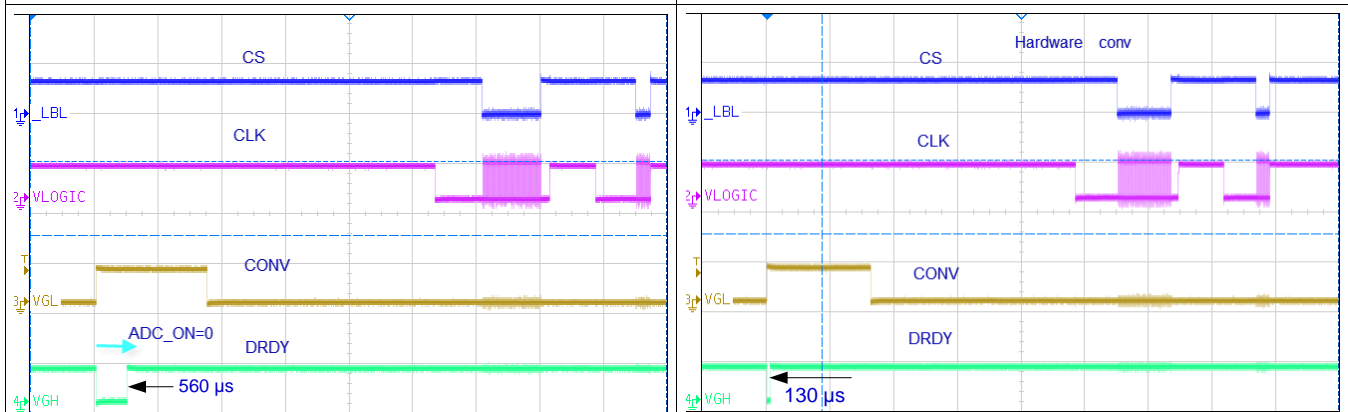

Figure 60. Hardware Conversion with ADC_ON = 0

Figure 61. Hardware Conversion with ADC_ON = 1

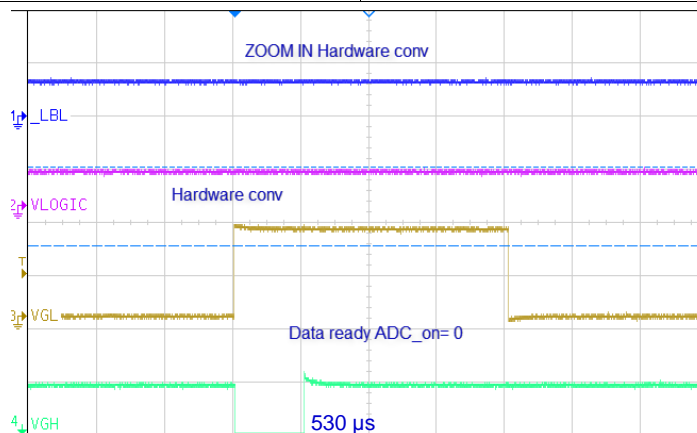

Figure 62. ZOOM IN Hardware Conversion

bq76PL536A

JAJSBH7C –JUNE 2011 –REVISED OCTOBER 2016

www.tij.co.jp

8.3 Other Schematics

The device generic part number, bq76PL536, is shown in these schematics.

Full-size reference schematics are available from TI on request.

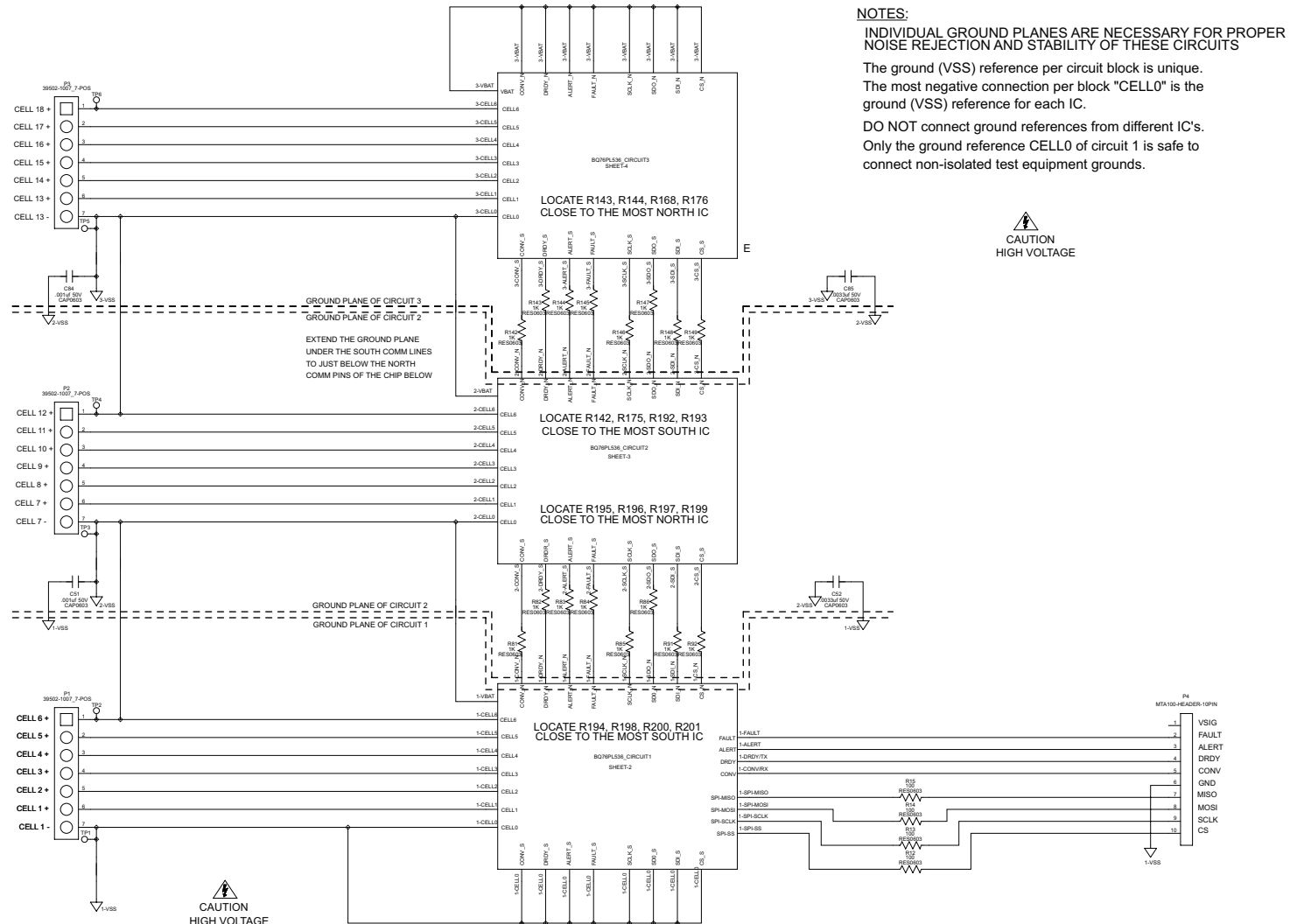

63. Schematic (Page 1 of 4)

S001

Other Schematics (continued)



图 64. Schematic (Page 2 of 4)

S002

Other Schematics (continued)

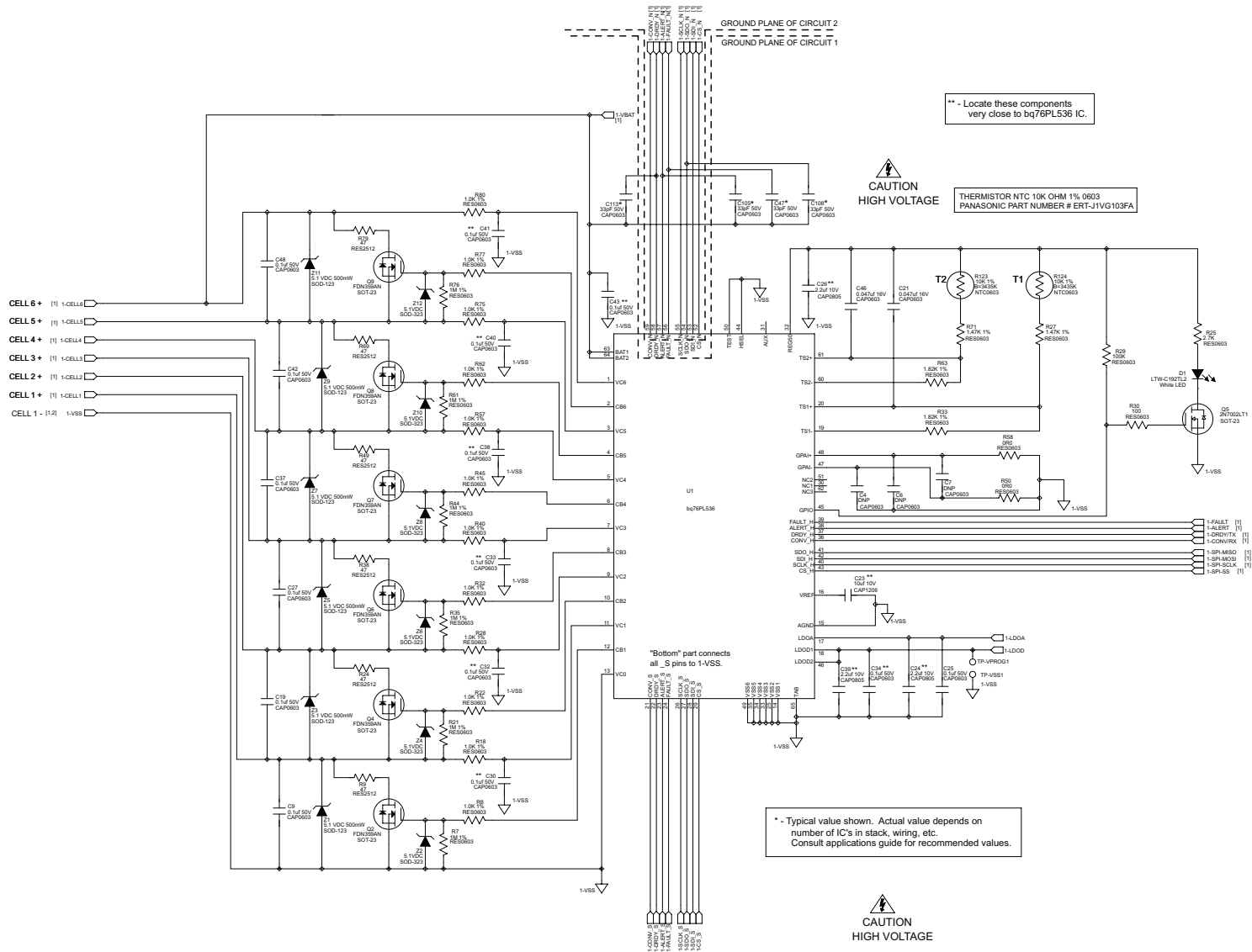
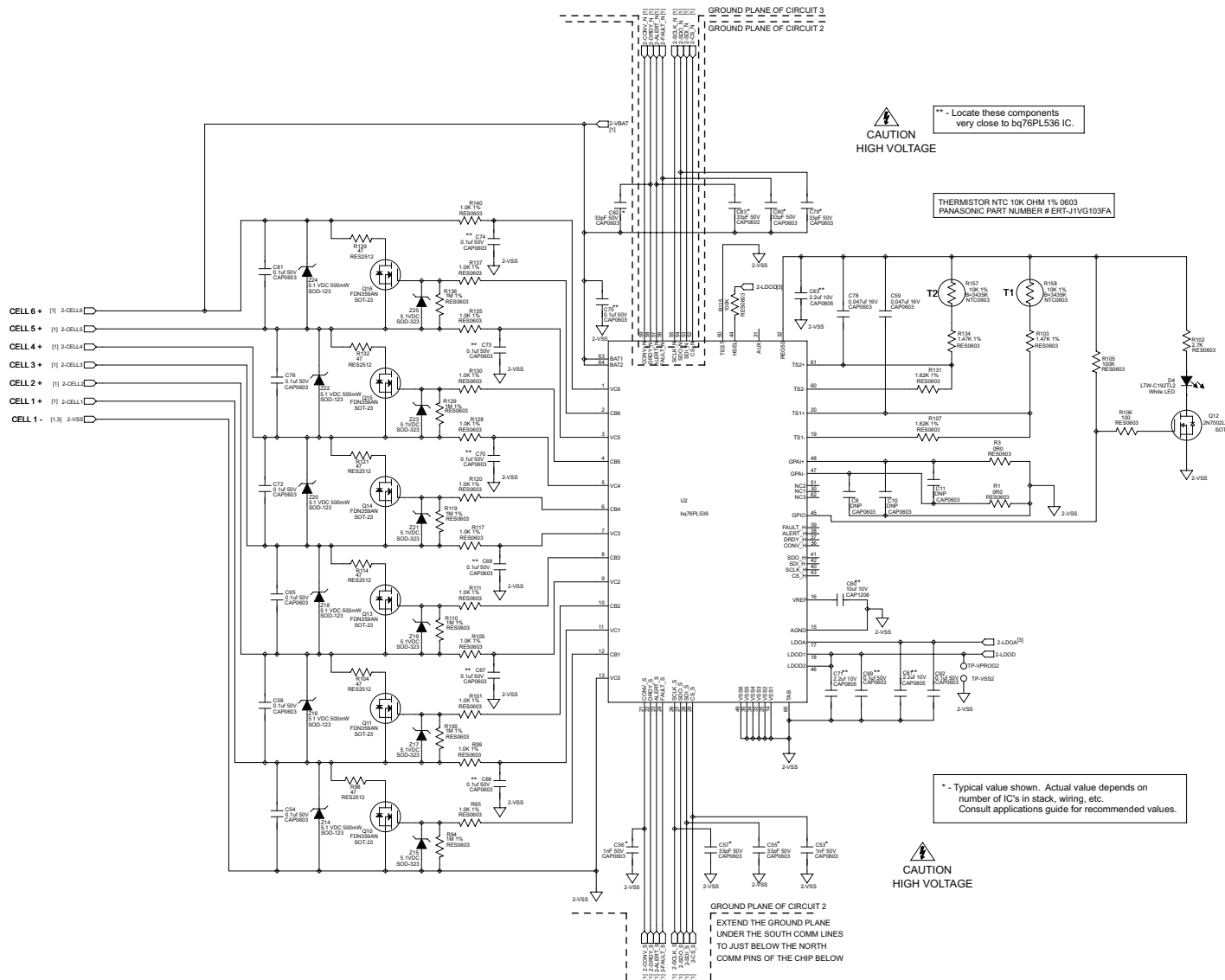

65. Schematic (Page 3 of 4)

Other Schematics (continued)

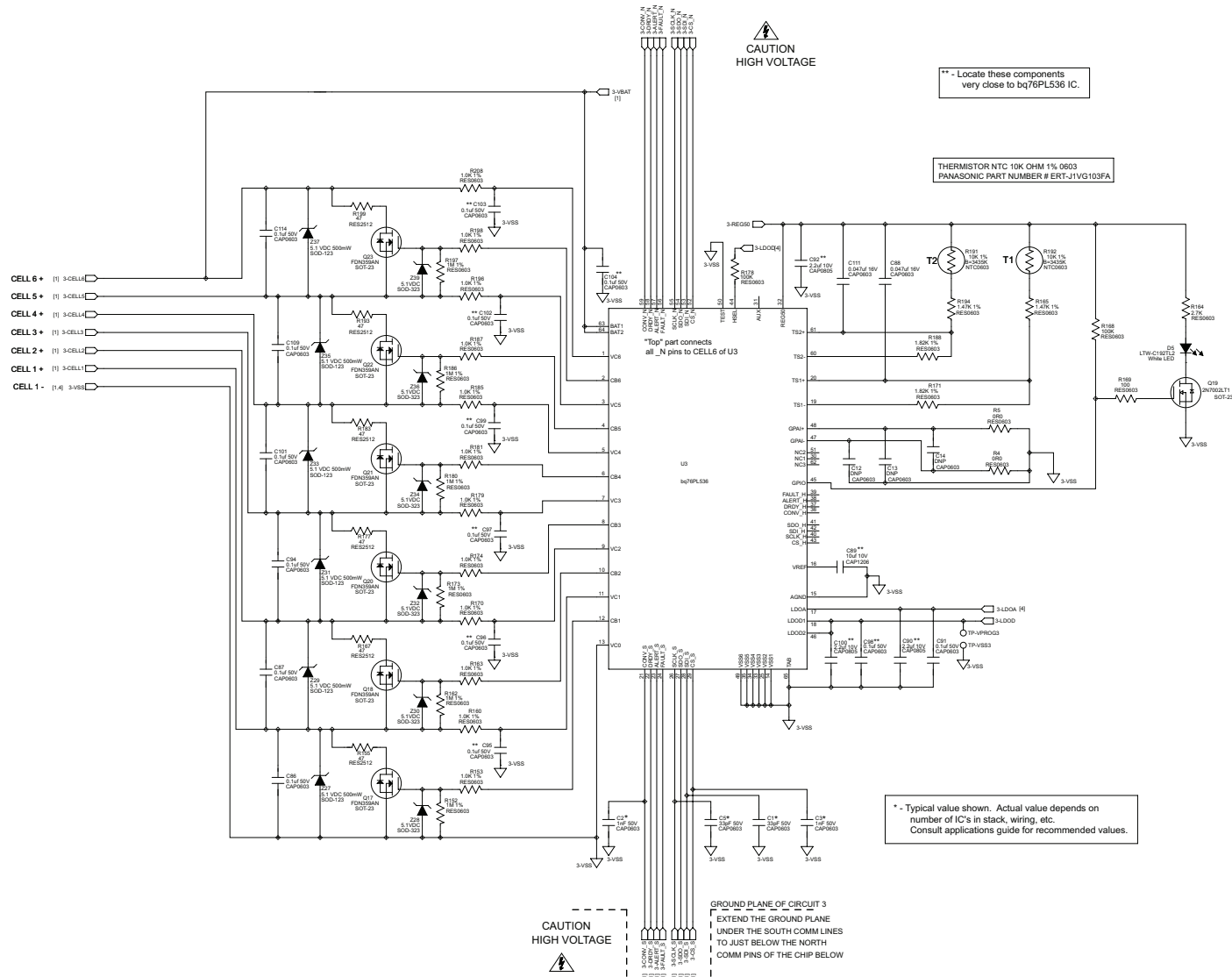

66. Schematic (Page 4 of 4)

bq76PL536A

JAJSBH7C –JUNE 2011 –REVISED OCTOBER 2016

www.tij.co.jp

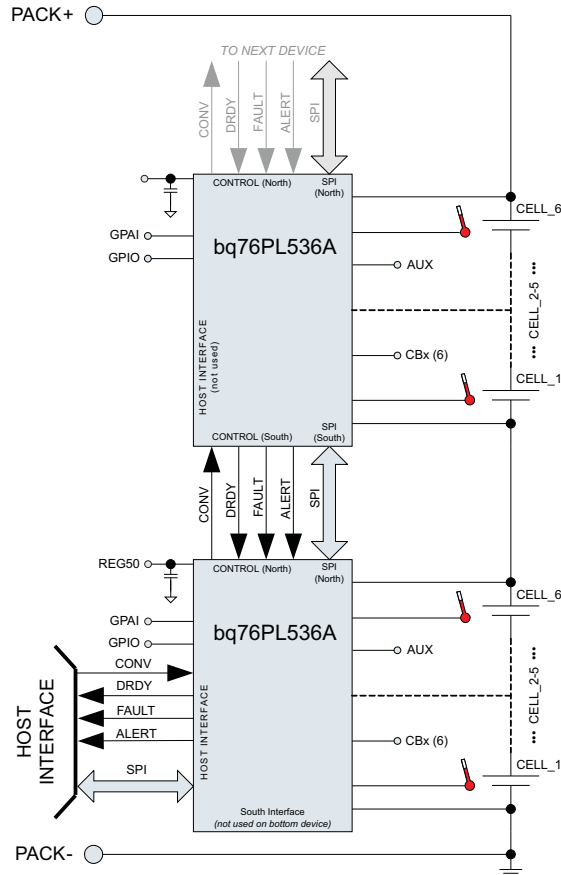

67. Simplified System Connection

9 Power Supply Recommendations

9.1 Power Supply Decoupling

The LDOA, LDOD1, LDOD2 and REG50 pins all require a 2.2- μ F ceramic capacitor to be placed as closely as possible to the respective pins to optimize stability. The bq76PL536A requires a power supply with between 7.2 V to 27 V inputs. When fewer than six cells are used, see [Figure 14](#) for details.

10 Layout

10.1 Layout Guidelines

For typical applications, the following guidelines and practices should be followed closely:

- VREF and AGND pins require a high-quality 10- μ F capacitor be connected between them, in very close physical proximity to the device pins, using short track lengths to minimize the effects of track inductance on signal quality.
 - The AGND pin should be connected to VSS. Device VSS connections should be brought to a single point close to the IC to minimize layout-induced errors. The device tab should also be connected to this point, and is a convenient common VSS location. The internal VREF should not be used externally to the device by user circuits.
- The internal analog supply should be bypassed at the LDOA pin with a good-quality, low-ESR, 2.2- μ F ceramic capacitor.

注

Because the LDODx inputs are pulled to approximately 7 V during programming, programming time MUST be < 50 ms.

- The bq76PL536A has a low-dropout (LDO) regulator provided to power the thermistors and other external circuitry. The input for this regulator is VBAT. The output of REG50 is typically 5 V. A minimum 2.2- μ F capacitor is required for stable operation. The output is internally current-limited and is reduced to near zero, if excess current is drawn, causing die temperatures to rise to unacceptable levels. The 2.2- μ F output capacitor is required whether REG50 is used in the design or not. REG50 is disabled in SLEEP mode, may be turned off under thermal-shutdown conditions, and therefore should not be used as a pull-up source for terminating device pins where required.
- The bq76PL536A includes a general-purpose input/output pin controlled by the IO_CONTROL[GPIO_OUT] bit. The state of this bit is reflected on the pin. To use the pin as an input, program GPIO_OUT to a 1, and then read the IO_CONTROL[GPIO_IN] bit. A pull-up (10 k Ω –1 M Ω , typical) is required on this pin if used as an input. If the pull-up is not included in the design, system firmware must program a 0 in IO_CONTROL[GPIO_OUT] to prevent excess current draw from the floating input. Use of a pull-up is recommended in all designs to prevent an unintentional increase in current draw.
- Device-to-device (D2D) communications makes use of a unique, current-mode interface which provides common-mode voltage isolation between successive bq76PL536As. This vertical bus (VBUS) is found on the _N and corresponding _S pins. It provides high-speed I/O for both the SPI bus and the direct I/O pins CONV and DRDY. The current-mode interface minimizes the effects of wiring capacitance on the interface speed. The _S (south-facing) pins connect to the next-lower device (operating at a lower potential) in the stack of bq76PL536As. The _N (North facing) pins connect to the next-higher device. The pins cannot be swapped; _S always points South, and _N always point North. The _S and _N pins are interconnected to the pin with the same name, but opposite suffix.
 - All pins operate within the voltages present at the BAT and VSS pins.
 - The maximum SCLK frequency is limited by the number of devices in the vertical stack and other factors. Each device imposes an approximately 30-ns delay on the round trip communications speed; that is, from SCLK rise time (an input to all devices) to the SDO pin transition time requires approximately 30 ns per device. The designer must add to this the delay caused by the PCB trace (in turn determined by the material and layout), any connectors in series with the connection, and any other wiring or cabling between devices in the system.
- When designing the layout, several considerations need to be taken into account.

Layout Guidelines (continued)

- First, in a stacked system, individual ground planes are necessary for proper noise rejection and stability of the circuits.
- Second, the ground (VSS) reference per circuit block is unique. The most negative connection, per block “CELL0”, is the ground (VSS) reference for each IC. Do not connect ground references from different ICs. Only the ground reference CELL0, of the most southerly IC, is safe to connect non-isolated test equipment grounds.

注意

Be careful as the BAT and VSS pins may be several hundred volts above system ground, depending on their position in the stack.

注

North (_N) pins of the top, most-positive device in the stack, should be connected to the BAT1(2) pins of the device for correct operation of the string. South (_S) pins of the lowest, most-negative device in the stack, should be connected to VSS of the device.

The PowerPAD™ package is a thermally enhanced standard-size IC package designed to eliminate the use of bulky heat sinks and slugs traditionally used in thermal packages. This package can be easily mounted using standard printed circuit board (PCB) assembly techniques, and can be removed and replaced using standard repair procedures. See [Figure 68](#).

The PowerPAD™ package is designed so that the lead frame die pad (or thermal pad) is exposed on the bottom of the IC. This provides an extremely low-thermal resistance ($R_{\theta JC}$) path between the die and the exterior of the package. The thermal pad on the bottom of the IC can then be soldered directly to the printed circuit board (PCB), using the PCB as a heat sink. In addition, through the use of thermal bias, the thermal pad can be directly connected to a ground plane or special heat sink structure designed into the PCB.

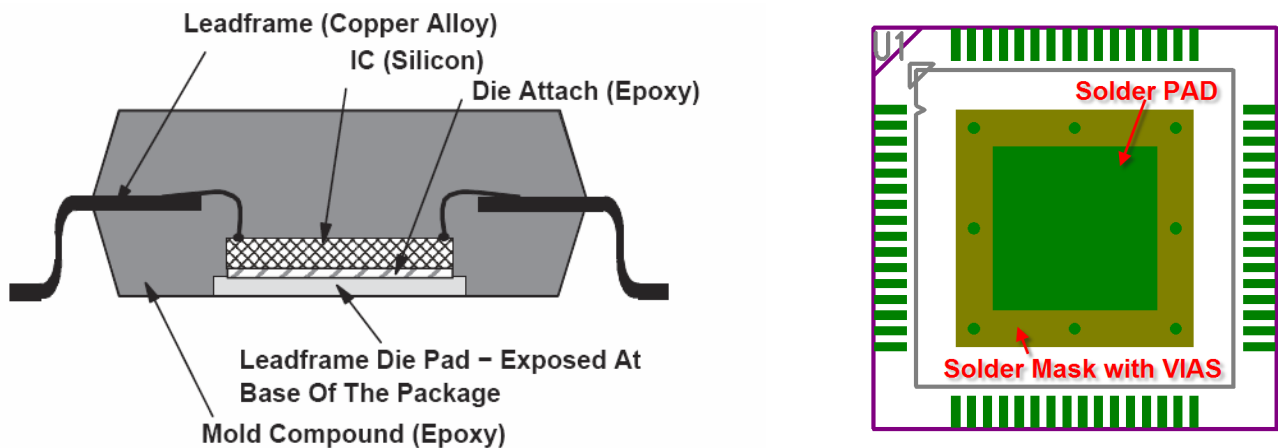
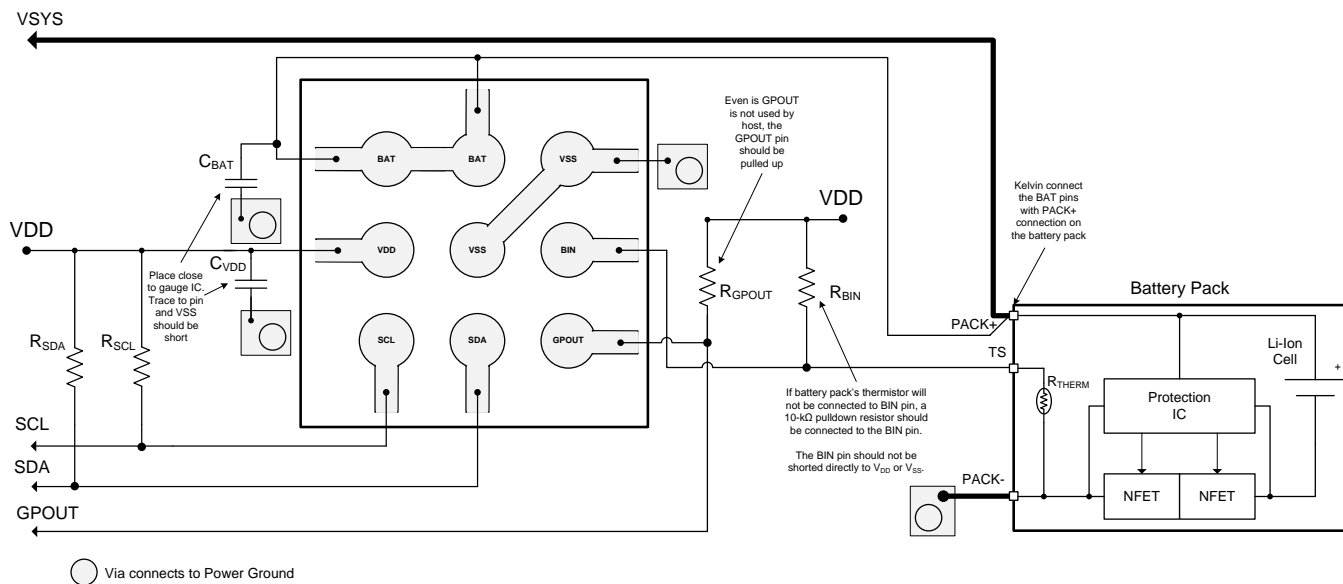

Figure 68. Section View of PowerPAD™ Package and Top View of Solder Mask and PAD

10.2 Layout Example



69. Layout Schematic

11 デバイスおよびドキュメントのサポート

11.1 ドキュメントの更新通知を受け取る方法

ドキュメントの更新についての通知を受け取るには、ti.comのデバイス製品フォルダを開いてください。右上の隅にある「通知を受け取る」をクリックして登録すると、変更されたすべての製品情報に関するダイジェストを毎週受け取れます。変更の詳細については、修正されたドキュメントに含まれている改訂履歴をご覧ください。

11.2 コミュニティ・リソース

The following links connect to TI community resources. Linked contents are provided "AS IS" by the respective contributors. They do not constitute TI specifications and do not necessarily reflect TI's views; see TI's [Terms of Use](#).

TI E2E™ Online Community *TI's Engineer-to-Engineer (E2E) Community*. Created to foster collaboration among engineers. At e2e.ti.com, you can ask questions, share knowledge, explore ideas and help solve problems with fellow engineers.

Design Support *TI's Design Support* Quickly find helpful E2E forums along with design support tools and contact information for technical support.

11.3 商標

PowerPAD, E2E are trademarks of Texas Instruments.
All other trademarks are the property of their respective owners.

11.4 静電気放電に関する注意事項



これらのデバイスは、限定的なESD(静電破壊)保護機能を内蔵しています。保存時または取り扱い時は、MOSゲートに対する静電破壊を防止するために、リード線同士をショートさせておくか、デバイスを導電フォームに入れる必要があります。

11.5 Glossary

SLYZ022 — *TI Glossary*.

This glossary lists and explains terms, acronyms, and definitions.

12 メカニカル、パッケージ、および注文情報

以降のページには、メカニカル、パッケージ、および注文に関する情報が記載されています。この情報は、そのデバイスについて利用可能な最新のデータです。このデータは予告なく変更されることがあり、ドキュメントが改訂される場合もあります。本データシートのブラウザ版を使用されている場合は、画面左側の説明をご覧ください。

PACKAGING INFORMATION

Orderable Device	Status (1)	Package Type	Package Drawing	Pins	Package Qty	Eco Plan (2)	Lead finish/ Ball material (6)	MSL Peak Temp (3)	Op Temp (°C)	Device Marking (4/5)	Samples
BQ76PL536APAPR	ACTIVE	HTQFP	PAP	64	1000	RoHS & Green	NIPDAU	Level-3-260C-168 HR	-40 to 85	BQ76PL536A	Samples
BQ76PL536APAPT	ACTIVE	HTQFP	PAP	64	250	RoHS & Green	NIPDAU	Level-3-260C-168 HR	-40 to 85	BQ76PL536A	Samples

(1) The marketing status values are defined as follows:

ACTIVE: Product device recommended for new designs.

LIFEBUY: TI has announced that the device will be discontinued, and a lifetime-buy period is in effect.

NRND: Not recommended for new designs. Device is in production to support existing customers, but TI does not recommend using this part in a new design.

PREVIEW: Device has been announced but is not in production. Samples may or may not be available.

OBSOLETE: TI has discontinued the production of the device.

(2) **RoHS:** TI defines "RoHS" to mean semiconductor products that are compliant with the current EU RoHS requirements for all 10 RoHS substances, including the requirement that RoHS substance do not exceed 0.1% by weight in homogeneous materials. Where designed to be soldered at high temperatures, "RoHS" products are suitable for use in specified lead-free processes. TI may reference these types of products as "Pb-Free".

RoHS Exempt: TI defines "RoHS Exempt" to mean products that contain lead but are compliant with EU RoHS pursuant to a specific EU RoHS exemption.

Green: TI defines "Green" to mean the content of Chlorine (Cl) and Bromine (Br) based flame retardants meet JS709B low halogen requirements of <=1000ppm threshold. Antimony trioxide based flame retardants must also meet the <=1000ppm threshold requirement.

(3) MSL, Peak Temp. - The Moisture Sensitivity Level rating according to the JEDEC industry standard classifications, and peak solder temperature.

(4) There may be additional marking, which relates to the logo, the lot trace code information, or the environmental category on the device.

(5) Multiple Device Markings will be inside parentheses. Only one Device Marking contained in parentheses and separated by a "~" will appear on a device. If a line is indented then it is a continuation of the previous line and the two combined represent the entire Device Marking for that device.

(6) Lead finish/Ball material - Orderable Devices may have multiple material finish options. Finish options are separated by a vertical ruled line. Lead finish/Ball material values may wrap to two lines if the finish value exceeds the maximum column width.

Important Information and Disclaimer:The information provided on this page represents TI's knowledge and belief as of the date that it is provided. TI bases its knowledge and belief on information provided by third parties, and makes no representation or warranty as to the accuracy of such information. Efforts are underway to better integrate information from third parties. TI has taken and continues to take reasonable steps to provide representative and accurate information but may not have conducted destructive testing or chemical analysis on incoming materials and chemicals. TI and TI suppliers consider certain information to be proprietary, and thus CAS numbers and other limited information may not be available for release.

In no event shall TI's liability arising out of such information exceed the total purchase price of the TI part(s) at issue in this document sold by TI to Customer on an annual basis.

TAPE AND REEL INFORMATION

QUADRANT ASSIGNMENTS FOR PIN 1 ORIENTATION IN TAPE

*All dimensions are nominal

Device	Package Type	Package Drawing	Pins	SPQ	Reel Diameter (mm)	Reel Width W1 (mm)	A0 (mm)	B0 (mm)	K0 (mm)	P1 (mm)	W (mm)	Pin1 Quadrant
BQ76PL536APAPR	HTQFP	PAP	64	1000	330.0	24.4	13.0	13.0	1.5	16.0	24.0	Q2
BQ76PL536APAPT	HTQFP	PAP	64	250	180.0	24.4	13.0	13.0	1.5	16.0	24.0	Q2

TAPE AND REEL BOX DIMENSIONS

*All dimensions are nominal

Device	Package Type	Package Drawing	Pins	SPQ	Length (mm)	Width (mm)	Height (mm)
BQ76PL536APAPR	HTQFP	PAP	64	1000	350.0	350.0	43.0
BQ76PL536APAPT	HTQFP	PAP	64	250	213.0	191.0	55.0

GENERIC PACKAGE VIEW

PAP 64

HTQFP - 1.2 mm max height

10 x 10, 0.5 mm pitch

QUAD FLATPACK

This image is a representation of the package family, actual package may vary.
Refer to the product data sheet for package details.

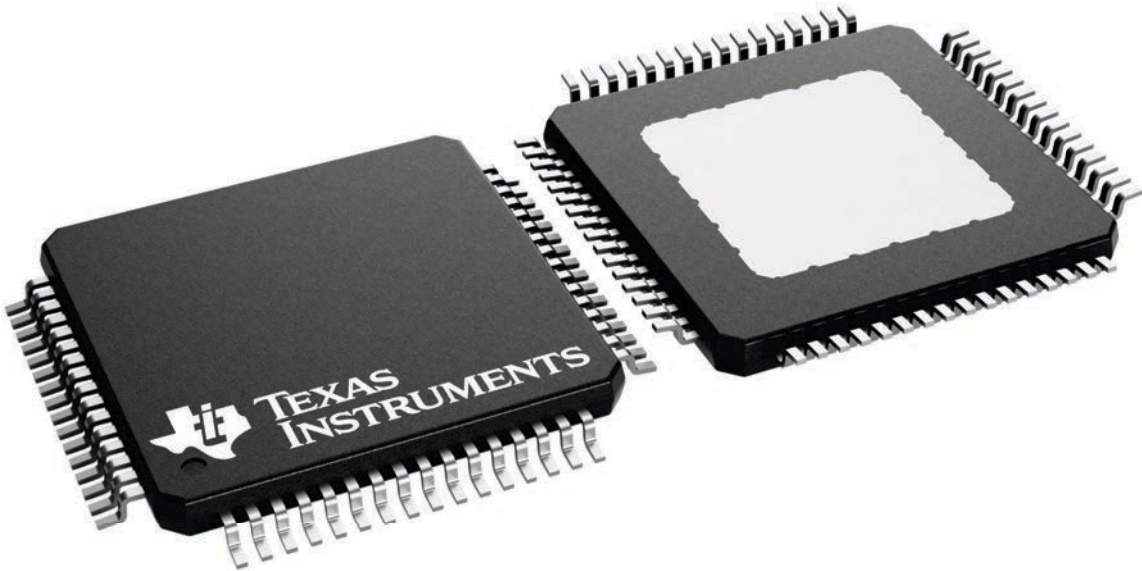

4226442/A

PACKAGE OUTLINE

PAP0064F

PowerPAD™ TQFP - 1.2 mm max height

PLASTIC QUAD FLATPACK

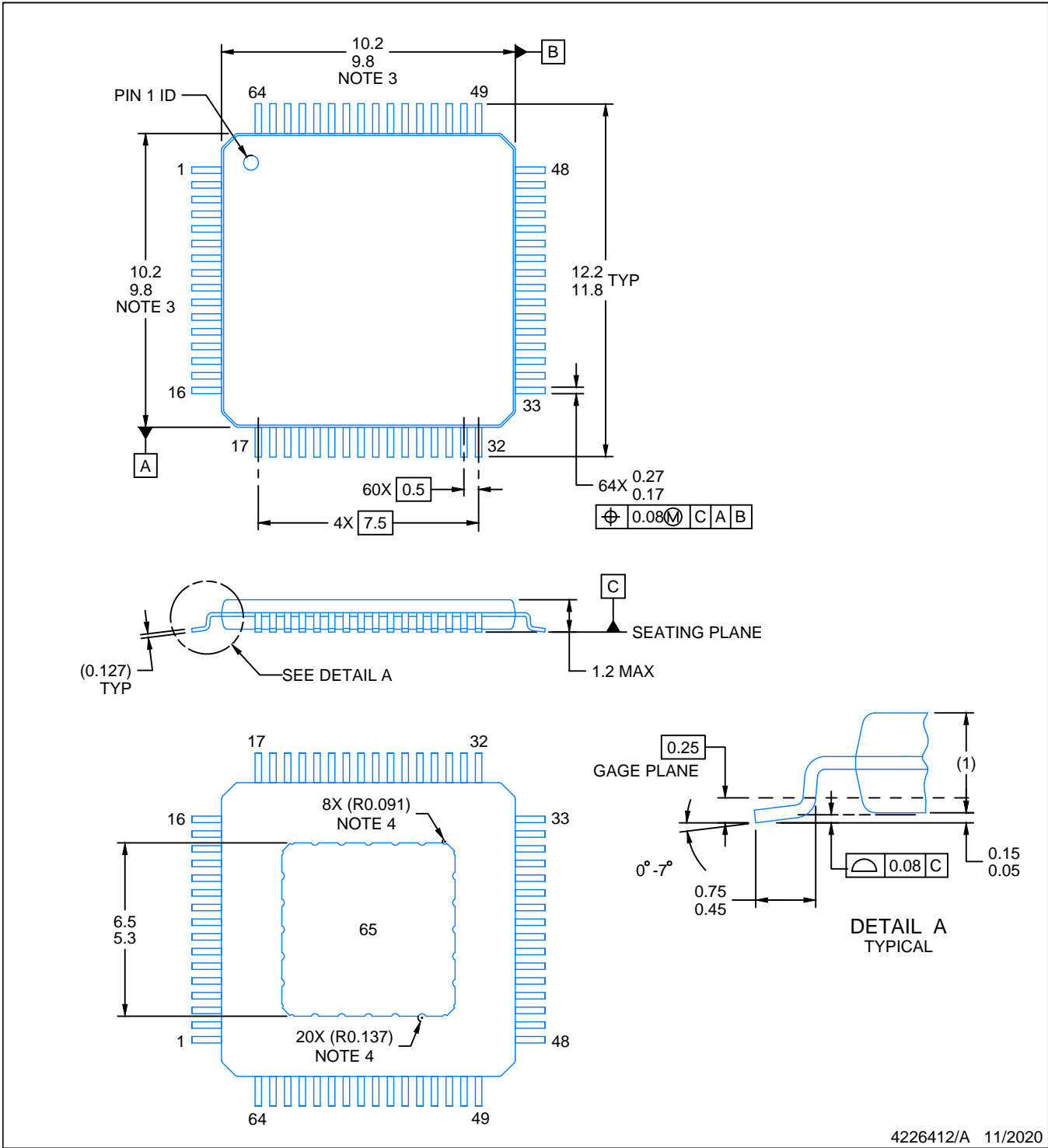

4226412/A 11/2020

NOTES:

PowerPAD is a trademark of Texas Instruments.

1. All linear dimensions are in millimeters. Any dimensions in parenthesis are for reference only. Dimensioning and tolerancing per ASME Y14.5M.
2. This drawing is subject to change without notice.
3. This dimension does not include mold flash, protrusions, or gate burrs.
4. Strap features may not be present.
5. Reference JEDEC registration MS-026.

EXAMPLE BOARD LAYOUT

PAP0064F

PowerPAD™ TQFP - 1.2 mm max height

PLASTIC QUAD FLATPACK

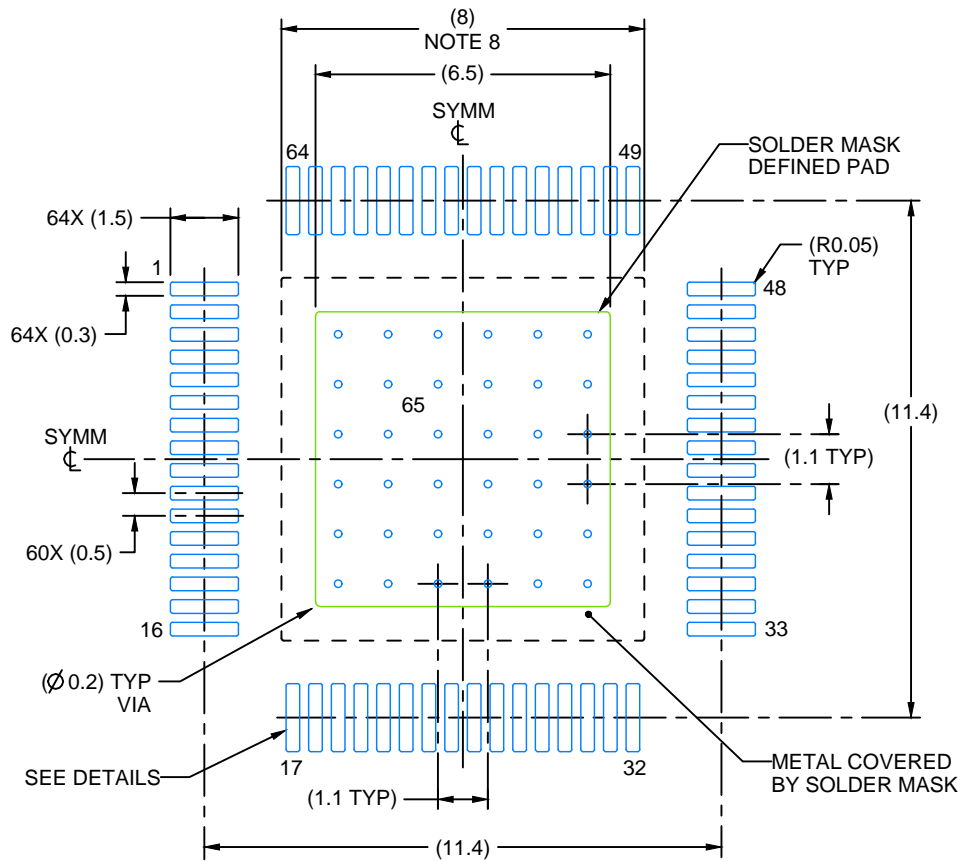

LAND PATTERN EXAMPLE
EXPOSED METAL SHOWN
SCALE:6X

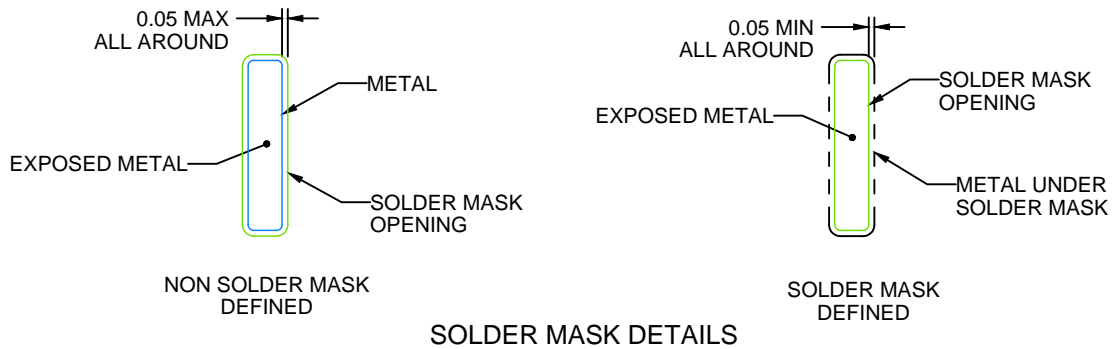

SOLDER MASK DETAILS

4226412/A 11/2020

NOTES: (continued)

6. Publication IPC-7351 may have alternate designs.
7. Solder mask tolerances between and around signal pads can vary based on board fabrication site.
8. This package is designed to be soldered to a thermal pad on the board. See technical brief, Powerpad thermally enhanced package, Texas Instruments Literature No. SLMA002 (www.ti.com/lit/slma002) and SLMA004 (www.ti.com/lit/slma004).
9. Vias are optional depending on application, refer to device data sheet. It is recommended that vias under paste be filled, plugged or tented.
10. Size of metal pad may vary due to creepage requirement.

EXAMPLE STENCIL DESIGN

PAP0064F

PowerPAD™ TQFP - 1.2 mm max height

PLASTIC QUAD FLATPACK

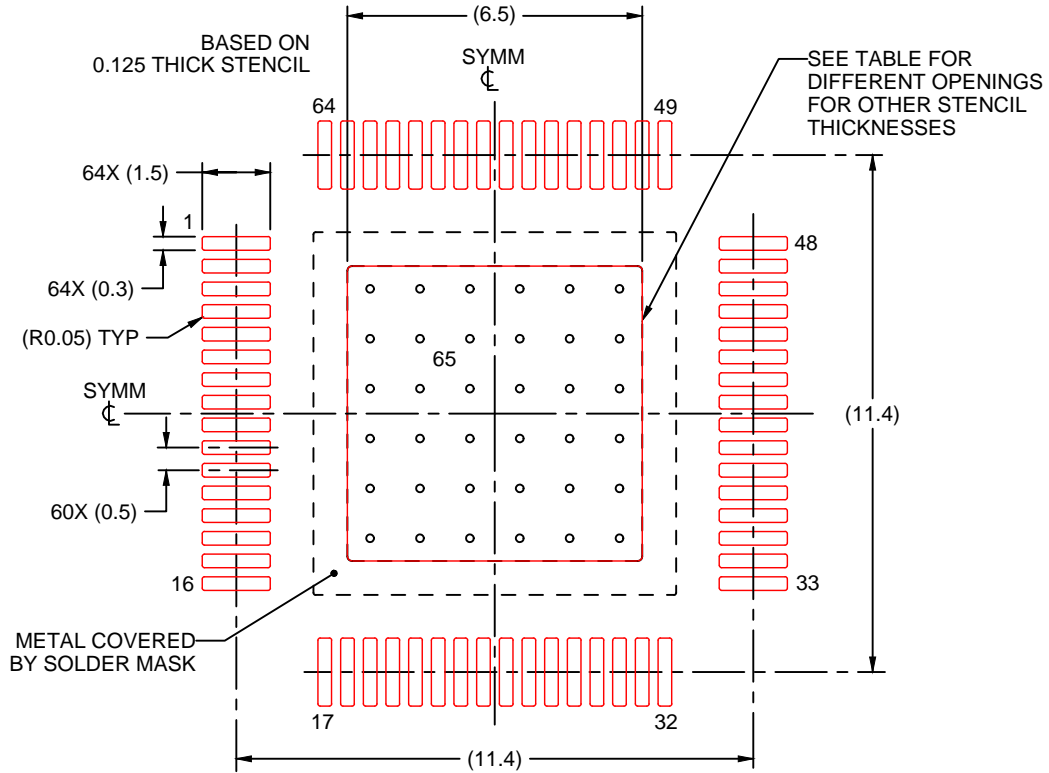

SOLDER PASTE EXAMPLE
 EXPOSED PAD
 100% PRINTED SOLDER COVERAGE BY AREA
 SCALE:6X

STENCIL THICKNESS	SOLDER STENCIL OPENING
0.1	7.27 X 7.27
0.125	6.5 X 6.5 (SHOWN)
0.15	5.93 X 5.93
0.175	5.49 X 5.49

4226412/A 11/2020

NOTES: (continued)

- 11. Laser cutting apertures with trapezoidal walls and rounded corners may offer better paste release. IPC-7525 may have alternate design recommendations.
- 12. Board assembly site may have different recommendations for stencil design.

重要なお知らせと免責事項

TI は、技術データと信頼性データ (データシートを含みます)、設計リソース (リファレンス・デザインを含みます)、アプリケーションや設計に関する各種アドバイス、Web ツール、安全性情報、その他のリソースを、欠陥が存在する可能性のある「現状のまま」提供しており、商品性および特定目的に対する適合性の黙示保証、第三者の知的財産権の非侵害保証を含むいかなる保証も、明示的または黙示的にかかわらず拒否します。

これらのリソースは、TI 製品を使用する設計の経験を積んだ開発者への提供を意図したものです。(1) お客様のアプリケーションに適した TI 製品の選定、(2) お客様のアプリケーションの設計、検証、試験、(3) お客様のアプリケーションに該当する各種規格や、その他のあらゆる安全性、セキュリティ、規制、または他の要件への確実な適合に関する責任を、お客様のみが単独で負うものとし、

上記の各種リソースは、予告なく変更される可能性があります。これらのリソースは、リソースで説明されている TI 製品を使用するアプリケーションの開発の目的でのみ、TI はその使用をお客様に許諾します。これらのリソースに関して、他の目的で複製することや掲載することは禁止されています。TI や第三者の知的財産権のライセンスが付与されている訳ではありません。お客様は、これらのリソースを自身で使用した結果発生するあらゆる申し立て、損害、費用、損失、責任について、TI およびその代理人を完全に補償するものとし、TI は一切の責任を拒否します。

TI の製品は、[TI の販売条件](#)、または [ti.com](#) やかかる TI 製品の関連資料などのいずれかを通じて提供する適用可能な条項の下で提供されています。TI がこれらのリソースを提供することは、適用される TI の保証または他の保証の放棄の拡大や変更を意味するものではありません。

お客様がいかなる追加条項または代替条項を提案した場合でも、TI はそれらに異議を唱え、拒否します。

郵送先住所 : Texas Instruments, Post Office Box 655303, Dallas, Texas 75265
Copyright © 2024, Texas Instruments Incorporated