

Point-of-Load Solutions for Data Center Applications Implementing VR13.HC V_{CCIN} Specification



Richard Nowakowski

ABSTRACT

Data centers are crucial for business continuity and reliable communications. Texas Instruments (TI) provides performance power management solutions, enabling high availability and efficiency when powering processors for data centers and rack servers. Advanced processors and platforms, such as the Intel® Whitley and Cedar Island platforms, need point-of-load solutions for memory, low-power CPU rails, and 3.3-V and 5-V rail requirements from a 12-V nominal input bus. This document intends to highlight DC/DC converters and describe their features addressing performance processor power requirements. For specific information about Intel processors and their power requirements, log on to the Intel Resource and Design Center. Contact TI for information about multiphase controllers and power stages designed specifically for the VR13.HC V_{CCIN} specification of Whitley and Cedar Island platforms.

Table of Contents

1 Suggested DC/DC Converters.....	2
2 Voltage Regulation Accuracy.....	3
3 Load Transient Response.....	4
4 High Efficiency and Thermal Performance.....	6
5 Linear Regulator with Adjustable Soft-Start.....	7
6 Conclusion.....	8
7 Additional Resources.....	8
8 Revision History.....	9

List of Figures

Figure 2-1. Remote Sense Without Feedback Resistors.....	3
Figure 2-2. Remote Sense With Feedback Resistors.....	3
Figure 3-1. Load Transient Response of a D-CAP3 Converter.....	4
Figure 3-2. Asynchronous Pulse Injection and Body Braking.....	5
Figure 4-1. SOA Curve for TPS543C20A.....	6
Figure 4-2. Power Loss Curves for TPS543C20A.....	6
Figure 5-1. TPS74801 Start-up Waveforms.....	7

List of Tables

Table 1-1. Suggested Point-of-Load Converters.....	2
Table 2-1. Feedback Voltage Regulation of the TPS548A28.....	3

Trademarks

D-CAP3™ is a trademark of Texas Instruments.
Intel® is a registered trademark of Intel Corporation.
All trademarks are the property of their respective owners.

1 Suggested DC/DC Converters

Table 1-1 highlights the latest point-of-load DC/DC converters with integrated FETs that are applicable to Whitley and Cedar Island applications; however, they are designed to accommodate the requirements for a wide range of markets. These devices are designed to achieve fast transient response, high efficiency, good thermal performance, and high output voltage accuracy. Notice that different control architectures are suggested in the chart. Fixed-frequency control architectures provide a predictable switching frequency and can be synchronized to an external clock. Current mode and voltage mode control are desirable in noise-sensitive applications that use data converters and high-speed analog circuits. On the other hand, devices implementing constant on-time control deliver a faster transient response than voltage or current mode control to quickly changing loads, since there is no internal clock to control the switching frequency. Several devices feature PMBus or I²C with Serial Voltage Identification (SVID), adaptive voltage scaling and margining. Devices integrating PMBus or I²C with telemetry report voltage, current, and temperature information to a host.

Table 1-1. Suggested Point-of-Load Converters

I _{OUT} RANGE	DEVICE (CONSTANT ON-TIME CONTROL)	DEVICE (FIXED FREQUENCY CONTROL)	PMBus / I ² C W/O TELEMETRY	PMBus / I ² C WITH TELEMETRY
DC/DC CONVERTERS WITH INTEGRATED MOSFETS				
≤ 2 A	TPS62148	TPS62912	N/A	N/A
2 A – 3 A	TPS62135	TPS62913	N/A	N/A
3 A – 6 A	TPS54J061	TPS543620	TPS542A50	TPS53820 (SVID)
6 A – 10 A	TPS54JA20	TPS54A24	TPS542A50	TPS546A24A
10 A – 15 A	TPS548A28	TPS542A52	TPS542A50	TPS546B24A
15 A – 20 A	TPS548B28	TPS543B20	TPS549B22	TPS546B24A
20 A – 25 A	TPS548B22	TPS543B20	TPS549B22	TPS546D24A
25 A – 40 A	TPS548D22	TPS543C20A	TPS549D22	TPS546D24A
DDR Memory Active Bus Termination				
≤ 2 A	TPS51200	Source / Sink Linear Regulator with Tracking		
2 A – 6 A	TPS53317A	DC/DC Converter with Tracking		
Low Drop Out Regulator				
1.5 A	TPS74801	Linear Regulator		

2 Voltage Regulation Accuracy

As the semiconductor process technology advances, processors require tighter voltage accuracy and lower operating voltages. The processor data sheet specifies the voltage tolerance as either a percentage or as a value in mV, which includes DC, AC and ripple variations over the entire operating temperature range. Designers also consider the tolerance of the resistor divider used by the DC/DC converter, the routing and trace losses of the circuit board, and the variations of the application, like the input voltage variations, temperature swings, and fast changes in the load.

Check the feedback voltage accuracy of the DC/DC converter in the data sheet rather than the front page. [Table 2-1](#) shows the regulated feedback voltage, or the internal voltage reference specification of the TPS548A28, which is a 2.7 V to 16 V, 15 A converter, and shows that the reference accuracy is ± 6 mV or $\pm 1\%$ over the full temperature range. The total output voltage accuracy is improved by choosing tighter tolerance resistors. If more headroom is needed, designers can choose 0.1% or 0.5% resistors, even though they may cost a little bit more. The additional headroom allows a total $\pm 3\%$ or $\pm 5\%$ output voltage variation to be met with less bulk and bypass capacitance.¹

Table 2-1. Feedback Voltage Regulation of the TPS548A28

PARAMETER	TEST CONDITION	MINIMUM	TYPICAL	MAXIMUM	UNIT
Internal Voltage Reference	$T_J = -40^\circ\text{C}$ to 125°C , $V_{CC} = 3\text{ V}$	594	600	606	mV
	$T_J = 0^\circ\text{C}$ to 85°C , $V_{CC} = 3\text{ V}$	597	600	603	mV

Layout constraints, connectors, and board density requirements often affect the total output voltage accuracy. A remote sense feature of a DC/DC converter compensates for voltage drops from long trace lines to accommodate processors needing high accuracy output voltage. This feature is especially useful when routing higher currents since the voltage drop can be a large portion of the overall DC error. [Figure 2-1](#) shows the TPS543B20 using the remote sense feature with voltage feedback resistors used to program the output voltage. [Figure 2-2](#) shows the TPS543B20 using the remote sense feature without voltage feedback resistors when the VSEL pin selects the reference voltage. The RSP and RSN pins are extremely high-impedance input terminals of a true differential remote sense amplifier.

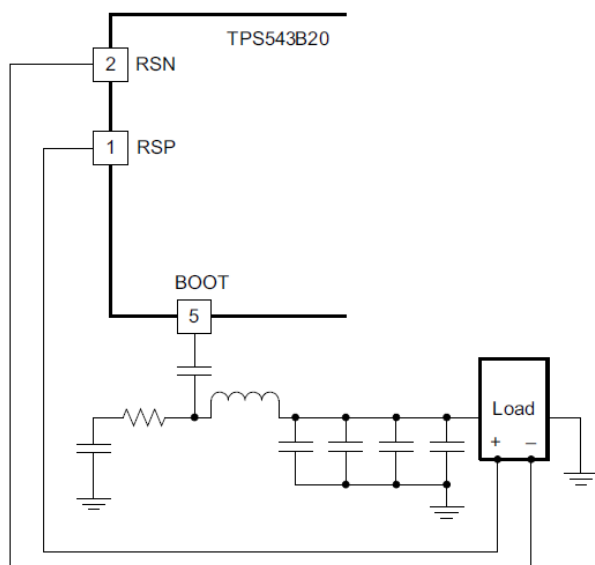

Figure 2-1. Remote Sense Without Feedback Resistors

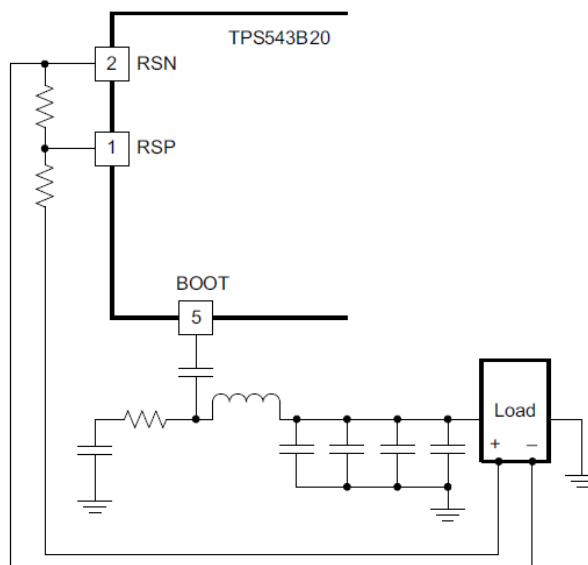

Figure 2-2. Remote Sense With Feedback Resistors

¹ [Power Tip #18](#): The output-voltage accuracy of the regulator may not be as bad as perceived.

3 Load Transient Response

Since the load profile can change dramatically in an enterprise rack server, it is important to consider AC transient performance. Choosing a DC/DC converter with a fast transient response using non-linear control techniques, such as constant on-time or D-CAP3™, allows a fast transient response with minimal output capacitance. A typical D-CAP3 converter design has three primary considerations for deciding the value of the output capacitance: transient (which includes load step and slew rate of the load step), output ripple, and stability. In applications where the load transient is stringent, the output capacitance is predominantly driven by the transient requirement. Today, a tight ripple requirement is becoming important in some high-end, high-performance application-specific integrated circuit (ASIC) and field-programmable gate array (FPGA) designs. The LC output power stage must be designed to meet the ripple criteria. For a D-CAP3-based design, there is a minimum capacitance requirement in terms of small signal stability. This requirement prevents subharmonic, multiple-pulsing behavior in all D-CAP modulators. Figure 3-1 shows how D-CAP3 control mode works in a load transient case. The [Calculating Output Capacitance to Meet Transient and Ripple Requirements of an Integrated POL Converter Design Based on D-CAPx™ Modulators](#) application report shows how to design the output filter for a 1-V output to accommodate a ± 10 mV ripple requirement and a ± 30 mV transient voltage deviation using the D-CAP3 control mode.

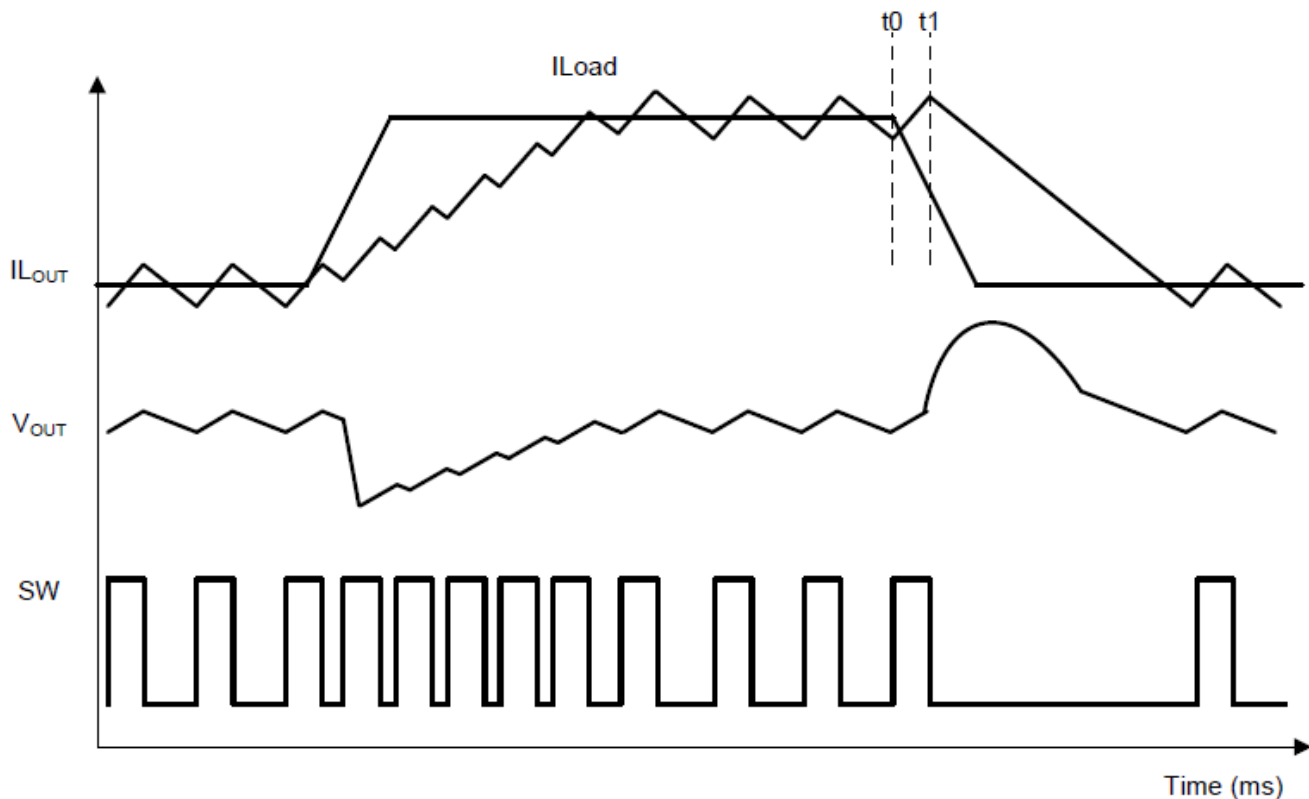

Figure 3-1. Load Transient Response of a D-CAP3 Converter

The TPS543C20A converter features a new control mode called Advanced Current Mode (ACM), which is an internally compensated emulated peak-current-mode control with a clock synchronizable, fixed-frequency modulator. The internal integrator and directly amplifying ramp tracking loop eliminates the need for external compensation over a wide range of frequencies. The TPS543C20A also features Asynchronous Pulse Injection (API) and body braking to improve transient performance by significantly reducing undershoot and overshoot, respectively, reducing the external capacitance requirement. When the API and body diode braking are activated, ACM delivers a similar transient performance as D-CAP3. Figure 3-2 shows examples of undershoot and overshoot reduction with API and body braking. ²

² [Comparing internally-compensated advanced current mode \(ACM\) with D-CAP3™ control](#)

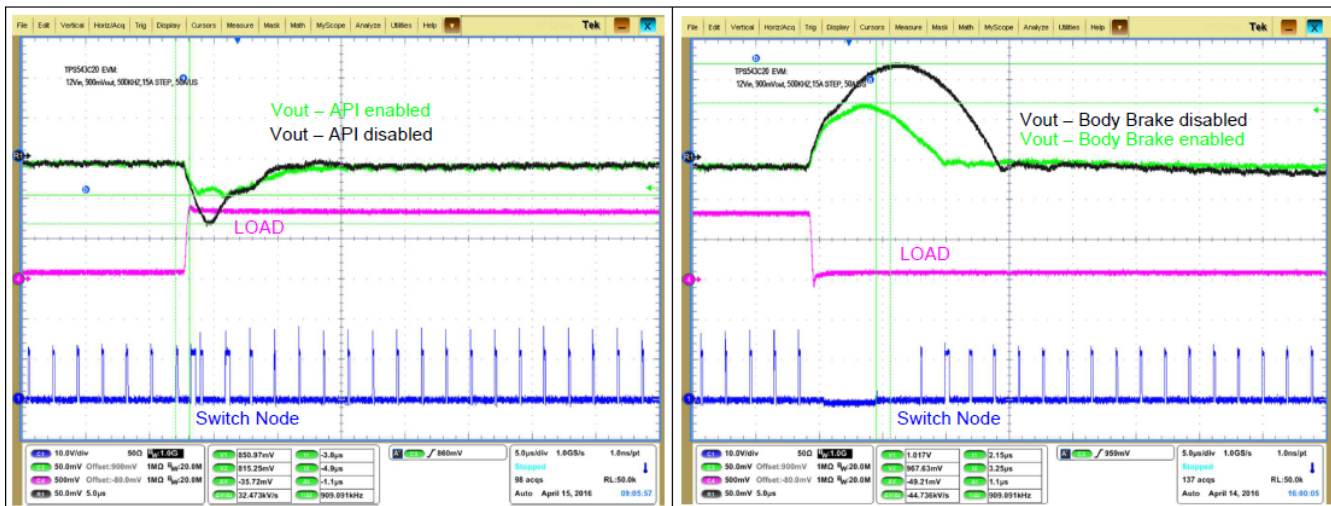

Figure 3-2. Asynchronous Pulse Injection and Body Braking

4 High Efficiency and Thermal Performance

Rack servers employ circuit boards with many PCB layers, depending on the form factor constraints. Since the rack server is designed to be used in tight spaces, consider the thermal environment and available airflow when selecting DC/DC converters. The ambient temperature inside a rack server is typically between 60°C and 70°C since forced airflow is usually available. Higher circuit board temperatures translate to lower reliability, and higher current DC/DC converters significantly contribute to the overall thermal budget. Figure 4-1 shows the safe operating curve and Figure 4-2 shows the power loss plot of TPS543C20A. The TPS543C20A DC/DC converter delivers 40 A and 1 V output with an ambient temperature of 75°C, without airflow. At 25 A and 1 V output, the entire solution dissipates less than 3 W, which translates to around 90% efficiency when switching at 500 kHz. The TPS543C20A measured junction-to-ambient thermal resistance is 12°C/W based on a 6-layer, 2-oz Cu per layer and a 2.75 inch by 3 inch board size, which demonstrates low thermal resistance. However, many thermal metrics exist for semiconductor and IC packages, which range from R θ JA to ψ JT. Often, designers misapply these thermal metrics when trying to estimate the junction temperatures in their systems. Ultimately, thermal performance depends on the circuit-board layout and using standard JEDEC-referenced thermal numbers.³

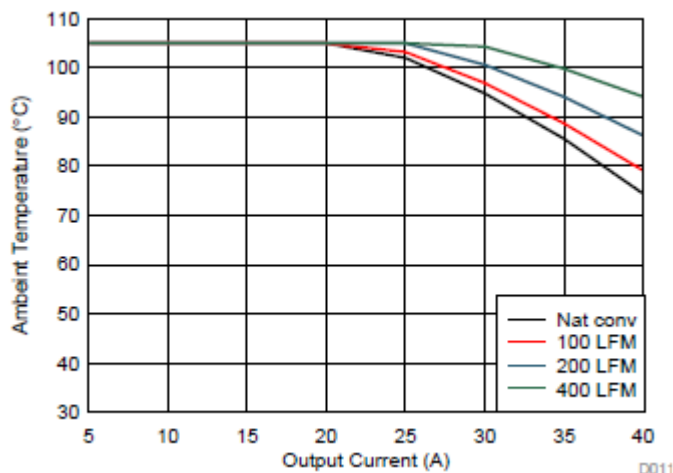

Figure 4-1. SOA Curve for TPS543C20A

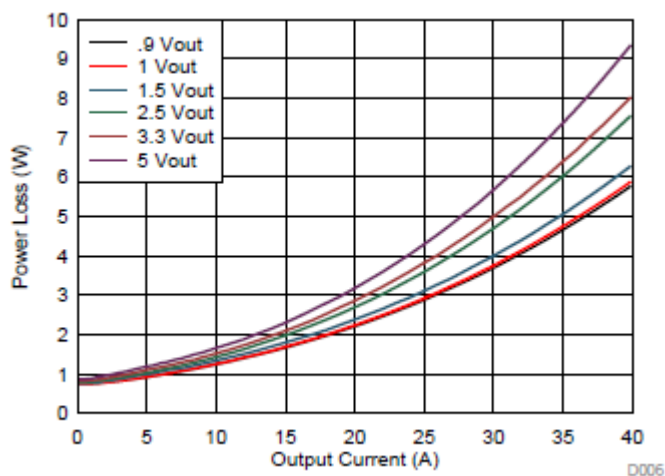

Figure 4-2. Power Loss Curves for TPS543C20A

³ [Understanding the thermal-resistance specification of DC/DC converters with integrated power MOSFETs](#)

5 Linear Regulator with Adjustable Soft-Start

For low current rails, a linear regulator with a user-programmable soft-start minimizes stress on the input power source by reducing the capacitive inrush current on start-up, especially from highly capacitive loads or with processors requiring many bypass capacitors. The TPS74801 adjustable linear regulator provides a monotonic (non-negative slope) soft-start that is well-suited for powering many different types of processors. Figure 5-1 illustrates the start-up waveform showing the start-up times varying over several soft start capacitor values.

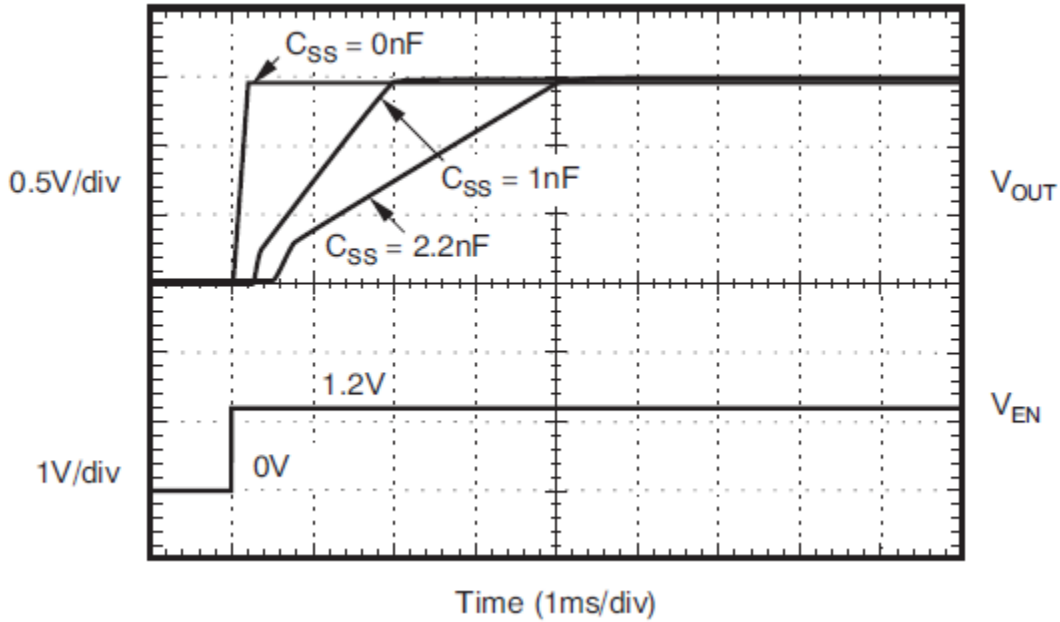

Figure 5-1. TPS74801 Start-up Waveforms

6 Conclusion

Performance processors, such as the Cedar Island and Whitley platforms in data centers, need DC/DC converters that offer improved output voltage accuracy, fast transient response, reduced external component count, high efficiency and excellent thermal performance. TI offers high performance point-of-load solutions to address these requirements.

7 Additional Resources

- Texas Instruments, [How to meet DC voltage accuracy and AC load transient specification?](#) training video.
- Texas Instruments, [Accuracy-Enhanced Ramp-Generation Design for D-CAP3 Modulation](#) Application Report.
- Texas Instruments, [Internally Compensated Advanced Current Mode](#) White Paper.
- Texas Instruments, [Control Mode Quick Reference Guide, Step-Down Non-Isolated DC/DC](#).
- Texas Instruments, [Rack Server](#).

8 Revision History

NOTE: Page numbers for previous revisions may differ from page numbers in the current version.

Changes from Revision * (March 2019) to Revision A (January 2021)	Page
• Added sample history element as an example.....	1
• Changed title from <i>Non-Isolated Point -of-Load Solutions for VR13.HC in Rack Server and Data Center App</i> to <i>Point-of-Load Solutions for Data Center Applications implementing VR13.HC V_{CCIN} Specification</i>	1

IMPORTANT NOTICE AND DISCLAIMER

TI PROVIDES TECHNICAL AND RELIABILITY DATA (INCLUDING DATASHEETS), DESIGN RESOURCES (INCLUDING REFERENCE DESIGNS), APPLICATION OR OTHER DESIGN ADVICE, WEB TOOLS, SAFETY INFORMATION, AND OTHER RESOURCES "AS IS" AND WITH ALL FAULTS, AND DISCLAIMS ALL WARRANTIES, EXPRESS AND IMPLIED, INCLUDING WITHOUT LIMITATION ANY IMPLIED WARRANTIES OF MERCHANTABILITY, FITNESS FOR A PARTICULAR PURPOSE OR NON-INFRINGEMENT OF THIRD PARTY INTELLECTUAL PROPERTY RIGHTS.

These resources are intended for skilled developers designing with TI products. You are solely responsible for (1) selecting the appropriate TI products for your application, (2) designing, validating and testing your application, and (3) ensuring your application meets applicable standards, and any other safety, security, or other requirements. These resources are subject to change without notice. TI grants you permission to use these resources only for development of an application that uses the TI products described in the resource. Other reproduction and display of these resources is prohibited. No license is granted to any other TI intellectual property right or to any third party intellectual property right. TI disclaims responsibility for, and you will fully indemnify TI and its representatives against, any claims, damages, costs, losses, and liabilities arising out of your use of these resources.

TI's products are provided subject to TI's Terms of Sale (<https://www.ti.com/legal/termsofsale.html>) or other applicable terms available either on [ti.com](https://www.ti.com) or provided in conjunction with such TI products. TI's provision of these resources does not expand or otherwise alter TI's applicable warranties or warranty disclaimers for TI products.

Mailing Address: Texas Instruments, Post Office Box 655303, Dallas, Texas 75265
Copyright © 2021, Texas Instruments Incorporated