

How to Implement an Isolated USB 2.0 High-Speed, Type-C® DRP

Anant Kamath
Systems Engineer

Manasa Gadiyar
Validation Engineer

Introduction

USB use has grown in industrial applications: for software uploads and configuration, diagnostics, maintenance, and connecting peripheral modules such as Wi-Fi® routers, display screens and human-machine interface modules. However, since USB's primary definition is as a consumer electronics interface, it is not inherently capable of handling the large noise disturbances, ground bounce and ground potential differences common in industrial applications. Also, in applications such as uninterrupted power supplies, controllers with the USB interface are on the high-voltage or "hot" side, needing protective isolation to the USB connector. Because of these reasons, isolating the USB interface has become necessary in a broad spectrum of applications, including factory automation, motor drives, medical equipment, e-meters, data concentrators, in-flight entertainment and gaming consoles.

The applications mentioned above often need the flexibility of connecting to a PC while acting as a peripheral (device), or to peripherals such as a Wi-Fi module or USB memory drive while acting as a host. In the past, system designers provided two different ports to support this functionality: one for the host and one for the peripheral - using two different USB isolators (also called isolated USB repeaters). This solution is expensive and takes up valuable board area. Instead, a

USB Type-C® connector can implement a dual-role port (DRP) – one port that supports both host and peripheral functionality. This article discusses how to implement an isolated USB 2.0 USB Type-C DRP.

Traditional host and peripheral implementations

Figure 1 shows the traditional implementation of isolated host and peripheral ports in industrial equipment. This implementation uses a USB isolator that has fixed upstream- and downstream-facing definitions. The downstream-facing (host) port powers a 5-V supply to the VBUS and includes 15-k Ω pulldown resistors, as specified by the USB standard. The upstream-facing (peripheral) port does not provide power to the USB VBUS. Once this port connects to a host, it detects the presence of VBUS and pulls up either DP (for full speed and high-speed operation) or DM (for low-speed operation) with a 1.5-k Ω resistor. Here, DP refers to DPLUS/D+ or the positive terminal of the USB data differential pair, and DM refers to DMINUS/D-. Since a DRP must expect to either pull up DP and DM in peripheral mode (upstream facing), or offer a 15-k Ω pulldown resistor to ground and expect an external 1.5-k Ω pullup on DP and DM in host mode (downstream facing), it is clear that traditional isolated USB repeaters that have fixed upstream- and downstream-facing sides cannot support a DRP.

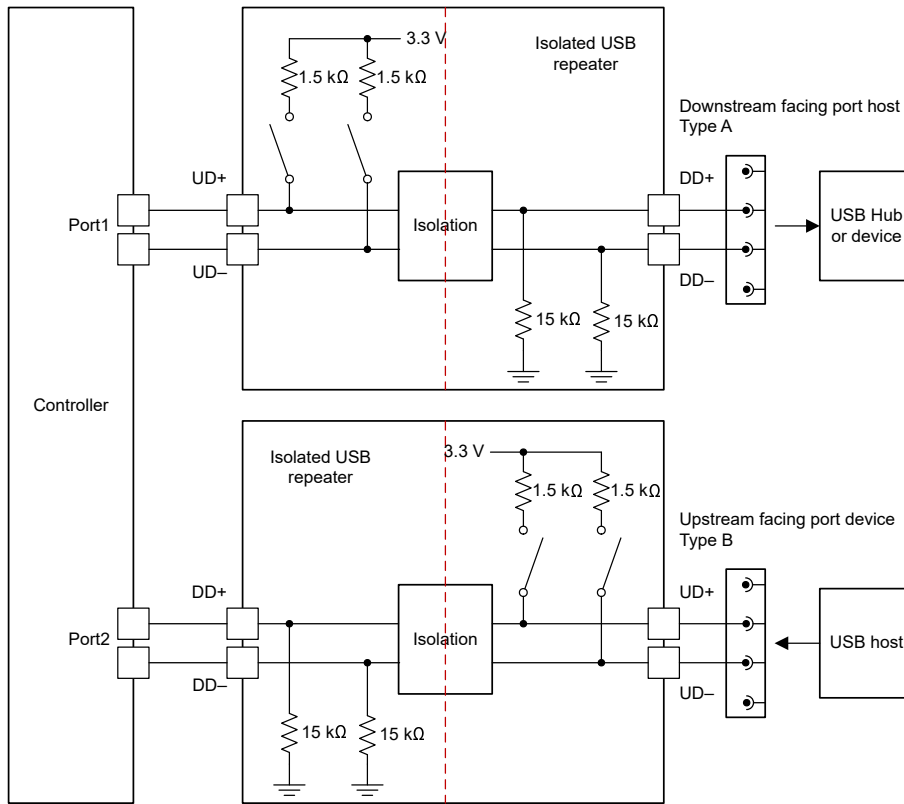

Figure 1. Traditional implementation offering dedicated host and peripheral ports with two isolated USB repeaters

USB Type-C DRP

In USB Type-C, the role of a port is determined by the state of the CC1 and CC2 pins. A peripheral port has pulldown resistors R_d from CC1 and CC2 to ground. A host port has pullup resistors R_p to VCC. This is shown in Figure 2. The values of R_d and R_p are governed by the USB Type-C standard. The host can use the value of R_p to advertise current available on the VBUS pin: 0.5 A, 1.5 A or 3 A.

A DRP periodically toggles CC1 and CC2 between R_p pullup to VCC and R_d pulldown to ground over a period of 50 ms to 100 ms, as defined in the USB Type-C standard. When connecting an external host to a DRP, the connection is detected during the interval of R_d pulldown and the DRP assumes a peripheral role (upstream-facing port). When connecting an external peripheral to a DRP, the connection is detected during the interval of R_p pullup, and the DRP assumes a host role (downstream-facing port).

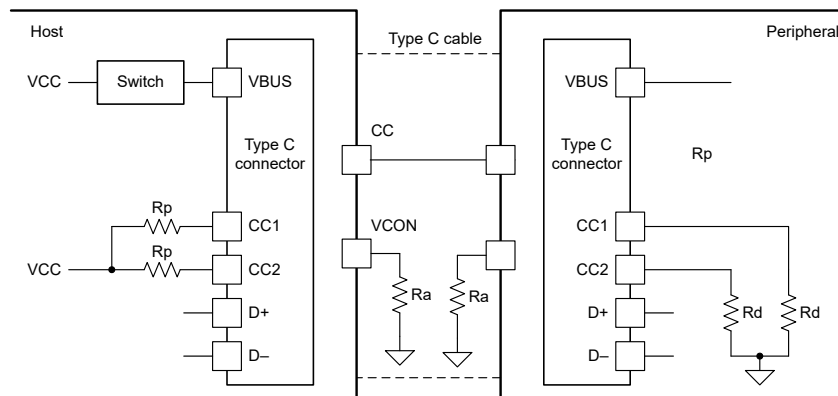

Figure 2. The state of the CC1 and CC2 pins determines host and peripheral roles in USB Type-C

Implementing an isolated USB Type-C DRP

Figure 3 shows the block diagram of a self-powered isolated USB Type-C DRP.

The first and main requirement is to have an isolated USB repeater that does not have fixed upstream- and downstream-facing sides, but allows those roles to change dynamically. In such a repeater, 15-k Ω pull-down resistors are included on both side 1 and side 2, and enabled at power up. After that, whichever side detects a 1.5-k Ω pullup on DP or DM assumes the role of the upstream-facing port and disables its 15-k Ω pull-down. The other port assumes the role of downstream-facing port and keeps its 15-k Ω pull-down resistors enabled.

The second component in **Figure 3** is a USB Type-C controller that can control the R_p and R_d resistors on the CC lines, interpret the state of the CC lines, and output

information on the host or peripheral role, current being advertised by host, and so on. Next, an isolated DC/DC converter provides power to the USB Type-C controller and to the USB isolator's secondary side. Lastly, a power switch on the VBUS turns on when the USB Type-C controller detects a peripheral connection; that is when the DRP has to assume a host or downstream-facing port role.

Most industrial applications are self-powered; in other words, they do not need to draw power from the VBUS when in peripheral mode. Therefore, **Figure 3** and **Figure 4** only show a unidirectional isolated power supply from the controller side to the connector side. Dual-role applications that need to draw power from the VBUS (for example, battery-powered applications) may require a bidirectional isolated DC/DC power supply, battery-charging circuitry and additional controls.

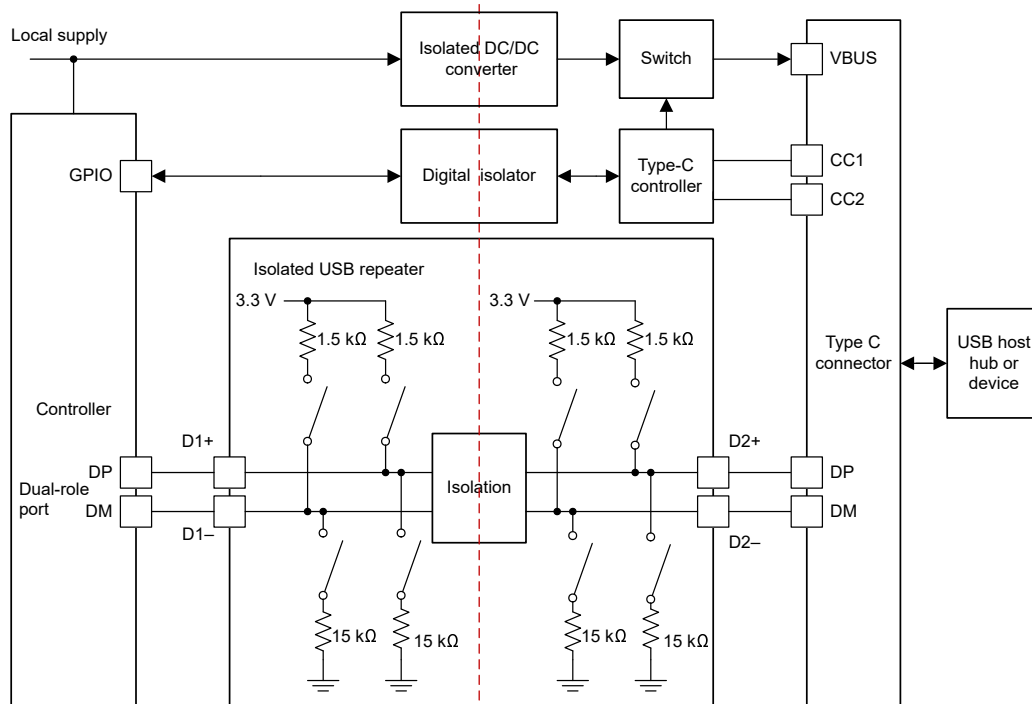

Figure 3. Block diagram of a self-powered isolated USB Type-C DRP

Implementation with actual components

Figure 4 shows the implementation of a self-powered isolated USB Type-C port with actual components. These include the Texas Instruments **ISOUSB211** isolated USB repeater, **SN6505** 5-W push-pull transformer driver,

TUSB320LA1 USB Type-C controller, **ISO7710** digital isolator, **TPS25910** VBUS switch and **ISO1640** isolated I2C isolator. The **ISOUSB211** supports automatic role detection, with both side 1 and side 2 capable of assuming upstream- and downstream-facing roles based

on which side detects a 1.5-kΩ pullup first. This feature is necessary for dual-role implementations.

The ID output of the **TUSB320LAI** indicates the negotiated role of the port. This ID information can control the power switch, and is also conveyed across the barrier to the controller using the **ISO7710** digital isolator.

It is possible to provide the VBUSOK1 output of the **ISOUSB211** as input to the VBUS detect pin of the controller. When acting as a peripheral or upstream-facing port, this pin lets the controller know when VBUS becomes available on the connector, after which the controller can proceed to enable its 1.5-kΩ pullup resistor.

The **ISO1640** isolated I2C isolator is optional, and allows access to additional configuration options in the **TUSB320LAI**, such as advertising up to 3-A VBUS current in host mode and configuring the DRP as try.SRC (where the DRP preferentially tries to establish itself as a downstream-facing port when connected to another DRP) or try.SNK (where the DRP preferentially tries to establish itself as an upstream-facing port when connected to another DRP). In the simplest implementations where the DRP only needs to advertise 0.5-A output current, and with no try.SRC or try.SNK features, the **ISO1640** device is not necessary.

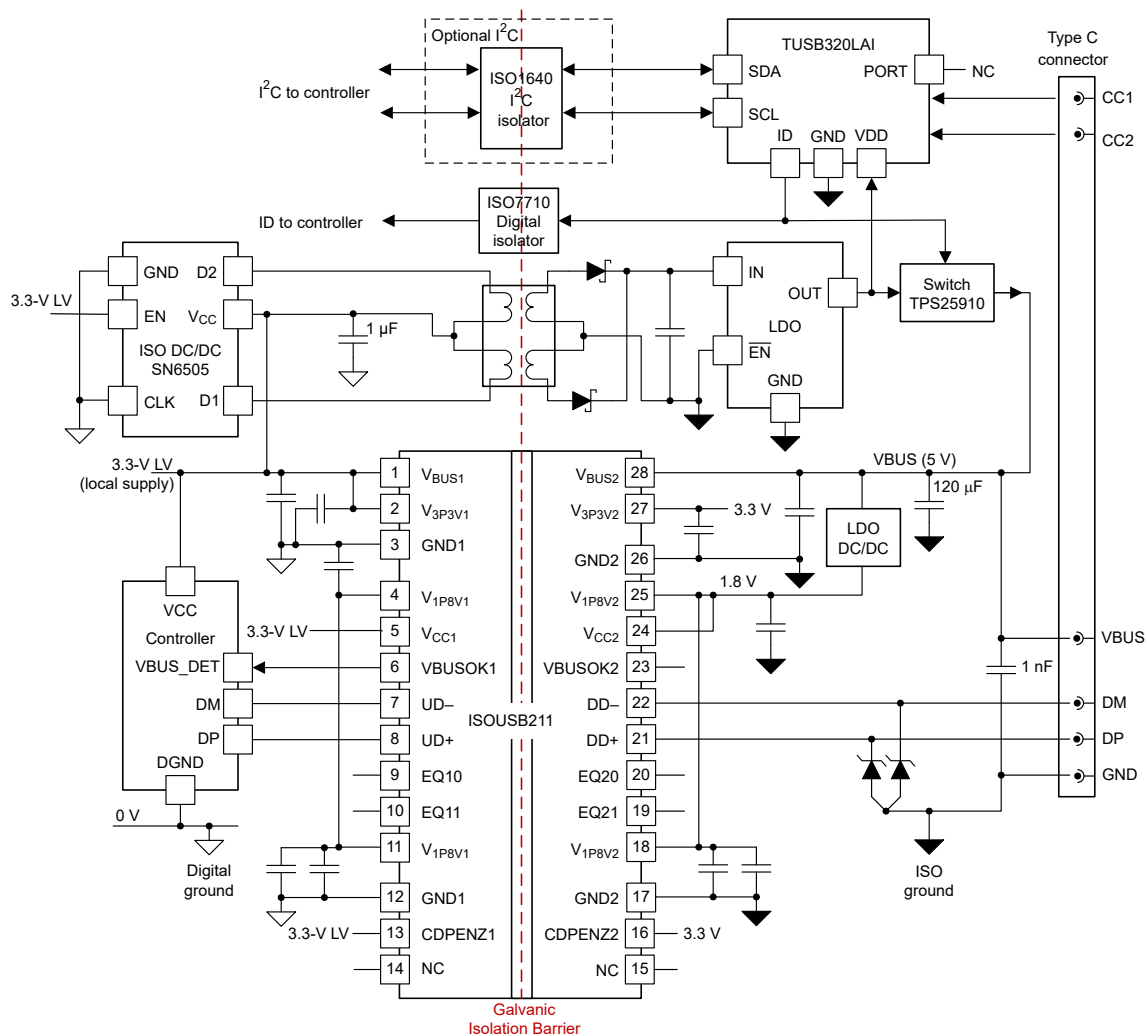

Figure 4. Isolated USB DRP implementation with the ISOUSB211 and TUSB320

Demonstration of DRP operation with the ISOUSB211 EVM

This section discusses the implementation of an isolated USB Type-C DRP by combining the **ISOUSB211** evaluation module (EVM) and **TUSB320-LA-EVM**.

In **Figure 5**, the **ISOUSB211** and **TUSB320LAI** together form a DRP. A standard peripheral-like mouse or USB flash drive interfaced with the **TUSB320-LA-EVM** configured as an upstream-facing port emulates a USB Type-C peripheral. The role of this second **TUSB320-LA-EVM** is only USB Type-A to USB Type-C conversion. Side 1 of the **ISOUSB211** EVM is powered by the VBUS output of the PC's USB port. Side 2 is powered by the isolated DC/DC converter present on the **ISOUSB211** EVM. The **TUSB320LAI** configured as a DRP detects the connection of a peripheral and provides a VBUS supply on the USB Type-C cable. The external peripheral (standard flash drive plus the **TUSB320-LA-EVM**) detects VBUS on the USB Type-C cable, and proceeds to connect.

The peripheral was able to enumerate, and data communication and transfer was successful.

The **TUSB320-LA-EVM** uses Schottky diodes in the supply path, which drop about 0.7 V. For proper operation in high-speed mode (when using a flash drive),

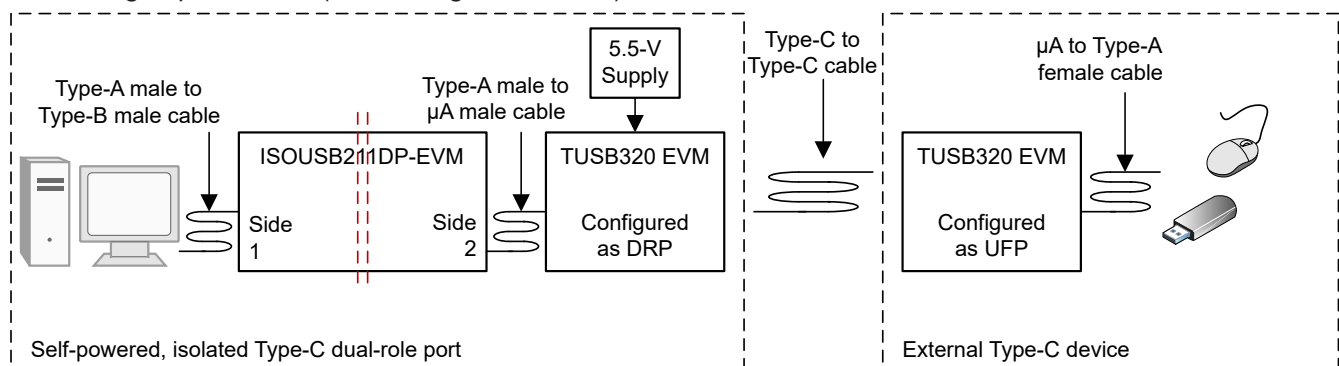

Figure 5. The **ISOUSB211** and **TUSB320** as a DRP connected to a USB Type-C device or peripheral

we connected an external power supply (5.5 V) to the DC_IN terminal of the **TUSB320-LA-EVM** to account for the 1.4-V voltage drop in the VBUS path across two Schottky diodes. This 5.5-V supply was not needed when using a mouse (low-speed operation).

In **Figure 6**, the **ISOUSB211** and **TUSB320LAI** together form a DRP. A standard host (any laptop or PC) interfaced with the **TUSB320-LA-EVM** configured as a downstream-facing port emulates a USB Type-C host. The role of this second **TUSB320-LA-EVM** is only USB Type-A to USB Type-C conversion. Side 1 of the **ISOUSB211** EVM is powered by an external 5-V power supply, and the isolated DC/DC converter on the **ISOUSB211** is disabled. The **TUSB320LAI** configured as a DRP detects the connection of a host and does not drive the USB Type-C VBUS. The external host (a standard laptop plus the **TUSB320** EVM) detects Rd pulldowns on CC pins and drives the VBUS supply. After VBUS is present on the USB Type-C connector, the peripheral connects.

The peripheral was able to enumerate and data transfer was successful.

An additional 5.5-V power supply was necessary for high-speed operation given the voltage drop across Schottky diodes on the **TUSB320-LA-EVM**, as explained earlier.

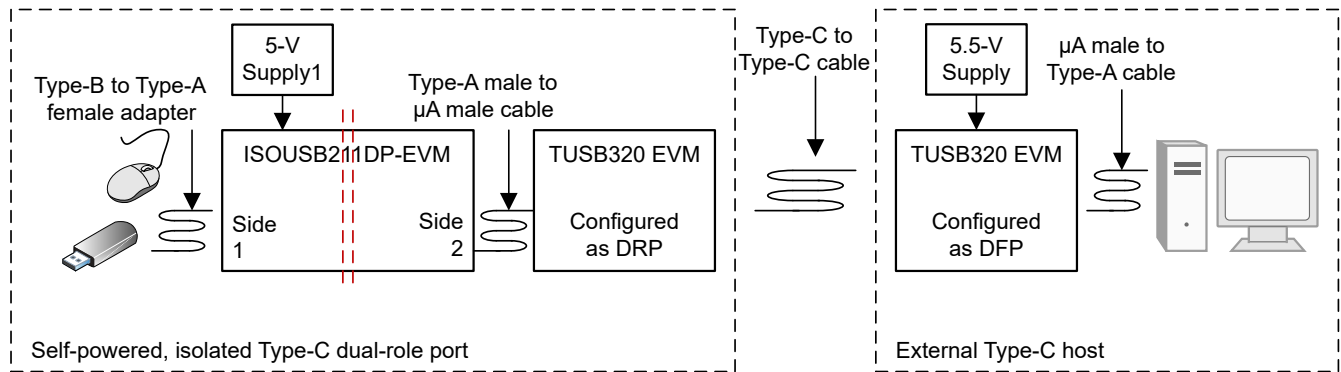

Figure 6. The ISOUUSB211 and TUSB320 as a DRP connected to a USB Type-C host

Conclusion

A USB Type-C DRP allows connection to either a host or a peripheral on the same connector. An isolated USB repeater that can automatically assign upstream- and downstream-facing directions based on detecting an external 1.5-k Ω pullup resistor enables the implementation of an isolated USB Type-C DRP. Such a solution saves on connectors, needs only one isolated USB repeater, saves board space, and brings flexibility to industrial applications.

Important Notice: The products and services of Texas Instruments Incorporated and its subsidiaries described herein are sold subject to TI's standard terms and conditions of sale. Customers are advised to obtain the most current and complete information about TI products and services before placing orders. TI assumes no liability for applications assistance, customer's applications or product designs, software performance, or infringement of patents. The publication of information regarding any other company's products or services does not constitute TI's approval, warranty or endorsement thereof.

Wi-Fi® is a registered trademark of Wi-Fi Alliance.
 USB Type-C® is a registered trademark of USB Implementers Forum.
 All trademarks are the property of their respective owners.

IMPORTANT NOTICE AND DISCLAIMER

TI PROVIDES TECHNICAL AND RELIABILITY DATA (INCLUDING DATA SHEETS), DESIGN RESOURCES (INCLUDING REFERENCE DESIGNS), APPLICATION OR OTHER DESIGN ADVICE, WEB TOOLS, SAFETY INFORMATION, AND OTHER RESOURCES "AS IS" AND WITH ALL FAULTS, AND DISCLAIMS ALL WARRANTIES, EXPRESS AND IMPLIED, INCLUDING WITHOUT LIMITATION ANY IMPLIED WARRANTIES OF MERCHANTABILITY, FITNESS FOR A PARTICULAR PURPOSE OR NON-INFRINGEMENT OF THIRD PARTY INTELLECTUAL PROPERTY RIGHTS.

These resources are intended for skilled developers designing with TI products. You are solely responsible for (1) selecting the appropriate TI products for your application, (2) designing, validating and testing your application, and (3) ensuring your application meets applicable standards, and any other safety, security, regulatory or other requirements.

These resources are subject to change without notice. TI grants you permission to use these resources only for development of an application that uses the TI products described in the resource. Other reproduction and display of these resources is prohibited. No license is granted to any other TI intellectual property right or to any third party intellectual property right. TI disclaims responsibility for, and you will fully indemnify TI and its representatives against, any claims, damages, costs, losses, and liabilities arising out of your use of these resources.

TI's products are provided subject to [TI's Terms of Sale](#) or other applicable terms available either on ti.com or provided in conjunction with such TI products. TI's provision of these resources does not expand or otherwise alter TI's applicable warranties or warranty disclaimers for TI products.

TI objects to and rejects any additional or different terms you may have proposed.

Mailing Address: Texas Instruments, Post Office Box 655303, Dallas, Texas 75265
Copyright © 2022, Texas Instruments Incorporated