

# CDx4HC(T)541 高速 CMOS ロジック、オクタール・バッファ/ライン・ドライバ、スリー・ステート

## 1 特長

- 'HC540, CD74HCT540: 反転型
- 'HC541, 'HCT541: 非反転型
- バッファ付き入力
- スリー・ステート出力
- バス・ライン駆動能力
- 伝搬遅延: 9 ns (標準値、 $V_{CC} = 5V$ 、 $C_L = 15pF$ 、 $T_A = 25^\circ C$ )
- ファンアウト (全温度範囲にわたって)
  - 標準出力: 10 個の LSTTL 負荷
  - バス・ドライバ出力: 15 個の LSTTL 負荷
- 広い動作温度範囲:  $-55^\circ C \sim 125^\circ C$
- 平衡な伝搬遅延と遷移時間
- LSTTL ロジック IC に比べて消費電力を大幅削減
- HC タイプ
  - 2V~6V で動作
  - 優れたノイズ耐性:  $V_{CC}$  に対して  $N_{IL} = 30\%$ 、 $N_{IH} = 30\%$  ( $V_{CC} = 5V$  時)
- HCT タイプ
  - 4.5V~5.5V で動作
  - LSTTL 入力ロジックと直接互換、 $V_{IL} = 0.8V$  (最大値)、 $V_{IH} = 2V$  (最小値)
  - CMOS 入力互換、 $V_{OL}$ 、 $V_{OH}$  で  $I_I \leq 1\mu A$

## 2 概要

'HC540 および CD74HCT540 は、15 の LSTTL 負荷を駆動できるスリー・ステート出力の反転型オクタール・バッファ/ライン・ドライバです。'HC541 および 'HCT541 は、15 の LSTTL 負荷を駆動できるスリー・ステート出力の非反転型オクタール・バッファ/ライン・ドライバです。出力イネーブル ( $\overline{OE1}$ ) および ( $\overline{OE2}$ ) によってスリー・ステート出力が制御されます。 $\overline{OE1}$  または  $\overline{OE2}$  のいずれかが High の場合、出力はハイ・インピーダンス状態になります。データを出力するには、 $\overline{OE1}$  と  $\overline{OE2}$  の両方を Low にする必要があります。

### パッケージ情報

部品番号	パッケージ <sup>(1)</sup>	本体サイズ (公称)
CD74HC540M	SOIC (20)	12.80mm × 7.50mm
CD74HC540E	PDIP (20)	25.40mm × 6.35mm
CD54HC540F3A	CDIP (20)	26.92mm × 6.92mm
CD74HC541M	SOIC (20)	12.80mm × 7.50mm
CD74HC541E	PDIP (20)	25.40mm × 6.35mm
CD54HC541F	CDIP (20)	26.92mm × 6.92mm
CD74HCT540M	SOIC (20)	12.80mm × 7.50mm
CD74HCT540E	PDIP (20)	25.40mm × 6.35mm
CD74HCT541M	SOIC (20)	12.80mm × 7.50mm
CD74HCT541E	PDIP (20)	25.40mm × 6.35mm
CD54HCT541F	CDIP (20)	26.92mm × 6.92mm
CD74HCT541PW	TSSOP (20)	6.50mm × 4.40mm

(1) 利用可能なパッケージについては、このデータシートの末尾にある注文情報を参照してください。

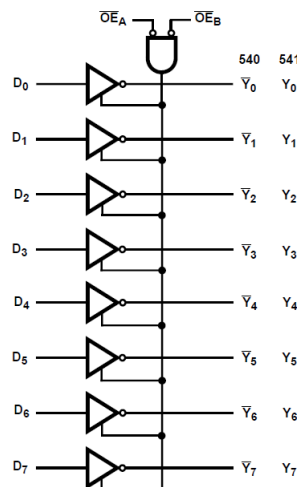

機能ダイアグラム



## Table of Contents

<b>1 特長</b> .....	1	7.2 Functional Block Diagram.....	9
<b>2 概要</b> .....	1	7.3 Device Functional Modes.....	9
<b>3 Revision History</b> .....	2	<b>8 Power Supply Recommendations</b> .....	10
<b>4 Pin Configuration and Functions</b> .....	3	<b>9 Layout</b> .....	10
<b>5 Specifications</b> .....	4	9.1 Layout Guidelines.....	10
5.1 Absolute Maximum Ratings.....	4	<b>10 Device and Documentation Support</b> .....	11
5.2 Recommended Operating Conditions.....	4	10.1 Receiving Notification of Documentation Updates..	11
5.3 Thermal Information.....	4	10.2 サポート・リソース.....	11
5.4 Electrical Characteristics.....	5	10.3 Trademarks.....	11
5.5 Switching Characteristics.....	6	10.4 Electrostatic Discharge Caution.....	11
<b>6 Parameter Measurement Information</b> .....	8	10.5 Glossary.....	11
<b>7 Detailed Description</b> .....	9	<b>11 Mechanical, Packaging, and Orderable Information</b> .....	11
7.1 Overview.....	9		

### 3 Revision History

資料番号末尾の英字は改訂を表しています。その改訂履歴は英語版に準じています。

<b>Changes from Revision D (January 2022) to Revision E (October 2022)</b>	<b>Page</b>
• Increased R $\theta$ JA for packages: DW (58 to 109.1); N (69 to 84.6); PW (83 to 131.8).....	4

<b>Changes from Revision C (July 2004) to Revision D (January 2022)</b>	<b>Page</b>
• 最新のデータシート規格を反映するように、文書全体の採番、書式設定、表、図、相互参照を更新.....	1



### 4 Pin Configuration and Functions

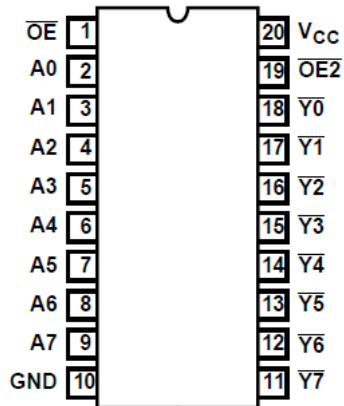

**HC540**  
J, N, or DW package  
20-Pin CDIP, PDIP, or SOIC  
Top View

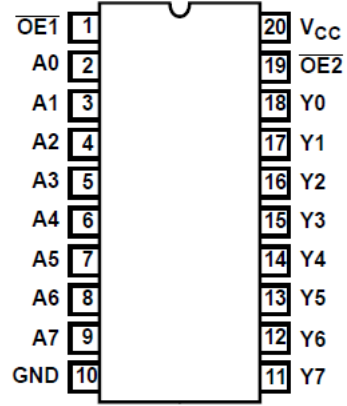

**HC541**  
J, N, DW, or PW  
20-Pin CDIP, PDIP, SOIC, or TSSOP  
Top View

## 5 Specifications

### 5.1 Absolute Maximum Ratings

over operating free-air temperature range (unless otherwise noted)<sup>(1)</sup>

		MIN	MAX	UNIT
V <sub>CC</sub>	Supply voltage	-0.5	7	V
I <sub>IK</sub>	Input diode current	For V <sub>I</sub> < -0.5 V or V <sub>I</sub> > V <sub>CC</sub> + 0.5 V		±20 mA
I <sub>OK</sub>	Output diode current	For V <sub>O</sub> < -0.5 V or V <sub>O</sub> > V <sub>CC</sub> + 0.5 V		±20 mA
I <sub>O</sub>	Drain current, per output	For -0.5 V < V <sub>O</sub> < V <sub>CC</sub> + 0.5 V		±35 mA
I <sub>O</sub>	Output source or sink current per output pin	For V <sub>O</sub> > -0.5 V or V <sub>O</sub> < V <sub>CC</sub> + 0.5 V		±25 mA
Continuous current through V <sub>CC</sub> or ground current				±50 mA
T <sub>J</sub>	Junction temperature			150 °C
T <sub>stg</sub>	Storage temperature range	-65	150	°C
Lead temperature (Soldering 10s) (SOIC - Lead Tips Only)				300 °C

- (1) Operation outside the *Absolute Maximum Ratings* may cause permanent device damage. Absolute maximum ratings do not imply functional operation of the device at these or any other conditions beyond those listed under *Recommended Operating Conditions*. If briefly operating outside the *Recommended Operating Conditions* but within the *Absolute Maximum Ratings*, the device may not sustain damage, but it may not be fully functional. Operating the device in this manner may affect device reliability, functionality, performance, and shorten the device lifetime.

### 5.2 Recommended Operating Conditions

		MIN	MAX	UNIT
T <sub>A</sub>	Temperature range	-55	125	°C
V <sub>CC</sub>	Supply voltage range	HC types	6	V
		HCT types	4.5	
V <sub>I</sub> , V <sub>O</sub>	Input or output voltage	0	V <sub>CC</sub>	V
	Input rise and fall time	2 V	1000	ns
		4.5 V	500	
		6 V	400	

### 5.3 Thermal Information

THERMAL METRIC		DW (SOIC)	N (PDIP)	PW (TSSOP)	UNIT
		20 PINS	20 PINS	20 PINS	
R <sub>θJA</sub>	Junction-to-ambient thermal resistance <sup>(1)</sup>	109.1	84.6	131.8	°C/W
R <sub>θJC(top)</sub>	Junction-to-case (top) thermal resistance	76	72.5	72.2	°C/W
R <sub>θJB</sub>	Junction-to-board thermal resistance	77.6	65.3	82.8	°C/W
ψ <sub>JT</sub>	Junction-to-top characterization parameter	51.5	55.3	21.5	°C/W
ψ <sub>JB</sub>	Junction-to-board characterization parameter	77.1	65.2	82.4	°C/W
R <sub>θJC(bot)</sub>	Junction-to-case (bottom) thermal resistance	N/A	N/A	N/A	°C/W

- (1) For more information about traditional and new thermal metrics, see the [Semiconductor and IC package thermal metrics](#) application report.



### 5.4 Electrical Characteristics

PARAMETER		TEST CONDITIONS <sup>(2)</sup>	V <sub>CC</sub> (V)	25°C			-40°C to 85°C		-55°C to 125°C		UNIT
				MIN	TYP	MAX	MIN	MAX	MIN	MAX	
<b>HC TYPES</b>											
V <sub>IH</sub>	High level input voltage		2	1.5		1.5		1.5		V	
			4.5	3.15		3.15		3.15			
			6	4.2		4.2		4.2			
V <sub>IL</sub>	Low level input voltage		2		0.5		0.5		0.5	V	
			4.5		1.35		1.35		1.35		
			6		1.8		1.8		1.8		
V <sub>OH</sub>	High level output voltage CMOS loads	I <sub>OH</sub> = - 20 μA	2	1.9		1.9		1.9		V	
		I <sub>OH</sub> = - 20 μA	4.5	4.4		4.4		4.4			
		I <sub>OH</sub> = - 20 μA	6	5.9		5.9		5.9			
	High level output voltage TTL loads	I <sub>OH</sub> = - 6 mA	4.5	3.98		3.84		3.7			
		I <sub>OH</sub> = - 7.8 mA	6	5.48		5.34		5.2			
V <sub>OL</sub>	Low level output voltage CMOS loads	I <sub>OL</sub> = 20 μA	2		0.1		0.1		0.1	V	
		I <sub>OL</sub> = 20 μA	4.5		0.1		0.1		0.1		
		I <sub>OL</sub> = 20 μA	6		0.1		0.1		0.1		
	Low level output voltage TTL loads	I <sub>OL</sub> = 6 mA	4.5		0.26		0.33		0.4		
		I <sub>OL</sub> = 7.8 mA	6		0.26		0.33		0.4		
I <sub>I</sub>	Input leakage current	V <sub>I</sub> = V <sub>CC</sub> or GND	6		±0.1		±1		±1	μA	
I <sub>CC</sub>	Quiescent device current	V <sub>I</sub> = V <sub>CC</sub> or GND	6		8		80		160	μA	
I <sub>OZ</sub>	Three-state leakage current	V <sub>O</sub> = V <sub>CC</sub> or GND	6		±0.5		±5.0		±10	μA	
<b>HCT TYPES</b>											
V <sub>IH</sub>	High level input voltage		4.5 to 5.5	2		2		2		V	
V <sub>IL</sub>	Low level input voltage		4.5 to 5.5		0.8		0.8		0.8	V	
V <sub>OH</sub>	High level output voltage CMOS loads	V <sub>OH</sub> = - 20 μA	4.5	4.4		4.4		4.4		V	
	High level output voltage TTL loads	V <sub>OH</sub> = - 6 mA	4.5	3.98		3.84		3.7			
V <sub>OL</sub>	Low level output voltage CMOS loads	V <sub>OL</sub> = 20 μA	4.5		0.1		0.1		0.1	V	
	Low level output voltage TTL loads	V <sub>OL</sub> = 6 mA	4.5		0.26		0.33		0.4		
I <sub>I</sub>	Input leakage current	V <sub>I</sub> = V <sub>CC</sub> and GND	5.5		±0.1		±1		±1	μA	
I <sub>CC</sub>	Quiescent device current	V <sub>I</sub> = V <sub>CC</sub> and GND	5.5		8		80		160	μA	
I <sub>OZ</sub>	Three-state leakage current	V <sub>O</sub> = V <sub>CC</sub> or GND	5.5		±0.5		±5.0		±10	μA	

## 5.4 Electrical Characteristics (continued)

PARAMETER		TEST CONDITIONS <sup>(2)</sup>	V <sub>CC</sub> (V)	25°C			–40°C to 85°C		–55°C to 125°C		UNIT
				MIN	TYP	MAX	MIN	MAX	MIN	MAX	
ΔI <sub>CC</sub> <sup>(1)</sup>	HCT540 Additional quiescent device current per input pin	A0 - A7 inputs held at V <sub>CC</sub> -2.1	4.5 to 5.5		100	360		450		490	μA
		$\overline{OE}2$ input held at V <sub>CC</sub> -2.1	4.5 to 5.5		100	270		337.5		367.5	μA
		$\overline{OE}1$ input held at V <sub>CC</sub> -2.1	4.5 to 5.5		100	414		517.5		563.5	μA
	HCT541 Additional quiescent device current per input pin	A0 - A7 inputs held at V <sub>CC</sub> -2.1	4.5 to 5.5		100	144		180		196	μA
		$\overline{OE}2$ input held at V <sub>CC</sub> -2.1	4.5 to 5.5		100	270		337.5		367.5	μA
		$\overline{OE}1$ input held at V <sub>CC</sub> -2.1	4.5 to 5.5		100	414		517.5		563.5	μA

(1) For dual-supply systems theoretical worst case (V<sub>I</sub> = 2.4 V, V<sub>CC</sub> = 5.5 V) specification is 1.8mA.

(2) V<sub>I</sub> = V<sub>IH</sub> or V<sub>OL</sub>, unless otherwise noted.

## 5.5 Switching Characteristics

PARAMETER		TEST CONDITIONS	V <sub>CC</sub> (V)	25°C			–40°C to 85°C		–55°C to 125°C		UNIT
				MIN	TYP	MAX	MIN	MAX	MIN	MAX	
<b>HC TYPES</b>											
t <sub>PLH</sub> , t <sub>PHL</sub>	Propagation delay Data to outputs (540)	C <sub>L</sub> = 50 pF	2		110		140		165	ns	
			4.5		22		28	33			
		C <sub>L</sub> = 15 pF	5		9					ns	
			6		19		24	28			
t <sub>PLZ</sub> , t <sub>PHZ</sub>	Data to outputs (541)	C <sub>L</sub> = 50 pF	2		115		145		175	ns	
			4.5		23		29	35			
		C <sub>L</sub> = 15 pF	5		9					ns	
			6		20		25	30			
t <sub>PLZ</sub> , t <sub>PHZ</sub>	Output enable and disable to outputs (540)	C <sub>L</sub> = 50 pF	2		160		200		240	ns	
			4.5		32		40	48			
		C <sub>L</sub> = 15 pF	5		13					ns	
			6		27		34	41			
t <sub>PLZ</sub> , t <sub>PHZ</sub>	Output enable and disable to outputs (541)	C <sub>L</sub> = 50 pF	2		160		200		240	ns	
			4.5		32		40	48			
		C <sub>L</sub> = 15 pF	5		14					ns	
			6		23		29	35			
t <sub>THL</sub> , t <sub>TLH</sub>	Output transition time	C <sub>L</sub> = 50 pF	2		60		75		90	ns	
			4.5		12		15	18			
			6		10		13	15			
C <sub>I</sub>	Input capacitance	C <sub>L</sub> = 50 pF		10	10		10	10	pF		
C <sub>O</sub>	Three-state output capacitance			20	20		20	20	pF		
C <sub>PD</sub>	Power dissipation capacitance <sup>(1) (2)</sup> (540)	C <sub>L</sub> = 15 pF	5	50					pF		
C <sub>PD</sub>	Power dissipation capacitance <sup>(1) (2)</sup> (541)	C <sub>L</sub> = 15 pF	5	48					pF		
<b>HCT TYPES</b>											
t <sub>PHL</sub> , t <sub>PLH</sub>	Propagation delay	C <sub>L</sub> = 50 pF	4.5		24		30		36	ns	
	Data to outputs (540)	C <sub>L</sub> = 15 pF	5		9						

**5.5 Switching Characteristics (continued)**

PARAMETER		TEST CONDITIONS	V <sub>CC</sub> (V)	25°C			–40°C to 85°C		–55°C to 125°C		UNIT
				MIN	TYP	MAX	MIN	MAX	MIN	MAX	
t <sub>PHL</sub> , t <sub>PLH</sub>	Data to outputs (541)	C <sub>L</sub> = 50 pF	4.5		28		35		42	ns	
		C <sub>L</sub> = 15 pF	5		11						
t <sub>PLZ</sub> , t <sub>PHZ</sub>	Output enable and disable to outputs (540, 541)	C <sub>L</sub> = 50 pF	4.5		35		44		53	ns	
		C <sub>L</sub> = 15 pF	5		14						
t <sub>TLH</sub> , t <sub>THL</sub>	Output transition time	C <sub>L</sub> = 50 pF	4.5		12		15		18	ns	
C <sub>I</sub>	Input capacitance	C <sub>L</sub> = 50 pF		10	10		10		10	pF	
C <sub>O</sub>	Three-state output capacitance			20	20		20		20	pF	
C <sub>PD</sub>	Power dissipation capacitance <sup>(1) (2)</sup> (540, 541)	C <sub>L</sub> = 15 pF	5		55					pF	

(1) C<sub>PD</sub> is used to determine the dynamic power consumption, per channel.

(2) P<sub>D</sub> = V<sub>CC</sub><sup>2</sup>f<sub>i</sub>(C<sub>PD</sub> + C<sub>L</sub>) where f<sub>i</sub> = input frequency, C<sub>L</sub> = output load capacitance, V<sub>CC</sub> = supply voltage.

## 6 Parameter Measurement Information

$t_{pd}$  is the maximum between  $t_{PLH}$  and  $t_{PHL}$

$t_t$  is the maximum between  $t_{TLH}$  and  $t_{THL}$

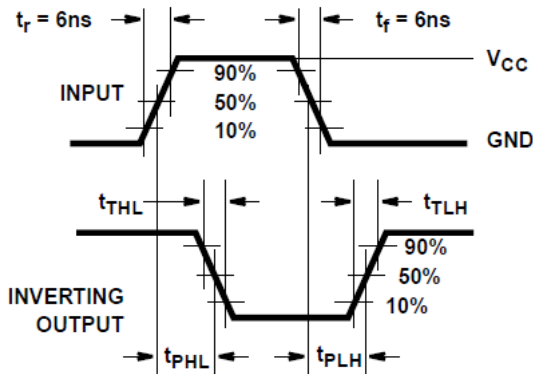

6-1. HC Transition Times and Propagation Delay Times, Combination Logic

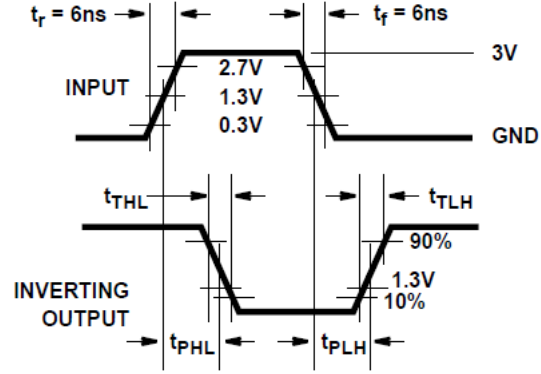

6-2. HCT Transition Times and Propagation Delay Times, combination Logic

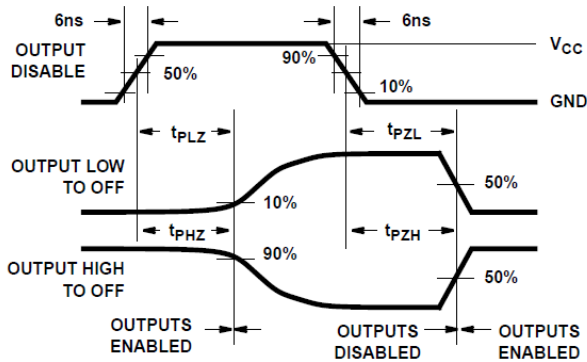

6-3. HC Three-State Propagation Delay Waveform

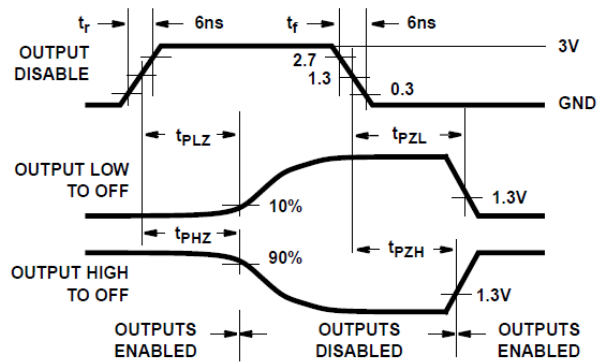

6-4. HCT Three-State Propagation Delay Waveform

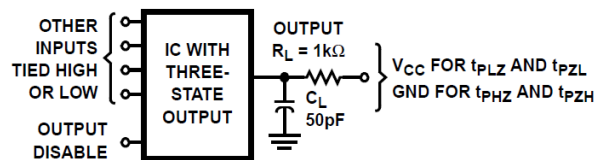

- A. Open drain waveforms  $t_{PLZ}$  and  $t_{PZL}$  are the same as those for three-state shown on the left. The test circuit is Output  $R_L = 1k\Omega$  to  $V_{CC}$ ,  $C_L = 50$  pF.

6-5. HC and HCT Three-State Propagation Delay Test Circuit



## 7 Detailed Description

### 7.1 Overview

The 'HC540 and CD74HCT540 are Inverting Octal Buffers and Line Drivers with Three-State Outputs and the capability to drive 15 LSTTL loads. The 'HC541 and 'HCT541 are Noninverting Octal Buffers and Line Drivers with Three-State Outputs that can drive 15 LSTTL loads. The Output Enables ( $\overline{OE1}$ ) and ( $\overline{OE2}$ ) control the Three-State Outputs. If either  $\overline{OE1}$  or  $\overline{OE2}$  is HIGH the outputs will be in the high impedance state. For data output  $\overline{OE1}$  and  $\overline{OE2}$  both must be LOW.

### 7.2 Functional Block Diagram

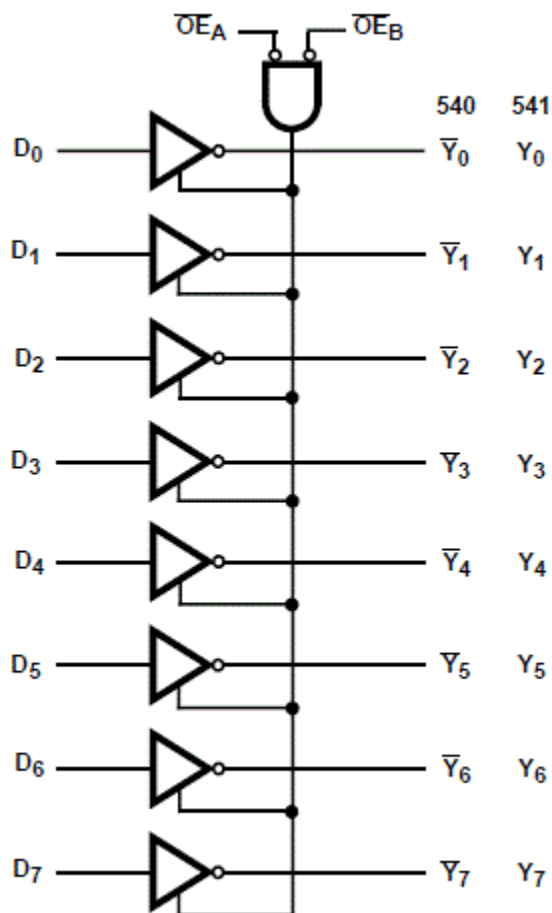

### 7.3 Device Functional Modes

表 7-1. Truth Table<sup>(1)</sup>

INPUTS			OUTPUTS	
OE1	OE2	An	540	541
L	L	H	L	H
H	X	X	Z	Z
X	H	X	Z	Z
L	L	L	H	L

(1) H = high voltage level, L = low voltage level, X = don't care, Z = high impedance

## 8 Power Supply Recommendations

The power supply can be any voltage between the minimum and maximum supply voltage rating located in the *Recommended Operating Conditions*. Each  $V_{CC}$  terminal should have a good bypass capacitor to prevent power disturbance. A 0.1- $\mu$ F capacitor is recommended for this device. It is acceptable to parallel multiple bypass capacitors to reject different frequencies of noise. The 0.1- $\mu$ F and 1- $\mu$ F capacitors are commonly used in parallel. The bypass capacitor should be installed as close to the power terminal as possible for best results.

## 9 Layout

### 9.1 Layout Guidelines

When using multiple-input and multiple-channel logic devices, inputs must not ever be left floating. In many cases, functions or parts of functions of digital logic devices are unused; for example, when only two inputs of a triple-input AND gate are used or only 3 of the 4 buffer gates are used. Such unused input pins must not be left unconnected because the undefined voltages at the outside connections result in undefined operational states. All unused inputs of digital logic devices must be connected to a logic high or logic low voltage, as defined by the input voltage specifications, to prevent them from floating. The logic level that must be applied to any particular unused input depends on the function of the device. Generally, the inputs are tied to GND or  $V_{CC}$ , whichever makes more sense for the logic function or is more convenient.



## 10 Device and Documentation Support

TI offers an extensive line of development tools. Tools and software to evaluate the performance of the device, generate code, and develop solutions are listed below.

### 10.1 Receiving Notification of Documentation Updates

To receive notification of documentation updates, navigate to the device product folder on [ti.com](http://ti.com). Click on *Subscribe to updates* to register and receive a weekly digest of any product information that has changed. For change details, review the revision history included in any revised document.

### 10.2 サポート・リソース

TI E2E™ サポート・フォーラムは、エンジニアが検証済みの回答と設計に関するヒントをエキスパートから迅速かつ直接得ることができる場所です。既存の回答を検索したり、独自の質問をしたりすることで、設計に必要な支援を迅速に得ることができます。

リンクされているコンテンツは、該当する貢献者により、現状のまま提供されるものです。これらは TI の仕様を構成するものではなく、必ずしも TI の見解を反映したものではありません。TI の [使用条件](#) を参照してください。

### 10.3 Trademarks

TI E2E™ is a trademark of Texas Instruments.

すべての商標は、それぞれの所有者に帰属します。

### 10.4 Electrostatic Discharge Caution



This integrated circuit can be damaged by ESD. Texas Instruments recommends that all integrated circuits be handled with appropriate precautions. Failure to observe proper handling and installation procedures can cause damage.

ESD damage can range from subtle performance degradation to complete device failure. Precision integrated circuits may be more susceptible to damage because very small parametric changes could cause the device not to meet its published specifications.

### 10.5 Glossary

[TI Glossary](#) This glossary lists and explains terms, acronyms, and definitions.

## 11 Mechanical, Packaging, and Orderable Information

The following pages include mechanical, packaging, and orderable information. This information is the most current data available for the designated devices. This data is subject to change without notice and revision of this document. For browser-based versions of this data sheet, refer to the left-hand navigation.

**PACKAGING INFORMATION**

Orderable Device	Status (1)	Package Type	Package Drawing	Pins	Package Qty	Eco Plan (2)	Lead finish/ Ball material (6)	MSL Peak Temp (3)	Op Temp (°C)	Device Marking (4/5)	Samples
CD54HC540F3A	ACTIVE	CDIP	J	20	20	Non-RoHS & Green	SNPB	N / A for Pkg Type	-55 to 125	CD54HC540F3A	<a href="#">Samples</a>
CD54HC541F	ACTIVE	CDIP	J	20	20	Non-RoHS & Green	SNPB	N / A for Pkg Type	-55 to 125	CD54HC541F	<a href="#">Samples</a>
CD54HC541F3A	ACTIVE	CDIP	J	20	20	Non-RoHS & Green	SNPB	N / A for Pkg Type	-55 to 125	CD54HC541F3A	<a href="#">Samples</a>
CD54HCT541F	ACTIVE	CDIP	J	20	20	Non-RoHS & Green	SNPB	N / A for Pkg Type	-55 to 125	CD54HCT541F	<a href="#">Samples</a>
CD54HCT541F3A	ACTIVE	CDIP	J	20	20	Non-RoHS & Green	SNPB	N / A for Pkg Type	-55 to 125	CD54HCT541F3A	<a href="#">Samples</a>
CD74HC540E	ACTIVE	PDIP	N	20	20	RoHS & Non-Green	NIPDAU	N / A for Pkg Type	-55 to 125	CD74HC540E	<a href="#">Samples</a>
CD74HC540M96	ACTIVE	SOIC	DW	20	2000	RoHS & Green	NIPDAU	Level-1-260C-UNLIM	-55 to 125	HC540M	<a href="#">Samples</a>
CD74HC541E	ACTIVE	PDIP	N	20	20	RoHS & Green	NIPDAU	N / A for Pkg Type	-55 to 125	CD74HC541E	<a href="#">Samples</a>
CD74HC541EE4	ACTIVE	PDIP	N	20	20	RoHS & Green	NIPDAU	N / A for Pkg Type	-55 to 125	CD74HC541E	<a href="#">Samples</a>
CD74HC541M96	ACTIVE	SOIC	DW	20	2000	RoHS & Green	NIPDAU	Level-1-260C-UNLIM	-55 to 125	HC541M	<a href="#">Samples</a>
CD74HC541M96G4	ACTIVE	SOIC	DW	20	2000	RoHS & Green	NIPDAU	Level-1-260C-UNLIM	-55 to 125	HC541M	<a href="#">Samples</a>
CD74HC541PWR	ACTIVE	TSSOP	PW	20	2000	RoHS & Green	NIPDAU	Level-1-260C-UNLIM	-55 to 125	HJ541	<a href="#">Samples</a>
CD74HCT540E	ACTIVE	PDIP	N	20	20	RoHS & Green	NIPDAU	N / A for Pkg Type	-55 to 125	CD74HCT540E	<a href="#">Samples</a>
CD74HCT540M96	ACTIVE	SOIC	DW	20	2000	RoHS & Green	NIPDAU	Level-1-260C-UNLIM	-55 to 125	HCT540M	<a href="#">Samples</a>
CD74HCT541E	ACTIVE	PDIP	N	20	20	RoHS & Green	NIPDAU	N / A for Pkg Type	-55 to 125	CD74HCT541E	<a href="#">Samples</a>
CD74HCT541M96	ACTIVE	SOIC	DW	20	2000	RoHS & Green	NIPDAU	Level-1-260C-UNLIM	-55 to 125	HCT541M	<a href="#">Samples</a>
CD74HCT541M96E4	ACTIVE	SOIC	DW	20	2000	RoHS & Green	NIPDAU	Level-1-260C-UNLIM	-55 to 125	HCT541M	<a href="#">Samples</a>
CD74HCT541M96G4	ACTIVE	SOIC	DW	20	2000	RoHS & Green	NIPDAU	Level-1-260C-UNLIM	-55 to 125	HCT541M	<a href="#">Samples</a>

(1) The marketing status values are defined as follows:

**ACTIVE:** Product device recommended for new designs.

**LIFEBUY:** TI has announced that the device will be discontinued, and a lifetime-buy period is in effect.

**NRND:** Not recommended for new designs. Device is in production to support existing customers, but TI does not recommend using this part in a new design.

**PREVIEW:** Device has been announced but is not in production. Samples may or may not be available.

**OBSOLETE:** TI has discontinued the production of the device.

<sup>(2)</sup> **RoHS:** TI defines "RoHS" to mean semiconductor products that are compliant with the current EU RoHS requirements for all 10 RoHS substances, including the requirement that RoHS substance do not exceed 0.1% by weight in homogeneous materials. Where designed to be soldered at high temperatures, "RoHS" products are suitable for use in specified lead-free processes. TI may reference these types of products as "Pb-Free".

**RoHS Exempt:** TI defines "RoHS Exempt" to mean products that contain lead but are compliant with EU RoHS pursuant to a specific EU RoHS exemption.

**Green:** TI defines "Green" to mean the content of Chlorine (Cl) and Bromine (Br) based flame retardants meet JS709B low halogen requirements of <=1000ppm threshold. Antimony trioxide based flame retardants must also meet the <=1000ppm threshold requirement.

<sup>(3)</sup> MSL, Peak Temp. - The Moisture Sensitivity Level rating according to the JEDEC industry standard classifications, and peak solder temperature.

<sup>(4)</sup> There may be additional marking, which relates to the logo, the lot trace code information, or the environmental category on the device.

<sup>(5)</sup> Multiple Device Markings will be inside parentheses. Only one Device Marking contained in parentheses and separated by a "~" will appear on a device. If a line is indented then it is a continuation of the previous line and the two combined represent the entire Device Marking for that device.

<sup>(6)</sup> Lead finish/Ball material - Orderable Devices may have multiple material finish options. Finish options are separated by a vertical ruled line. Lead finish/Ball material values may wrap to two lines if the finish value exceeds the maximum column width.

**Important Information and Disclaimer:**The information provided on this page represents TI's knowledge and belief as of the date that it is provided. TI bases its knowledge and belief on information provided by third parties, and makes no representation or warranty as to the accuracy of such information. Efforts are underway to better integrate information from third parties. TI has taken and continues to take reasonable steps to provide representative and accurate information but may not have conducted destructive testing or chemical analysis on incoming materials and chemicals. TI and TI suppliers consider certain information to be proprietary, and thus CAS numbers and other limited information may not be available for release.

In no event shall TI's liability arising out of such information exceed the total purchase price of the TI part(s) at issue in this document sold by TI to Customer on an annual basis.

**OTHER QUALIFIED VERSIONS OF CD54HC540, CD54HC541, CD54HCT541, CD74HC540, CD74HC541, CD74HCT541 :**

● Catalog : [CD74HC540](#), [CD74HC541](#), [CD74HCT541](#)

● Military : [CD54HC540](#), [CD54HC541](#), [CD54HCT541](#)

NOTE: Qualified Version Definitions:

● Catalog - TI's standard catalog product

---

- Military - QML certified for Military and Defense Applications

**TAPE AND REEL INFORMATION**

**QUADRANT ASSIGNMENTS FOR PIN 1 ORIENTATION IN TAPE**

\*All dimensions are nominal

Device	Package Type	Package Drawing	Pins	SPQ	Reel Diameter (mm)	Reel Width W1 (mm)	A0 (mm)	B0 (mm)	K0 (mm)	P1 (mm)	W (mm)	Pin1 Quadrant
CD74HC540M96	SOIC	DW	20	2000	330.0	24.4	10.8	13.3	2.7	12.0	24.0	Q1
CD74HC541M96	SOIC	DW	20	2000	330.0	24.4	10.9	13.3	2.7	12.0	24.0	Q1
CD74HC541M96	SOIC	DW	20	2000	330.0	24.4	10.8	13.3	2.7	12.0	24.0	Q1
CD74HC541PWR	TSSOP	PW	20	2000	330.0	16.4	6.95	7.0	1.4	8.0	16.0	Q1
CD74HC541PWR	TSSOP	PW	20	2000	330.0	16.4	6.95	7.1	1.6	8.0	16.0	Q1
CD74HCT540M96	SOIC	DW	20	2000	330.0	24.4	10.9	13.3	2.7	12.0	24.0	Q1
CD74HCT540M96	SOIC	DW	20	2000	330.0	24.4	10.8	13.3	2.7	12.0	24.0	Q1
CD74HCT541M96	SOIC	DW	20	2000	330.0	24.4	10.8	13.3	2.7	12.0	24.0	Q1
CD74HCT541M96	SOIC	DW	20	2000	330.0	24.4	10.9	13.3	2.7	12.0	24.0	Q1

## TAPE AND REEL BOX DIMENSIONS



\*All dimensions are nominal

Device	Package Type	Package Drawing	Pins	SPQ	Length (mm)	Width (mm)	Height (mm)
CD74HC540M96	SOIC	DW	20	2000	367.0	367.0	45.0
CD74HC541M96	SOIC	DW	20	2000	367.0	367.0	45.0
CD74HC541M96	SOIC	DW	20	2000	367.0	367.0	45.0
CD74HC541PWR	TSSOP	PW	20	2000	356.0	356.0	35.0
CD74HC541PWR	TSSOP	PW	20	2000	356.0	356.0	35.0
CD74HCT540M96	SOIC	DW	20	2000	356.0	356.0	41.0
CD74HCT540M96	SOIC	DW	20	2000	367.0	367.0	45.0
CD74HCT541M96	SOIC	DW	20	2000	367.0	367.0	45.0
CD74HCT541M96	SOIC	DW	20	2000	356.0	356.0	41.0



**TUBE**

\*All dimensions are nominal

Device	Package Name	Package Type	Pins	SPQ	L (mm)	W (mm)	T (μm)	B (mm)
CD74HC540E	N	PDIP	20	20	506	13.97	11230	4.32
CD74HC541E	N	PDIP	20	20	506	13.97	11230	4.32
CD74HC541EE4	N	PDIP	20	20	506	13.97	11230	4.32
CD74HCT540E	N	PDIP	20	20	506	13.97	11230	4.32
CD74HCT541E	N	PDIP	20	20	506	13.97	11230	4.32

J (R-GDIP-T\*\*)

14 LEADS SHOWN

CERAMIC DUAL IN-LINE PACKAGE



DIM \ PINS **	14	16	18	20
A	0.300 (7,62) BSC	0.300 (7,62) BSC	0.300 (7,62) BSC	0.300 (7,62) BSC
B MAX	0.785 (19,94)	.840 (21,34)	0.960 (24,38)	1.060 (26,92)
B MIN	—	—	—	—
C MAX	0.300 (7,62)	0.300 (7,62)	0.310 (7,87)	0.300 (7,62)
C MIN	0.245 (6,22)	0.245 (6,22)	0.220 (5,59)	0.245 (6,22)



4040083/F 03/03

- NOTES:
- A. All linear dimensions are in inches (millimeters).
  - B. This drawing is subject to change without notice.
  - C. This package is hermetically sealed with a ceramic lid using glass frit.
  - D. Index point is provided on cap for terminal identification only on press ceramic glass frit seal only.
  - E. Falls within MIL STD 1835 GDIP1-T14, GDIP1-T16, GDIP1-T18 and GDIP1-T20.

N (R-PDIP-T\*\*)

PLASTIC DUAL-IN-LINE PACKAGE

16 PINS SHOWN



4040049/E 12/2002

- NOTES:
- A. All linear dimensions are in inches (millimeters).
  - B. This drawing is subject to change without notice.
  - $\triangle C$  Falls within JEDEC MS-001, except 18 and 20 pin minimum body length (Dim A).
  - $\triangle D$  The 20 pin end lead shoulder width is a vendor option, either half or full width.

# DW0020A



# PACKAGE OUTLINE

## SOIC - 2.65 mm max height

SOIC



4220724/A 05/2016

**NOTES:**

1. All linear dimensions are in millimeters. Dimensions in parenthesis are for reference only. Dimensioning and tolerancing per ASME Y14.5M.
2. This drawing is subject to change without notice.
3. This dimension does not include mold flash, protrusions, or gate burrs. Mold flash, protrusions, or gate burrs shall not exceed 0.15 mm per side.
4. This dimension does not include interlead flash. Interlead flash shall not exceed 0.43 mm per side.
5. Reference JEDEC registration MS-013.

# EXAMPLE BOARD LAYOUT

DW0020A

SOIC - 2.65 mm max height

SOIC



LAND PATTERN EXAMPLE  
SCALE:6X



SOLDER MASK DETAILS

4220724/A 05/2016

NOTES: (continued)

- 6. Publication IPC-7351 may have alternate designs.
- 7. Solder mask tolerances between and around signal pads can vary based on board fabrication site.

# EXAMPLE STENCIL DESIGN

DW0020A

SOIC - 2.65 mm max height

SOIC



SOLDER PASTE EXAMPLE  
BASED ON 0.125 mm THICK STENCIL  
SCALE:6X

4220724/A 05/2016

NOTES: (continued)

8. Laser cutting apertures with trapezoidal walls and rounded corners may offer better paste release. IPC-7525 may have alternate design recommendations.
9. Board assembly site may have different recommendations for stencil design.

PW0020A



# PACKAGE OUTLINE

## TSSOP - 1.2 mm max height

SMALL OUTLINE PACKAGE



4220206/A 02/2017

NOTES:

- All linear dimensions are in millimeters. Any dimensions in parenthesis are for reference only. Dimensioning and tolerancing per ASME Y14.5M.
- This drawing is subject to change without notice.
- This dimension does not include mold flash, protrusions, or gate burrs. Mold flash, protrusions, or gate burrs shall not exceed 0.15 mm per side.
- This dimension does not include interlead flash. Interlead flash shall not exceed 0.25 mm per side.
- Reference JEDEC registration MO-153.

# EXAMPLE BOARD LAYOUT

PW0020A

TSSOP - 1.2 mm max height

SMALL OUTLINE PACKAGE



LAND PATTERN EXAMPLE  
EXPOSED METAL SHOWN  
SCALE: 10X



SOLDER MASK DETAILS

4220206/A 02/2017

NOTES: (continued)

- 6. Publication IPC-7351 may have alternate designs.
- 7. Solder mask tolerances between and around signal pads can vary based on board fabrication site.



# EXAMPLE STENCIL DESIGN

PW0020A

TSSOP - 1.2 mm max height

SMALL OUTLINE PACKAGE



SOLDER PASTE EXAMPLE  
BASED ON 0.125 mm THICK STENCIL  
SCALE: 10X

4220206/A 02/2017

NOTES: (continued)

8. Laser cutting apertures with trapezoidal walls and rounded corners may offer better paste release. IPC-7525 may have alternate design recommendations.
9. Board assembly site may have different recommendations for stencil design.

PW (R-PDSO-G20)

PLASTIC SMALL OUTLINE



- NOTES:
- A. All linear dimensions are in millimeters.
  - B. This drawing is subject to change without notice.
  - C. Publication IPC-7351 is recommended for alternate design.
  - D. Laser cutting apertures with trapezoidal walls and also rounding corners will offer better paste release. Customers should contact their board assembly site for stencil design recommendations. Refer to IPC-7525 for other stencil recommendations.
  - E. Customers should contact their board fabrication site for solder mask tolerances between and around signal pads.

## 重要なお知らせと免責事項

TI は、技術データと信頼性データ (データシートを含みます)、設計リソース (リファレンス・デザインを含みます)、アプリケーションや設計に関する各種アドバイス、Web ツール、安全性情報、その他のリソースを、欠陥が存在する可能性のある「現状のまま」提供しており、商品性および特定目的に対する適合性の黙示保証、第三者の知的財産権の非侵害保証を含むいかなる保証も、明示的または黙示的にかかわらず拒否します。

これらのリソースは、TI 製品を使用する設計の経験を積んだ開発者への提供を意図したものです。(1) お客様のアプリケーションに適した TI 製品の選定、(2) お客様のアプリケーションの設計、検証、試験、(3) お客様のアプリケーションに該当する各種規格や、その他のあらゆる安全性、セキュリティ、規制、または他の要件への確実な適合に関する責任を、お客様のみが単独で負うものとし、

上記の各種リソースは、予告なく変更される可能性があります。これらのリソースは、リソースで説明されている TI 製品を使用するアプリケーションの開発の目的でのみ、TI はその使用をお客様に許諾します。これらのリソースに関して、他の目的で複製することや掲載することは禁止されています。TI や第三者の知的財産権のライセンスが付与されている訳ではありません。お客様は、これらのリソースを自身で使用した結果発生するあらゆる申し立て、損害、費用、損失、責任について、TI およびその代理人を完全に補償するものとし、TI は一切の責任を拒否します。

TI の製品は、[TI の販売条件](#)、または [ti.com](#) やかかる TI 製品の関連資料などのいずれかを通じて提供する適用可能な条項の下で提供されています。TI がこれらのリソースを提供することは、適用される TI の保証または他の保証の放棄の拡大や変更を意味するものではありません。

お客様がいかなる追加条項または代替条項を提案した場合でも、TI はそれらに異議を唱え、拒否します。

郵送先住所 : Texas Instruments, Post Office Box 655303, Dallas, Texas 75265  
Copyright © 2024, Texas Instruments Incorporated