

# ISO6740/ISO6740-Q1 Functional Safety FIT Rate, FMD and Pin FMA



## Table of Contents

|  |   |
|--|---|
| <b>1 Overview</b> .....                                      | 2 |
| <b>2 Functional Safety Failure In Time (FIT) Rates</b> ..... | 3 |
| 2.1 16-SOIC (wide-body SOIC) Package.....                    | 3 |
| <b>3 Failure Mode Distribution (FMD)</b> .....               | 4 |
| <b>4 Pin Failure Mode Analysis (Pin FMA)</b> .....           | 5 |
| 4.1 16-DW (wide-body SOIC) Package.....                      | 5 |

## Trademarks

All trademarks are the property of their respective owners.

## 1 Overview

This document contains information for ISO6740/ISO6740-Q1 and ISO6740F/ISO6740F-Q1 (16-DW package) to aid in a functional safety system design. Information provided are:

- Functional Safety Failure In Time (FIT) rates of the semiconductor component estimated by the application of industry reliability standards
- Component failure modes and their distribution (FMD) based on the primary function of the device
- Pin failure mode analysis (Pin FMA)

Figure 1-1 shows the device functional block diagram for reference.

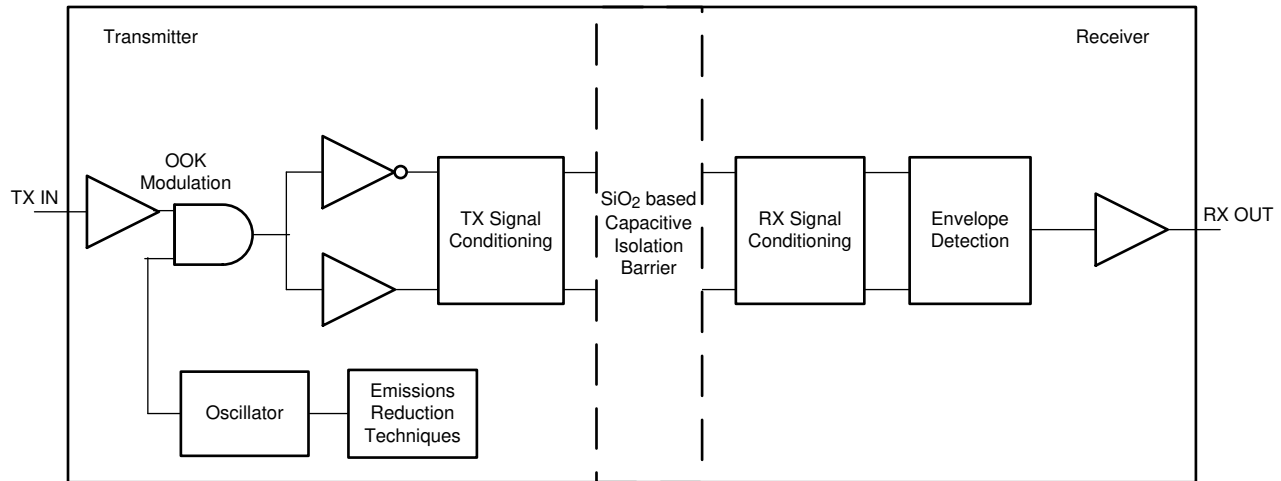

**Figure 1-1. Functional Block Diagram**

ISO6740/ISO6740-Q1 and ISO6740F/ISO6740F-Q1 were developed using a quality-managed development process, but was not developed in accordance with the IEC 61508 or ISO 26262 standards.

## 2 Functional Safety Failure In Time (FIT) Rates

### 2.1 16-SOIC (wide-body SOIC) Package

This section provides Functional Safety Failure In Time (FIT) rates for the 16-SOIC package of ISO6740/ISO6740-Q1 and ISO6740F/ISO6740F-Q1 based on two different industry-wide used reliability standards:

- [Table 2-1](#) provides FIT rates based on IEC TR 62380 / ISO 26262 part 11
- [Table 2-2](#) provides FIT rates based on the Siemens Norm SN 29500-2

**Table 2-1. Component Failure Rates per IEC TR 62380 / ISO 26262 Part 11**

| FIT IEC TR 62380 / ISO 26262 | FIT (Failures Per 10 <sup>9</sup> Hours) |
|------------------------------|--|
| Total Component FIT Rate     | 28                                       |
| Die FIT Rate                 | 3  |
| Package FIT Rate             | 25                                       |

The failure rate and mission profile information in [Table 2-1](#) comes from the Reliability data handbook IEC TR 62380 / ISO 26262 part 11:

- Mission Profile: Motor Control from Table 11
- Power dissipation: 200 mW
- Climate type: World-wide Table 8
- Package factor ( $\lambda_3$ ): Table 17b
- Substrate Material: FR4
- EOS FIT rate assumed: 0 FIT

**Table 2-2. Component Failure Rates per Siemens Norm SN 29500-2**

| Table | Category                                | Reference FIT Rate | Reference Virtual T <sub>J</sub> |
|-------|---|--------------------|----------------------------------|
| 5     | CMOS, BICMOS<br>Digital, analog / mixed | 25 FIT             | 55 °C                            |

The Reference FIT Rate and Reference Virtual T<sub>J</sub> (junction temperature) in [Table 2-2](#) come from the Siemens Norm SN 29500-2 tables 1 through 5. Failure rates under operating conditions are calculated from the reference failure rate and virtual junction temperature using conversion information in SN 29500-2 section 4.

### 3 Failure Mode Distribution (FMD)

The failure mode distribution estimation for ISO6740/ISO6740-Q1 and ISO6740F/ISO6740F-Q1 in [Table 3-1](#) comes from the combination of common failure modes listed in standards such as IEC 61508 and ISO 26262, the ratio of sub-circuit function size and complexity and from best engineering judgment.

The failure modes listed in this section reflect random failure events and do not include failures due to misuse or overstress.

**Table 3-1. Die Failure Modes and Distribution**

| Die Failure Modes                          | Failure Mode Distribution (%) |
|--|-------------------------------|
| OUT state undetermined                     | 35%                           |
| OUT not in timing or voltage specification | 30%                           |
| OUT stuck to default state                 | 25%                           |
| OUT stuck high                             | 5%                            |
| OUT stuck low                              | 5%                            |

The FMD in [Table 3-1](#) excludes short circuit faults across the isolation barrier. Faults for short circuit across the isolation barrier can be excluded according to ISO 61800-5-2:2016 if the following requirements are fulfilled:

1. The signal isolation component is OVC III according to IEC 61800-5-1. If a SELV/PELV power supply is used, pollution degree 2/OVC II applies. All requirements of IEC 61800-5-1:2007, 4.3.6 apply.
2. Measures are taken to ensure that an internal failure of the signal isolation component cannot result in excessive temperature of its insulating material.

Creepage and clearance requirements should be applied according to the specific equipment isolation standards of an application. Care should be taken to maintain the creepage and clearance distance of a board design to ensure that the mounting pads of the isolator on the printed-circuit board do not reduce this distance.

## 4 Pin Failure Mode Analysis (Pin FMA)

This section provides a Failure Mode Analysis (FMA) for the pins of the ISO6740/ISO6740-Q1 and ISO6740F/ISO6740F-Q1 (16-DW package). The failure modes covered in this document include the typical pin-by-pin failure scenarios:

- Pin short-circuited to Ground (see [Table 4-2](#))
- Pin open-circuited (see [Table 4-3](#))
- Pin short-circuited to an adjacent pin (see [Table 4-4](#))
- Pin short-circuited to supply (see [Table 4-5](#))

[Table 4-2](#) through [Table 4-5](#) also indicate how these pin conditions can affect the device as per the failure effects classification in [Table 4-1](#). Note that when pin short to ground case is discussed, only same side ground shorts are considered.

**Table 4-1. TI Classification of Failure Effects**

| Class | Failure Effects   |
|-------|---|
| A     | Potential device damage that affects functionality          |
| B     | No device damage, but loss of functionality                 |
| C     | No device damage, but performance degradation               |
| D     | No device damage, no impact to functionality or performance |

### 4.1 16-DW (wide-body SOIC) Package

[Figure 4-1](#) shows the ISO6740/ISO6740-Q1 and ISO6740F/ISO6740F-Q1 pin diagram for the 16-DW package. For a detailed description of the device pins please refer to the *Pin Configuration and Functions* section in the ISO6740/ISO6740-Q1 data sheet.

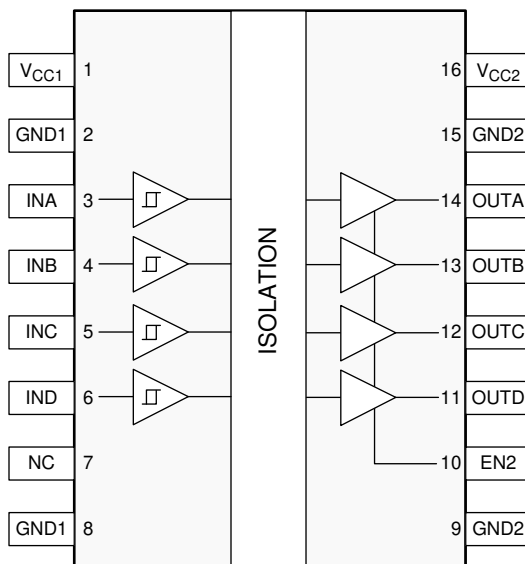

**Figure 4-1. Pin Diagram (16-DW) Package**

**Table 4-2. Pin FMA for Device Pins Short-Circuited to Ground**

| Pin Name         | Pin No. | Description of Potential Failure Effect(s)  | Failure Effect Class |
|------------------|---------|---|----------------------|
| V <sub>CC1</sub> | 1       | No power to the device on side-1. Observe that the absolute maximum ratings for all pins of the device are met; otherwise device damage may be plausible. | A                    |
| GND1             | 2       | Device continues to function as expected. Normal operation.   | D                    |
| INA              | 3       | Input signal shorted to ground, so output (OUTA) stuck to low. Communication from INA to OUTA corrupted.  | B                    |
| INB              | 4       | Input signal shorted to ground, so output (OUTB) stuck to low. Communication from INB to OUTB corrupted.  | B                    |
| INC              | 5       | Input signal shorted to ground, so output (OUTC) stuck to low. Communication from INC to OUTC corrupted.  | B                    |
| IND              | 6       | Input signal shorted to ground, so output (OUTD) stuck to low. Communication from IND to OUTD corrupted.  | B                    |
| NC               | 7       | Device continues to function as expected. Normal operation.   | D                    |
| GND1             | 8       | Device continues to function as expected. Normal operation.   | D                    |
| GND2             | 9       | Device continues to function as expected. Normal operation.   | D                    |
| EN2              | 10      | Disables the output buffer for all 4 Output channels. Communication corrupted.  | B                    |
| OUTD             | 11      | OUTD stuck low. Data communication from IND to OUTD lost. Device damage possible if IND is driven high for extended period of time.                       | A                    |
| OUTC             | 12      | OUTC stuck low. Data communication from INC to OUTC lost. Device damage possible if INC is driven high for extended period of time.                       | A                    |
| OUTB             | 13      | OUTB stuck low. Data communication from INB to OUTB lost. Device damage possible if INB is driven high for extended period of time.                       | A                    |
| OUTA             | 14      | OUTA stuck low. Data communication from INA to OUTA lost. Device damage possible if INA is driven high for extended period of time.                       | A                    |
| GND2             | 15      | Device continues to function as expected. Normal operation.   | D                    |
| V <sub>CC2</sub> | 16      | No power to the device on side-2. OUTA/OUTB/OUTC/OUTD pins state undetermined.  | B                    |

**Table 4-3. Pin FMA for Device Pins Open-Circuited**

| Pin Name         | Pin No. | Description of Potential Failure Effect(s)  | Failure Effect Class |
|------------------|---------|---|----------------------|
| V <sub>CC1</sub> | 1       | Operation undetermined. Either device is unpowered and OUTA/OUTB/OUTC/OUTD=default logic state or through internal ESD diode on any IN pin, device can power up if any IN is driven to logic high. If IN has current sourcing capability to provide regular operating current of device, ESD diode conducts that current and device damage plausible. | A                    |
| GND1             | 2       | Device gets return ground through pin8. Normal operation.   | D                    |
| INA              | 3       | No communication to INA channel possible. OUTA stuck to default state (High for ISO6740/ISO6740-Q1 and Low for ISO6740F/ISO6740F-Q1).   | B                    |
| INB              | 4       | No communication to INB channel possible. OUTB stuck to default state (High for ISO6740/ISO6740-Q1 and Low for ISO6740F/ISO6740F-Q1).   | B                    |
| INC              | 5       | No communication to INC channel possible. OUTC stuck to default state (High for ISO6740/ISO6740-Q1 and Low for ISO6740F/ISO6740F-Q1).   | B                    |
| IND              | 6       | No communication to IND channel possible. OUTD stuck to default state (High for ISO6740/ISO6740-Q1 and Low for ISO6740F/ISO6740F-Q1).   | B                    |
| NC               | 7       | Device continues to function as expected. Normal operation.   | D                    |
| GND1             | 8       | Device gets return ground through pin2. Normal operation.   | D                    |
| GND2             | 9       | Device gets return ground through pin15. Normal operation.  | D                    |
| EN2              | 10      | Control on output buffer lost, but communication from IN to OUT channels continues normally.  | B                    |
| OUTD             | 11      | State of OUTD undetermined. Data communication from IND to OUTD lost.   | B                    |
| OUTC             | 12      | State of OUTC undetermined. Data communication from INC to OUTC lost.   | B                    |
| OUTB             | 13      | State of OUTB undetermined. Data communication from INB to OUTB lost.   | B                    |
| OUTA             | 14      | State of OUTA undetermined. Data communication from INA to OUTA lost.   | B                    |

**Table 4-3. Pin FMA for Device Pins Open-Circuited (continued)**

| Pin Name         | Pin No. | Description of Potential Failure Effect(s)                                | Failure Effect Class |
|------------------|---------|---|----------------------|
| GND2             | 15      | Device gets return ground through pin9. Normal operation.                 | D                    |
| V <sub>CC2</sub> | 16      | Device unpowered on side-2 and state of OUTA/OUTB/OUTC/OUTD undetermined. | B                    |

**Table 4-4. Pin FMA for Device Pins Short-Circuited to Adjacent Pin**

| Pin Name         | Pin No. | Shorted to       | Description of Potential Failure Effect(s)   | Failure Effect Class |
|------------------|---------|------------------|--|----------------------|
| V <sub>CC1</sub> | 1       | GND1             | No power to the device on side-1. Observe that the absolute maximum ratings for all pins of the device are met; otherwise device damage may be plausible.  | A                    |
| GND1             | 2       | INA              | Input signal shorted to ground, so output (OUTA) stuck to low. Communication from INA to OUTA corrupted.   | B                    |
| INA              | 3       | INB              | Communication corrupted for either INA or INB channel.   | B                    |
| INB              | 4       | INC              | Communication corrupted for either INC or INB channel.   | B                    |
| INC              | 5       | IND              | Communication corrupted for either INC or IND channel.   | B                    |
| IND              | 6       | NC               | Device continues to function as expected. Normal operation.  | D                    |
| NC               | 7       | GND1             | Device continues to function as expected. Normal operation.  | D                    |
| GND1             | 8       | NC               | Already considered in above row.   | D                    |
| GND2             | 9       | EN2              | Disables the output buffer for all 4 Output channels. Communication corrupted.   | B                    |
| EN2              | 10      | OUTD             | Communication corrupted on Channel D and on other channels as well when OUTD drives low.   | B                    |
| OUTD             | 11      | OUTC             | Communication corrupted for either OUTC or OUTD channel. Device damage possible if INC and IND try to drive opposite logic state for extended duration creating a short between supply and ground on side-2. | A                    |
| OUTC             | 12      | OUTB             | Communication corrupted for either OUTC or OUTB channel. Device damage possible if INC and INB try to drive opposite logic state for extended duration creating a short between supply and ground on side-2. | A                    |
| OUTB             | 13      | OUTA             | Communication corrupted for either OUTA or OUTB channel. Device damage possible if INA and INB try to drive opposite logic state for extended duration creating a short between supply and ground on side-2. | A                    |
| OUTA             | 14      | GND2             | OUTA stuck low. Data communication from INA to OUTA lost. Device damage possible if INA is driven high for extended period of time.  | A                    |
| GND2             | 15      | V <sub>CC2</sub> | No power to the device on side-2. OUTA/OUTB/OUTC/OUTD pins state undetermined.   | B                    |
| V <sub>CC2</sub> | 16      | GND2             | Already considered in above row.   | B                    |

**Table 4-5. Pin FMA for Device Pins Short-Circuited to supply**

| Pin Name         | Pin No. | Description of Potential Failure Effect(s)   | Failure Effect Class |
|------------------|---------|--|----------------------|
| V <sub>CC1</sub> | 1       | No effect. Normal operation.   | D                    |
| GND1             | 2       | This can create potential difference between pin2 and pin8, causing high current to flow in device and potential device damage.  | A                    |
| INA              | 3       | INA pin stuck high. Communication corrupted. OUTA state high.  | B                    |
| INB              | 4       | INB pin stuck high. Communication corrupted. OUTB state high.  | B                    |
| INC              | 5       | INC pin stuck high. Communication corrupted. OUTC state high.  | B                    |
| IND              | 6       | IND pin stuck high. Communication corrupted. OUTD state high.  | B                    |
| NC               | 7       | Device continues to function as expected. Normal operation.  | D                    |
| GND1             | 8       | This can create potential difference between pin2 and pin8, causing high current to flow in device and potential device damage.  | A                    |
| GND2             | 9       | This can create potential difference between pin9 and pin15, causing high current to flow in device and potential device damage. | A                    |
| EN2              | 10      | Functionality to disable output buffer lost. Communication for all channels normal.  | B                    |

**Table 4-5. Pin FMA for Device Pins Short-Circuited to supply (continued)**

| Pin Name         | Pin No. | Description of Potential Failure Effect(s)  | Failure Effect Class |
|------------------|---------|---|----------------------|
| OUTD             | 11      | OUTD stuck high. Communication disrupted. If IND is low for extended duration, OUTD being stuck high creates a short and can damage the device. | A                    |
| OUTC             | 12      | OUTC stuck high. Communication disrupted. If INC is low for extended duration, OUTC being stuck high creates a short and can damage the device. | A                    |
| OUTB             | 13      | OUTB stuck high. Communication disrupted. If INB is low for extended duration, OUTB being stuck high creates a short and can damage the device. | A                    |
| OUTA             | 14      | OUTA stuck high. Communication disrupted. If INA is low for extended duration, OUTA being stuck high creates a short and can damage the device. | A                    |
| GND2             | 15      | This can create potential difference between pin9 and pin15, causing high current to flow in device and potential device damage.                | A                    |
| V <sub>CC2</sub> | 16      | Device continues to function as expected. Normal operation.   | D                    |



## IMPORTANT NOTICE AND DISCLAIMER

TI PROVIDES TECHNICAL AND RELIABILITY DATA (INCLUDING DATASHEETS), DESIGN RESOURCES (INCLUDING REFERENCE DESIGNS), APPLICATION OR OTHER DESIGN ADVICE, WEB TOOLS, SAFETY INFORMATION, AND OTHER RESOURCES "AS IS" AND WITH ALL FAULTS, AND DISCLAIMS ALL WARRANTIES, EXPRESS AND IMPLIED, INCLUDING WITHOUT LIMITATION ANY IMPLIED WARRANTIES OF MERCHANTABILITY, FITNESS FOR A PARTICULAR PURPOSE OR NON-INFRINGEMENT OF THIRD PARTY INTELLECTUAL PROPERTY RIGHTS.

These resources are intended for skilled developers designing with TI products. You are solely responsible for (1) selecting the appropriate TI products for your application, (2) designing, validating and testing your application, and (3) ensuring your application meets applicable standards, and any other safety, security, or other requirements. These resources are subject to change without notice. TI grants you permission to use these resources only for development of an application that uses the TI products described in the resource. Other reproduction and display of these resources is prohibited. No license is granted to any other TI intellectual property right or to any third party intellectual property right. TI disclaims responsibility for, and you will fully indemnify TI and its representatives against, any claims, damages, costs, losses, and liabilities arising out of your use of these resources.

TI's products are provided subject to TI's Terms of Sale (<https://www.ti.com/legal/termsofsale.html>) or other applicable terms available either on [ti.com](https://www.ti.com) or provided in conjunction with such TI products. TI's provision of these resources does not expand or otherwise alter TI's applicable warranties or warranty disclaimers for TI products.

Mailing Address: Texas Instruments, Post Office Box 655303, Dallas, Texas 75265  
Copyright © 2021, Texas Instruments Incorporated