

# DRV5015 低電圧、高感度のデジタル・ラッチ・ホール・エフェクト・センサ

## 1 特長

- デジタル・ラッチ・ホール効果センサ
- 高精度の磁気感度
  - DRV5015A1:  $\pm 0.7\text{mT}$  (標準値)
  - DRV5015A2:  $\pm 1.8\text{mT}$  (標準値)
  - DRV5015A3:  $\pm 1.8\text{mT}$  (反転、標準値)
- ヒステリシス内蔵
- 高速な 30kHz センシング帯域幅
- 2.5V~5.5V の  $V_{CC}$  範囲で動作
- 20mA の電流を出力可能なオープン・ドレイン出力
- 動作温度範囲:  $-40^{\circ}\text{C} \sim +125^{\circ}\text{C}$

## 2 アプリケーション

- ブラシレスDCモータ・センサ
- インクリメンタル・ロータリー・エンコーダ
  - ブラシ付き DC モータ・フィードバック
  - モータ速度 (タコメータ)
  - 機械的移動
  - 流量測定
  - ヒューマン・インターフェイスのノブ
  - 車輪の速度
- 電動アシスト自転車

### 代表的な回路図

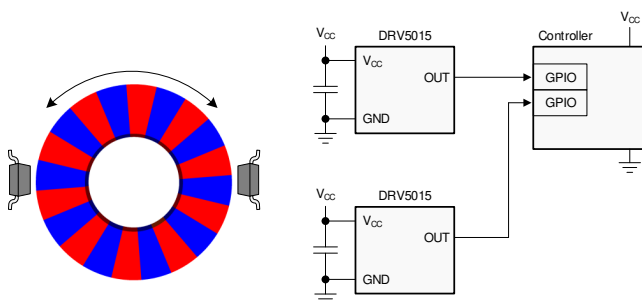

## 3 概要

DRV5015は低電圧のデジタル・ラッチ・ホール・エフェクト・センサで、高速および高温のモータ・アプリケーション用に設計されています。このデバイスは2.5V~5.5Vの電源で動作し、磁束密度を検出して、事前定義された磁気スレッシュホールドに基づいてデジタルで出力します。

出力をトグルするにはN極とS極の切り替えが必要で、内蔵のヒステリシスにより堅牢なスイッチングが行われます。

### 製品情報<sup>(1)</sup>

型番	パッケージ	本体サイズ(公称)
DRV5015	SOT-23 (3)	2.92mmx1.30mm

(1) 利用可能なすべてのパッケージについては、このデータシートの末尾にあるパッケージ・オプションについての付録を参照してください。

### 磁気応答

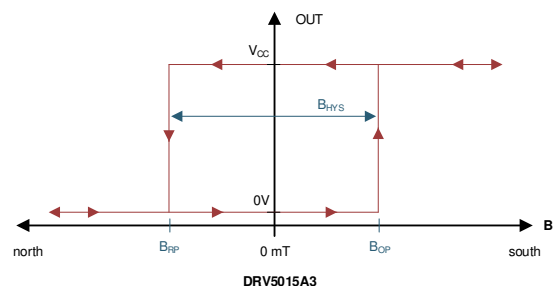
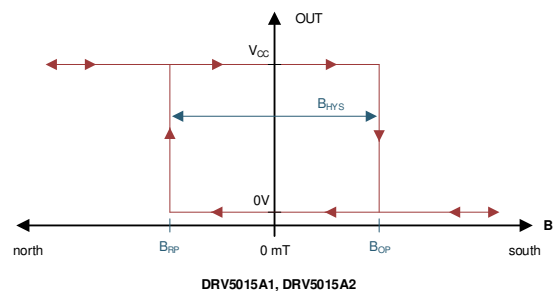

## 目次

1	特長	1	8.4	Device Functional Modes	13
2	アプリケーション	1	<b>9</b>	<b>Application and Implementation</b>	<b>14</b>
3	概要	1	9.1	Application Information	14
4	改訂履歴	2	9.2	Typical Applications	14
5	概要(続き)	3	9.3	What to Do and What Not to Do	17
<b>6</b>	<b>Pin Configuration and Functions</b>	<b>4</b>	<b>10</b>	<b>Power Supply Recommendations</b>	<b>18</b>
<b>7</b>	<b>Specifications</b>	<b>4</b>	<b>11</b>	<b>Layout</b>	<b>18</b>
7.1	Absolute Maximum Ratings	4	11.1	Layout Guidelines	18
7.2	ESD Ratings	4	11.2	Layout Example	18
7.3	Recommended Operating Conditions	5	<b>12</b>	<b>デバイスおよびドキュメントのサポート</b>	<b>19</b>
7.4	Thermal Information	5	12.1	ドキュメントのサポート	19
7.5	Electrical Characteristics	5	12.2	ドキュメントの更新通知を受け取る方法	19
7.6	Magnetic Characteristics	5	12.3	コミュニティ・リソース	19
7.7	Typical Characteristics	6	12.4	商標	19
<b>8</b>	<b>Detailed Description</b>	<b>8</b>	12.5	静電気放電に関する注意事項	19
8.1	Overview	8	12.6	Glossary	19
8.2	Functional Block Diagram	8	<b>13</b>	<b>メカニカル、パッケージ、および注文情報</b>	<b>19</b>
8.3	Feature Description	8			

## 4 改訂履歴

2018年6月発行のものから更新

Page

- Changed output voltage max value from  $V_{CC} + 0.3\text{ V}$  to  $6.0\text{ V}$  in the *Absolute Maximum Ratings* table ..... 4

## 5 概要（続き）

このデバイスは2つの磁気スレッシュホールド・オプションおよび1つの反転出力オプションで供給されます。磁気感度が高いため、低コストの磁石を選択し、コンポーネントを柔軟に配置できます。

このデバイスは、 $-40^{\circ}\text{C}$ ～ $+125^{\circ}\text{C}$ の広い周囲温度範囲で一貫した動作を行います。

## 6 Pin Configuration and Functions

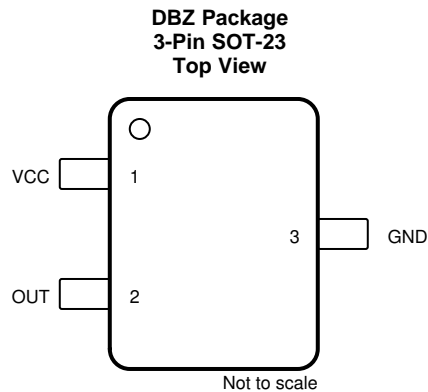

### Pin Functions

PIN		TYPE	DESCRIPTION
NAME	NO.		
GND	3	Ground	Ground reference.
OUT	2	Output	Open-drain output.
VCC	1	Power supply	2.5-V to 5.5-V power supply. Connect a ceramic capacitor with a value of at least 0.01 $\mu$ F between VCC and ground.

## 7 Specifications

### 7.1 Absolute Maximum Ratings

over operating free-air temperature range (unless otherwise noted)<sup>(1)</sup>

		MIN	MAX	UNIT
$V_{CC}$	Power supply voltage	-0.3	6.0	V
$V_{OUT}$	Output voltage	-0.3	6.0	V
$I_{OUT}$	Output current		30	mA
$B_{MAX}$	Magnetic flux density		Unlimited	T
$T_J$	Operating junction temperature	-40	150	°C
$T_{stg}$	Storage temperature	-65	150	°C

- (1) Stresses beyond those listed under Absolute Maximum Ratings may cause permanent damage to the device. These are stress ratings only, which do not imply functional operation of the device at these or any other conditions beyond those indicated under Recommended Operating Conditions. Exposure to absolute-maximum-rated conditions for extended periods may affect device reliability.

### 7.2 ESD Ratings

over operating free-air temperature range (unless otherwise noted)

			VALUE	UNIT
$V_{(ESD)}$	Electrostatic discharge	Human body model (HBM), per ANSI/ESDA/JEDEC JS-001 <sup>(1)</sup>	$\pm 5000$	V
		Charged device model (CDM), per JEDEC specification JESD22-C101 <sup>(2)</sup>	$\pm 1500$	V

(1) JEDEC document JEP155 states that 500-V HBM allows safe manufacturing with a standard ESD control process

(2) JEDEC document JEP157 states that 250-V CDM allows safe manufacturing with a standard ESD control process.

### 7.3 Recommended Operating Conditions

over operating free-air temperature range (unless otherwise noted)

		MIN	MAX	UNIT
V <sub>CC</sub>	Power supply voltage	2.5	5.5	V
V <sub>OUT</sub>	Output pin voltage	0	5.5	V
I <sub>OUT</sub>	Output sinking current	0	20	mA
T <sub>A</sub>	Operating ambient temperature	–40	125	°C

### 7.4 Thermal Information

THERMAL METRIC <sup>(1)</sup>		DRV5015		UNIT
		SOT-23 (DBZ)		
		3 PINS		
R <sub>θJA</sub>	Junction-to-ambient thermal resistance	356		°C/W
R <sub>θJC(top)</sub>	Junction-to-case (top) thermal resistance	128		°C/W
R <sub>θJB</sub>	Junction-to-board thermal resistance	94		°C/W
Y <sub>JT</sub>	Junction-to-top characterization parameter	11.4		°C/W
Y <sub>JB</sub>	Junction-to-board characterization parameter	92		°C/W

(1) For information about traditional and new thermal metrics, see the [Semiconductor and IC Package Thermal Metrics application report](#).

### 7.5 Electrical Characteristics

at V<sub>CC</sub> = 2.5 V to 5.5 V, over operating free-air temperature range (unless otherwise noted)

PARAMETER		TEST CONDITION	MIN	TYP	MAX	UNIT
I <sub>CC</sub>	Operating supply current			2.3	2.8	mA
t <sub>ON</sub>	Power-on time			40	70	μs
t <sub>d</sub>	Propagation delay time <sup>(1)</sup>	B = B <sub>RP</sub> – 10 mT to B <sub>OP</sub> + 10 mT in 1 μs		13	25	μs
I <sub>OZ</sub>	High-impedance output leakage current	5.5 V applied to OUT, while OUT is high-impedance			100	nA
V <sub>OL</sub>	Low-level output voltage	I <sub>OUT</sub> = 20 mA		0.15	0.4	V

(1) See the [Propagation Delay](#) section for more information.

### 7.6 Magnetic Characteristics

at V<sub>CC</sub> = 2.5 V to 5.5 V, over operating free-air temperature range (unless otherwise noted)

PARAMETER		TEST CONDITION	MIN	TYP	MAX	UNIT
<b>DRV5015A1, DRV5015A2, DRV5015A3</b>						
f <sub>BW</sub>	Sensing bandwidth		20	30		kHz
<b>DRV5015A1</b>						
B <sub>OP</sub>	Magnetic threshold operate point		–0.2	0.7	2.0	mT
B <sub>RP</sub>	Magnetic threshold release point		–2.0	–0.7	0.2	mT
B <sub>HYS</sub>	Magnetic hysteresis:  B <sub>OP</sub> – B <sub>RP</sub>		0.35	1.4		mT
<b>DRV5015A2/DRV5015A3</b>						
B <sub>OP</sub>	Magnetic threshold operate point		0.5	1.8	3.7	mT
B <sub>RP</sub>	Magnetic threshold release point		–3.7	–1.8	–0.5	mT
B <sub>HYS</sub>	Magnetic hysteresis:  B <sub>OP</sub> – B <sub>RP</sub>		2.3	3.6		mT

## 7.7 Typical Characteristics

at  $T_A = 25^\circ\text{C}$  typical (unless otherwise noted)

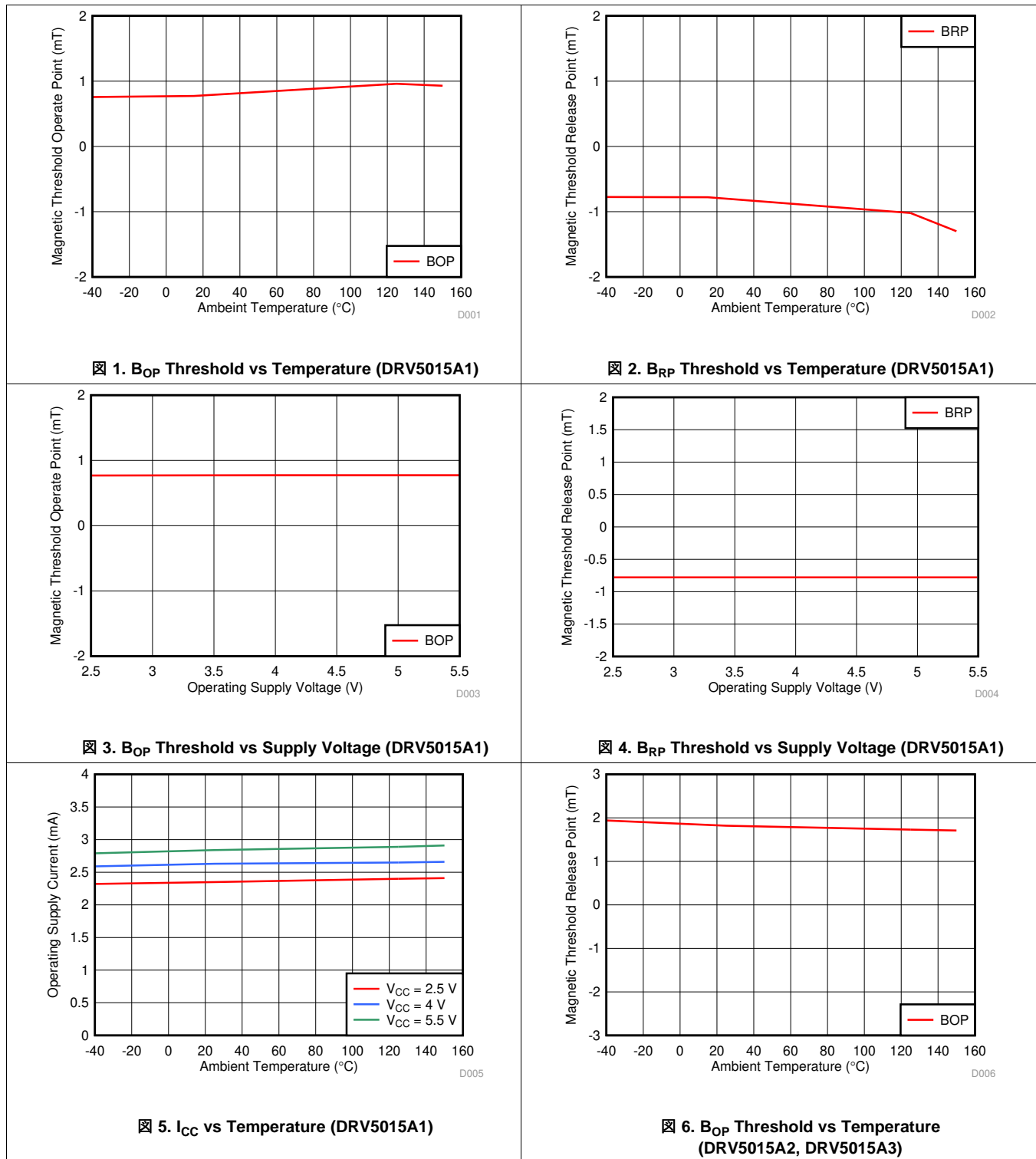

Typical Characteristics (continued)

at  $T_A = 25^\circ\text{C}$  typical (unless otherwise noted)



图 7.  $B_{RP}$  Threshold vs Temperature (DRV5015A2, DRV5015A3)



图 8.  $B_{OP}$  Threshold vs Supply Voltage (DRV5015A2, DRV5015A3)

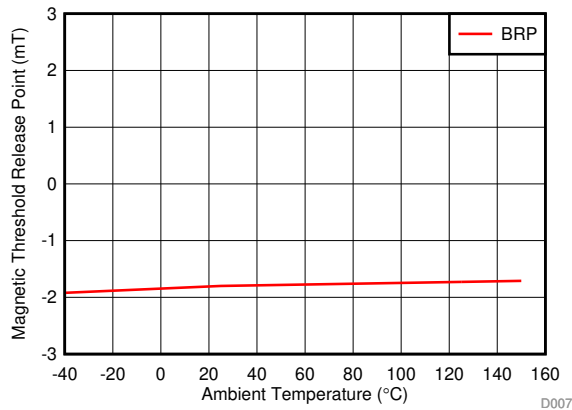

图 9.  $B_{RP}$  Threshold vs Supply Voltage (DRV5015A2, DRV5015A3)

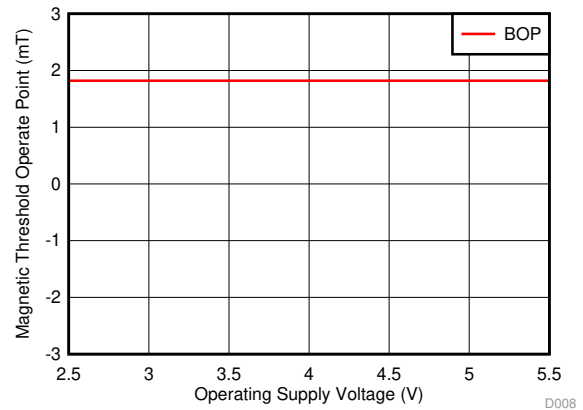

图 10.  $I_{CC}$  vs Temperature (DRV5015A2, DRV5015A3)

## 8 Detailed Description

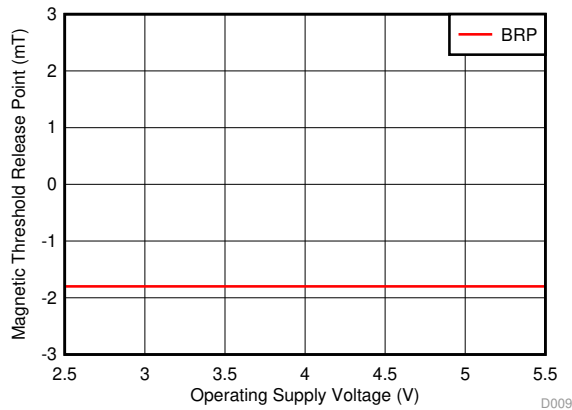
### 8.1 Overview

The DRV5015 is a magnetic sensor with a digital output that latches the most recent pole measured. During power-up, in the absence of an external magnetic field, the DRV5015A1 and DRV5015A2 default to a low output state and the DRV5015A3 defaults to a high output state. Applying a south magnetic pole near the top of the package causes the DRV5015A1 and DRV5015A2 output to drive low, whereas a north magnetic pole causes this output to drive high. Applying a south magnetic pole near the top of the package causes the DRV5015A3 output to drive high, whereas a north magnetic pole causes this output to drive low. The absence of a magnetic field causes the output to continue to drive the current state, whether low or high.

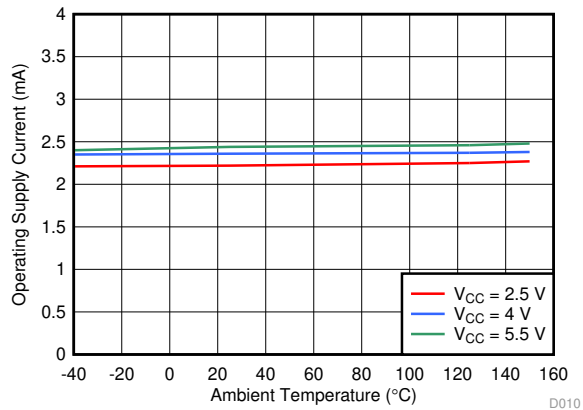
The device integrates a Hall effect element, analog signal conditioning, offset cancellation circuits, amplifiers, and comparators. These features provide stable performance across a wide temperature range and resistance to mechanical stress.

### 8.2 Functional Block Diagram

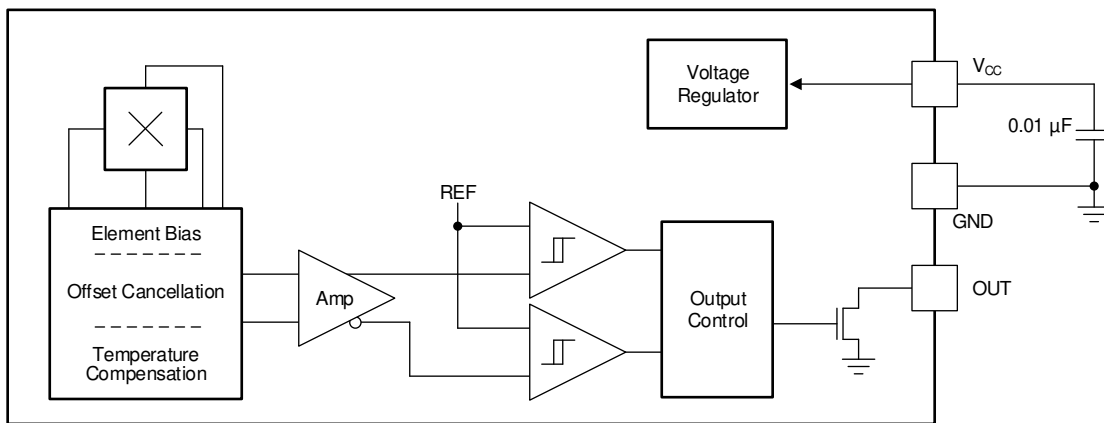

### 8.3 Feature Description

#### 8.3.1 Magnetic Flux Direction

As shown in [Figure 11](#), the DRV5015 is sensitive to the magnetic field component that is perpendicular to the top of the package.

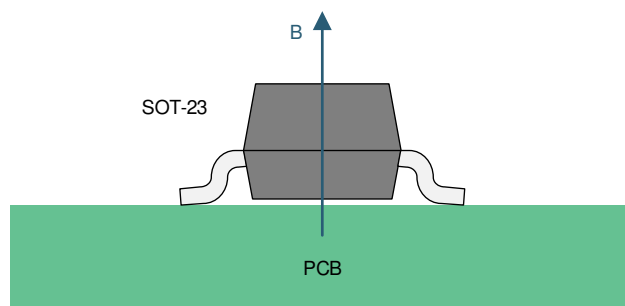
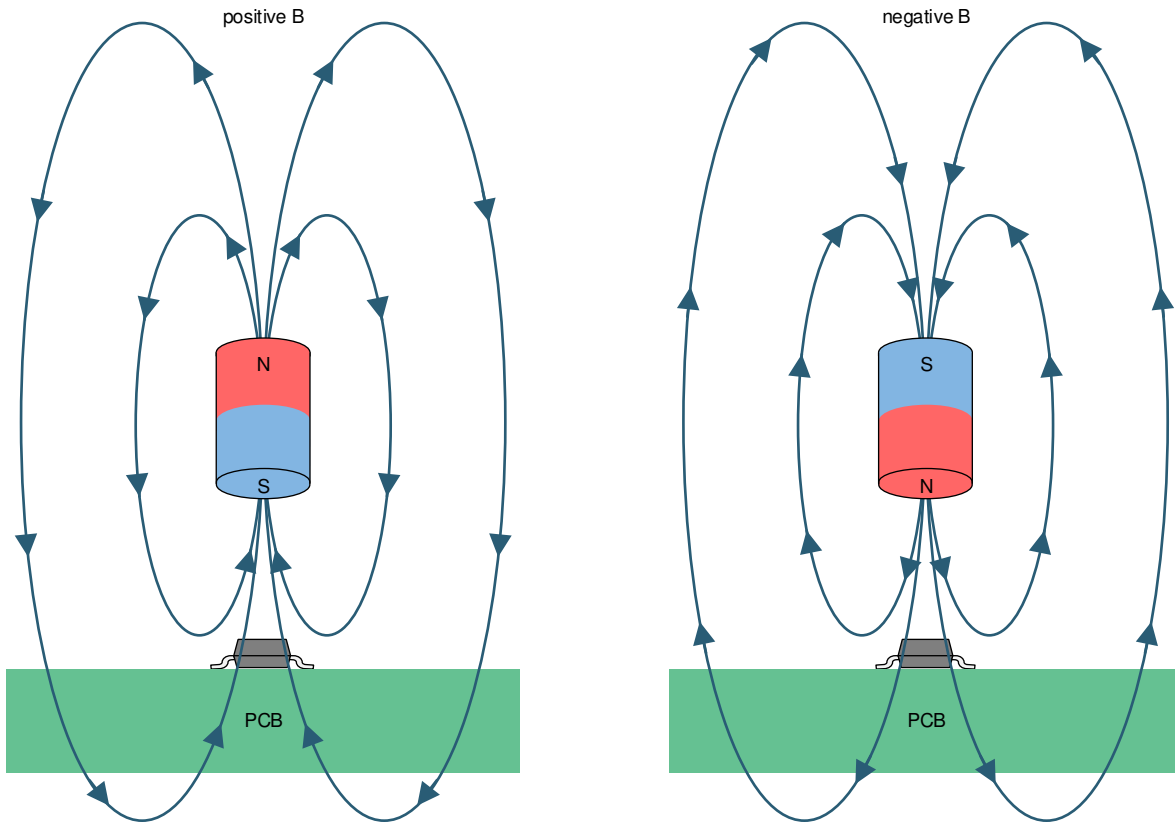

**Figure 11. Direction of Sensitivity**



**Feature Description (continued)**

Magnetic flux that travels from the bottom to the top of the package is considered positive in this document. This condition exists when a south magnetic pole is near the top of the package. Magnetic flux that travels from the top to the bottom of the package is considered negative.  12 shows the flux direction polarity.



 12. Flux Direction Polarity

**Feature Description (continued)**

**8.3.2 Magnetic Response**

Figure 13 shows the device output response to stimulus and hysteresis.

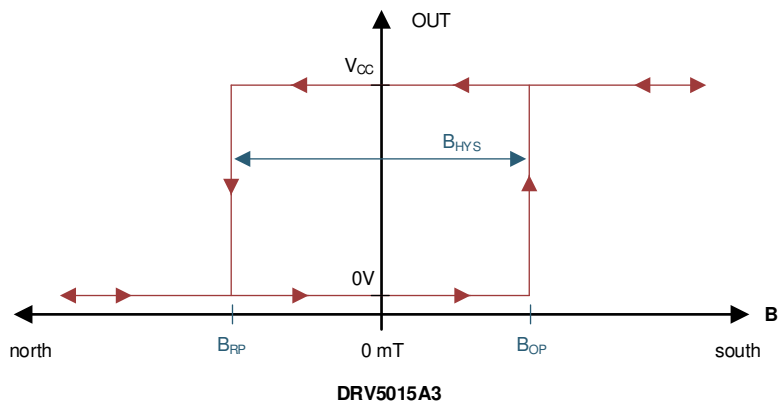
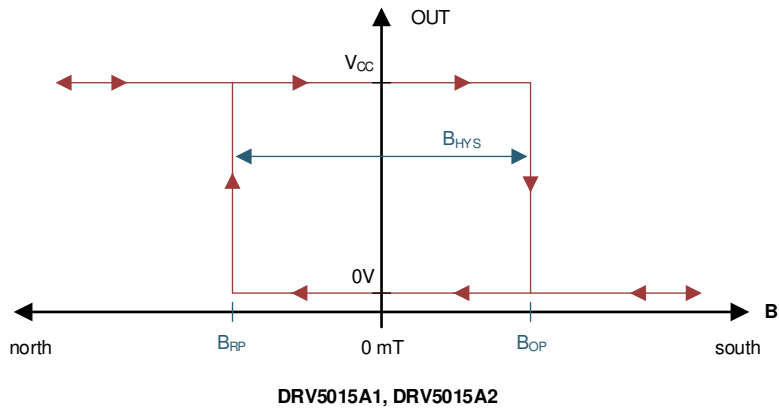

**Figure 13. Device Output Response to Stimulus**

## Feature Description (continued)

### 8.3.3 Output Driver

Figure 14 shows the DRV5015 open-drain output structure. An open-drain output offers flexibility by enabling system designers to interface to wide-range GPIO termination voltages. C1 represents the input capacitance of the GPIO. R1 represents the pullup resistor connected to the termination voltage,  $V_{PULL\_UP}$ . The maximum allowable value of  $V_{PULL\_UP}$  is 5.5 V. The value of R1 must be selected after proper considerations among the system speed and the power dissipation through the pullup resistor.

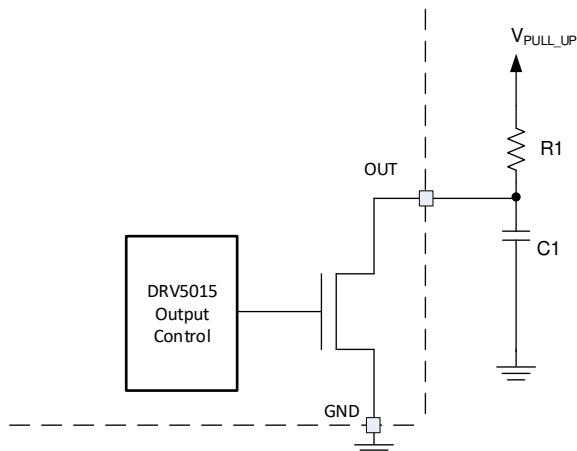

Figure 14. Open-Drain Output (Simplified)

### 8.3.4 Power-On Time

Figure 15 shows that after the  $V_{CC}$  voltage is applied, the DRV5015 measures the magnetic field and sets the output within the  $t_{ON}$  time.

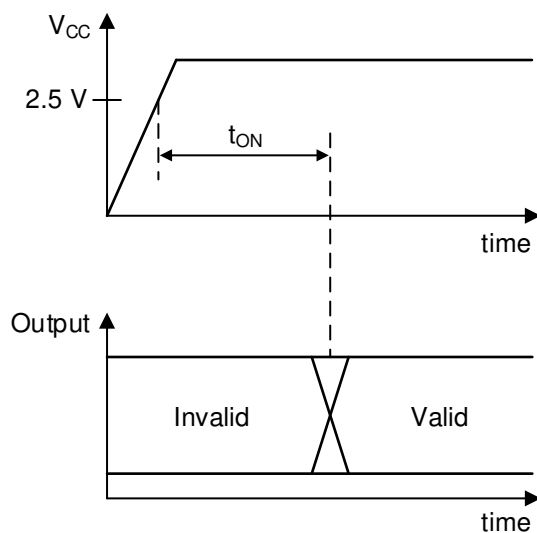
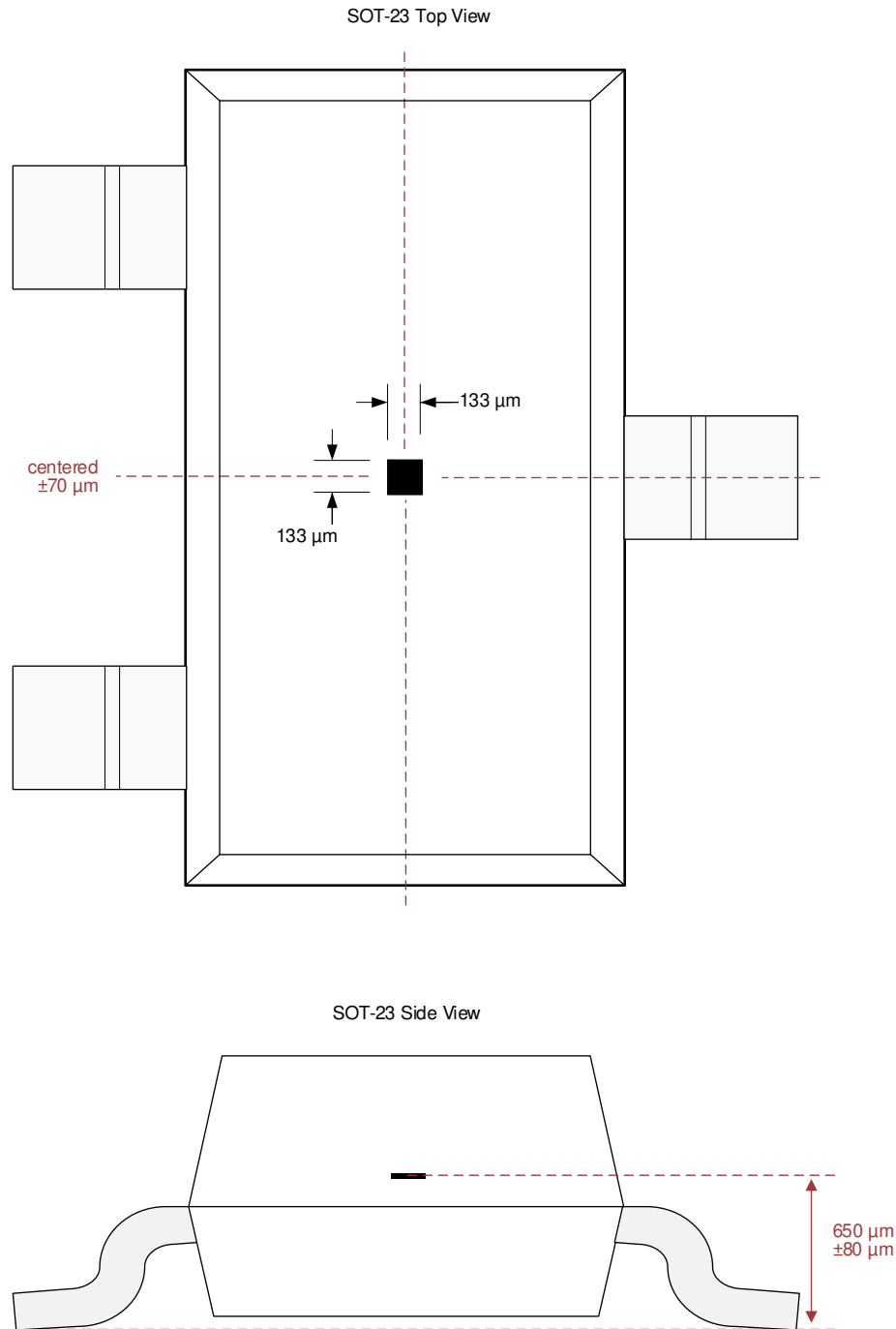

Figure 15.  $t_{ON}$  Definition

**Feature Description (continued)**

**8.3.5 Hall Element Location**

The sensing element inside the device is in the center of both packages when viewed from the top. [Figure 16](#) shows the tolerances and side-view dimensions.



**Figure 16. Hall Element Location**

**Feature Description (continued)**

**8.3.6 Propagation Delay**

The DRV5015 samples the Hall element at a nominal sampling interval of every 16.67 μs to detect the presence of a magnetic north or south pole. At each sampling point, the device takes the average of the current sampled value and immediately preceding sampled value of the magnetic field. If this average value crosses the B<sub>OP</sub> or B<sub>RP</sub> threshold, the device output changes to the corresponding state as defined by the [Overview](#) section.

Figure 17 shows the DRV5015A1 propagation delay analysis in the proximity of a magnetic south pole. The Hall element of the DRV5015 experiences an increasing magnetic field as a magnetic south pole approaches near the device. At time t<sub>2</sub>, the average magnetic field is (B<sub>2</sub> + B<sub>1</sub>) / 2, which is below the B<sub>OP</sub> threshold of the device. At time t<sub>3</sub>, the actual magnetic field has crossed the B<sub>OP</sub> threshold. However, the average (B<sub>3</sub> + B<sub>2</sub>) / 2 is still less than the B<sub>OP</sub> threshold. As such, the device waits for next sample time, t<sub>4</sub>, to start the output transition through the analog signal chain. The propagation delay, t<sub>d</sub>, is measured as the delay from the time the magnetic field crosses the B<sub>OP</sub> threshold to the time output transitions.

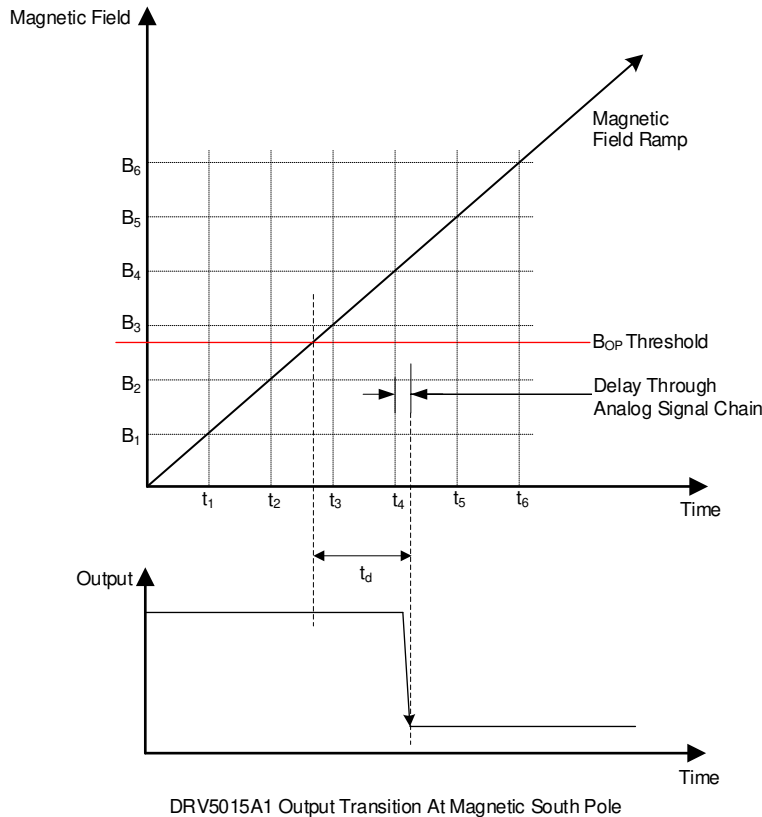

**Figure 17. Propagation Delay**

**8.4 Device Functional Modes**

The DRV5015 has one mode of operation that applies when the are met.

## 9 Application and Implementation

注

Information in the following applications sections is not part of the TI component specification, and TI does not warrant its accuracy or completeness. TI's customers are responsible for determining suitability of components for their purposes. Customers should validate and test their design implementation to confirm system functionality.

### 9.1 Application Information

The DRV5015 is ideal for use in rotary applications for brushless DC (BLDC) motor sensors or incremental rotary encoding.

For reliable functionality, the magnet must apply a flux density at the sensor greater than the corresponding maximum  $B_{OP}$  or  $B_{RP}$  numbers specified in the table. Add additional margin to account for mechanical tolerance, temperature effects, and magnet variation. Magnets generally produce weaker fields as temperature increases.

### 9.2 Typical Applications

#### 9.2.1 BLDC Motor Sensors Application



图 18. BLDC Motor System

##### 9.2.1.1 Design Requirements

Use the parameters listed in 表 1 for this design.

表 1. Design Parameters

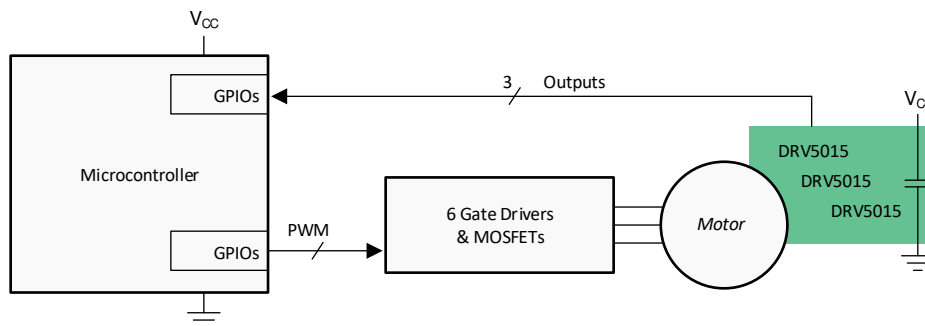
DESIGN PARAMETER	EXAMPLE VALUE
Number of motor phases	3
Motor RPM	15 kRPM
Number of magnet poles on the rotor	12
Magnetic material	Bonded neodymium
Maximum temperature inside the motor	125°C
Magnetic flux density peaks at the Hall sensors at maximum temperature	±11 mT
Hall sensor $V_{CC}$	5 V ± 10%

**9.2.1.2 Detailed Design Procedure**

Three-phase brushless DC motors often use three Hall effect latch devices to measure the electrical angle of the rotor and tell the controller how to drive the three wires. These wires connect to electromagnet windings, which generate magnetic fields that apply forces to the permanent magnets on the rotor.

Space the three Hall sensors across the printed-circuit board (PCB) so that these sensors are 120 electrical degrees apart. This configuration creates six 3-bit states with equal time duration for each electrical cycle, which consists of one north and one south magnetic pole. From the center of the motor axis, the number of degrees to space each sensor equals  $2 / [number\ of\ poles] \times 120^\circ$ . In this design example, the first sensor is placed at  $0^\circ$ , the second sensor is placed  $20^\circ$  rotated, and the third sensor is placed  $40^\circ$  rotated. Alternatively, a  $3\times$  degree offset can be added or subtracted to any sensor, meaning that the third sensor can alternatively be placed at  $40^\circ - (3 \times 20^\circ) = -20^\circ$ .

**9.2.1.3 Application Curve**

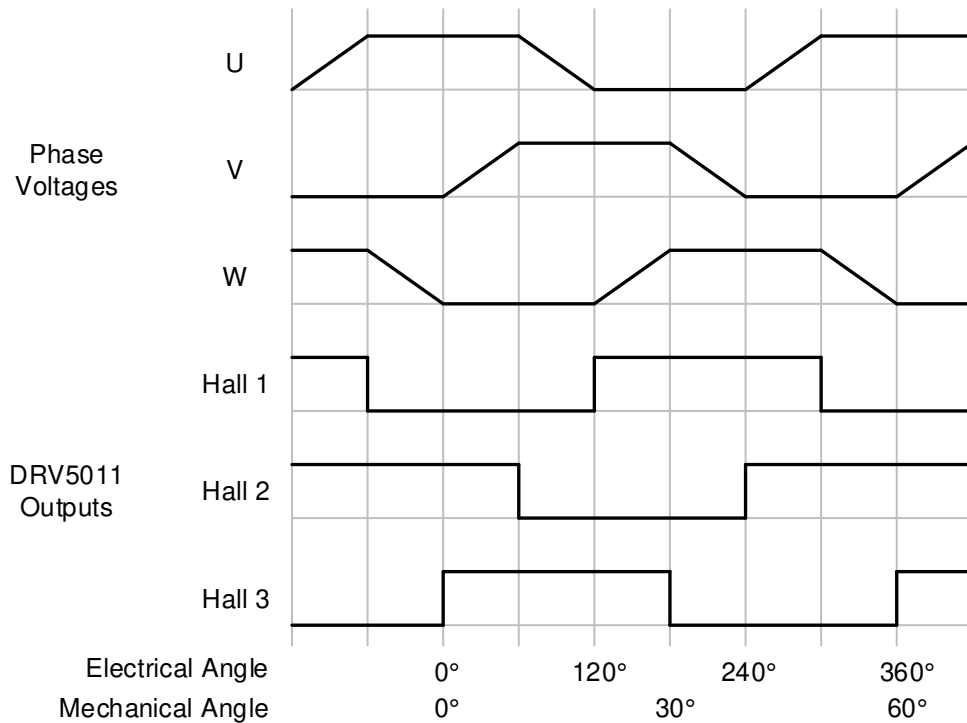

**Figure 19. Phase Voltages and Hall Signals for a 3-Phase BLDC Motor**

## 9.2.2 Incremental Rotary Encoding Application



图 20. Incremental Rotary Encoding System

### 9.2.2.1 Design Requirements

Use the parameters listed in 表 2 for this design.

表 2. Design Parameters

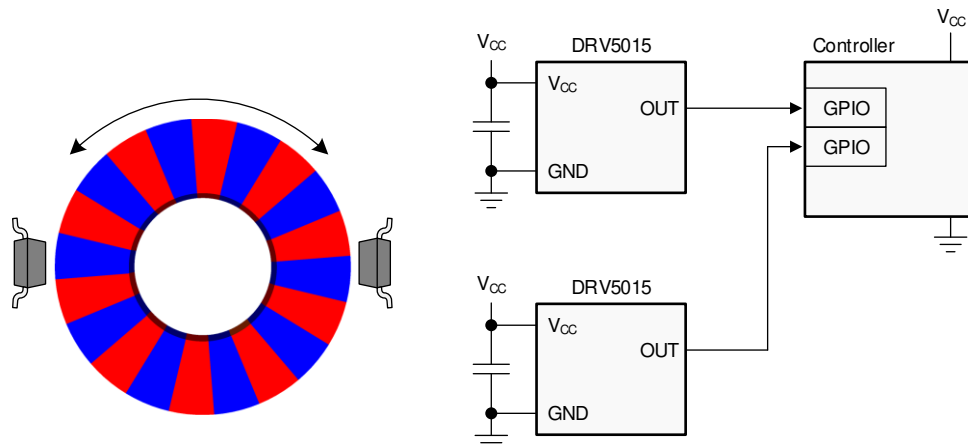
DESIGN PARAMETER	EXAMPLE VALUE
RPM range	45 kRPM
Number of magnet poles	8
Magnetic material	Ferrite
Air gap above the Hall sensors	2.5 mm
Magnetic flux density peaks at the Hall sensors at maximum temperature	±7 mT

### 9.2.2.2 Detailed Design Procedure

Incremental encoders are used on knobs, wheels, motors, and flow meters to measure relative rotary movement. By attaching a ring magnet to the rotating component and placing a DRV5015 nearby, the sensor generates voltage pulses as the magnet turns. If directional information is also needed (clockwise versus counterclockwise), a second DRV5015 can be added with a phase offset, and then the order of transitions between the two signals describes the direction.

Creating this phase offset requires spacing the two sensors apart on the PCB, and an ideal 90° quadrature offset is attained when the sensors are separated by half the length of each magnet pole, plus any integer number of pole lengths. 图 20 shows this configuration because the sensors are 1.5 pole lengths apart. One of the sensors changes its output every  $360^\circ / 8 \text{ poles} / 2 \text{ sensors} = 22.5^\circ$  of rotation. For reference, the [TIDA-00480 TI Design Considerations Automotive Hall Sensor Rotary Encoder](#) uses a 66-pole magnet with changes every 2.7°.

The maximum rotational speed that can be measured is limited by the sensor bandwidth. Generally, the bandwidth must be faster than two times the number of poles per second. In this design example, the maximum speed is 45000 RPM, which involves 6000 poles per second. The DRV5015 sensing bandwidth is typically 30 kHz, which is five times the pole frequency. In systems where the sensor sampling rate is close to two times the number of poles per second, most of the samples measure a magnetic field that is significantly lower than the peak value, because the peaks only occur when the sensor and pole are perfectly aligned. In this case, add margin by applying a stronger magnetic field that has peaks significantly higher than the maximum  $B_{OP}$ .



### 9.2.2.3 Application Curve

Two signals in quadrature provide movement and direction information.  21 shows how each 2-bit state has unique adjacent 2-bit states for clockwise and counterclockwise.

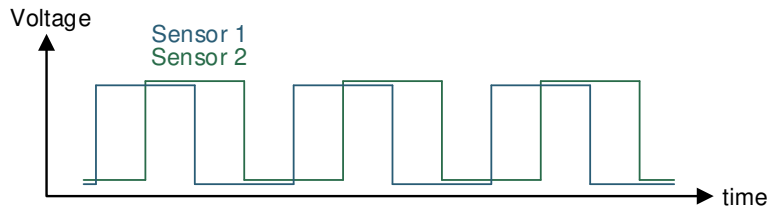

 21. Quadrature Output (2-Bit)

### 9.3 What to Do and What Not to Do

The Hall element is sensitive to magnetic fields that are perpendicular to the top of the package; therefore, the correct magnet orientation must be used for the sensor to detect the field.  22 shows correct and incorrect orientations when using a ring magnet.

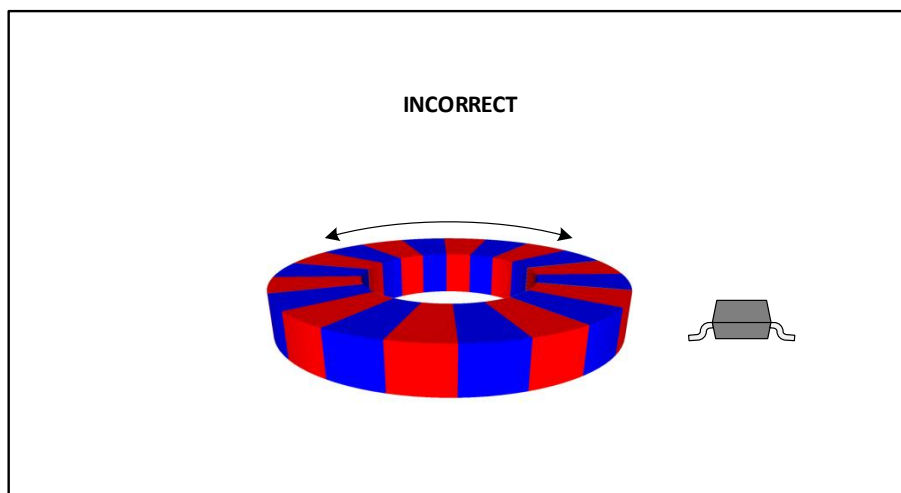
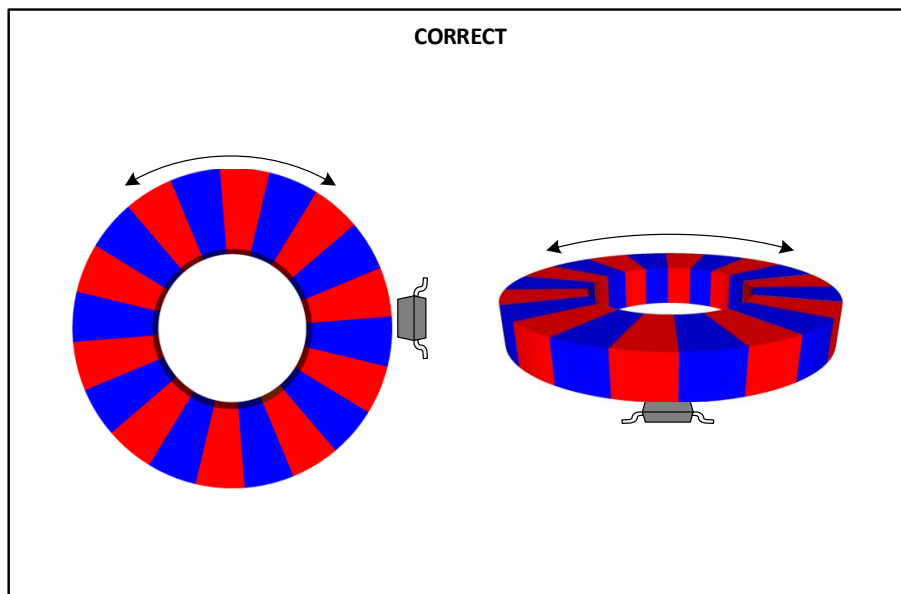

 22. Correct and Incorrect Magnet Orientations

## 10 Power Supply Recommendations

The DRV5015 is powered from 2.5-V to 5.5-V DC power supplies. A decoupling capacitor close to the device must be used to provide local energy with minimal inductance. TI recommends using a ceramic capacitor with a value of at least 0.01  $\mu\text{F}$ .

## 11 Layout

### 11.1 Layout Guidelines

Magnetic fields pass through most nonferromagnetic materials with no significant disturbance. Embedding Hall effect sensors within plastic or aluminum enclosures and sensing magnets on the outside is common practice. Magnetic fields also easily pass through most PCBs, which makes placing the magnet on the opposite side of the PCB possible.

### 11.2 Layout Example

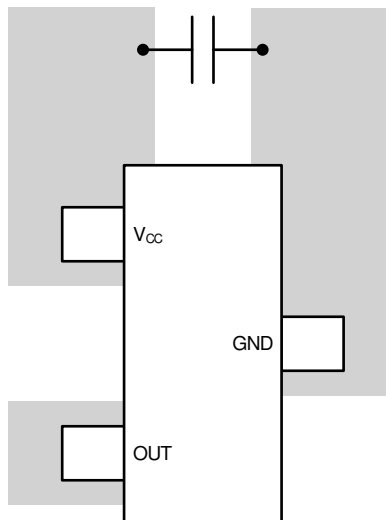

⊗ 23. Example Layout

## 12 デバイスおよびドキュメントのサポート

### 12.1 ドキュメントのサポート

#### 12.1.1 関連資料

関連資料については、以下を参照してください。

- 『[TIDA-00480 車載用ホール・センサ・ロータリー・エンコーダのTI Designの考慮事項](#)』
- 『[HALL-ADAPTER-EVMユーザー・ガイド](#)』

### 12.2 ドキュメントの更新通知を受け取る方法

ドキュメントの更新についての通知を受け取るには、[ti.com](http://ti.com)のデバイス製品フォルダを開いてください。右上の「アラートを受け取る」をクリックして登録すると、変更されたすべての製品情報に関するダイジェストを毎週受け取れます。変更の詳細については、修正されたドキュメントに含まれている改訂履歴をご覧ください。

### 12.3 コミュニティ・リソース

The following links connect to TI community resources. Linked contents are provided "AS IS" by the respective contributors. They do not constitute TI specifications and do not necessarily reflect TI's views; see TI's [Terms of Use](#).

**TI E2E™ Online Community** *TI's Engineer-to-Engineer (E2E) Community*. Created to foster collaboration among engineers. At [e2e.ti.com](http://e2e.ti.com), you can ask questions, share knowledge, explore ideas and help solve problems with fellow engineers.

**Design Support** *TI's Design Support* Quickly find helpful E2E forums along with design support tools and contact information for technical support.

### 12.4 商標

E2E is a trademark of Texas Instruments.

All other trademarks are the property of their respective owners.

### 12.5 静電気放電に関する注意事項



すべての集積回路は、適切なESD保護方法を用いて、取扱いと保存を行うようにして下さい。

静電気放電はわずかな性能の低下から完全なデバイスの故障に至るまで、様々な損傷を与えます。高精度の集積回路は、損傷に対して敏感であり、極めてわずかなパラメータの変化により、デバイスに規定された仕様に適合しなくなる場合があります。

### 12.6 Glossary

[SLYZ022](#) — *TI Glossary*.

This glossary lists and explains terms, acronyms, and definitions.

## 13 メカニカル、パッケージ、および注文情報

以降のページには、メカニカル、パッケージ、および注文に関する情報が記載されています。この情報は、そのデバイスについて利用可能な最新のデータです。このデータは予告なく変更されることがあり、ドキュメントが改訂される場合もあります。本データシートのブラウザ版を使用されている場合は、画面左側の説明をご覧ください。

## PACKAGING INFORMATION

Orderable Device	Status (1)	Package Type	Package Drawing	Pins	Package Qty	Eco Plan (2)	Lead finish/ Ball material (6)	MSL Peak Temp (3)	Op Temp (°C)	Device Marking (4/5)	Samples
DRV5015A1QDBZR	ACTIVE	SOT-23	DBZ	3	3000	RoHS & Green	SN	Level-1-260C-UNLIM	-40 to 125	15A1	<a href="#">Samples</a>
DRV5015A1QDBZT	OBSOLETE	SOT-23	DBZ	3		TBD	Call TI	Call TI	-40 to 125	15A1	
DRV5015A2QDBZR	ACTIVE	SOT-23	DBZ	3	3000	RoHS & Green	SN	Level-1-260C-UNLIM	-40 to 125	15A2	<a href="#">Samples</a>
DRV5015A2QDBZT	OBSOLETE	SOT-23	DBZ	3		TBD	Call TI	Call TI	-40 to 125	15A2	
DRV5015A3QDBZR	ACTIVE	SOT-23	DBZ	3	3000	RoHS & Green	SN	Level-1-260C-UNLIM	-40 to 125	15A3	<a href="#">Samples</a>
DRV5015A3QDBZT	OBSOLETE	SOT-23	DBZ	3		TBD	Call TI	Call TI	-40 to 125	15A3	

(1) The marketing status values are defined as follows:

**ACTIVE:** Product device recommended for new designs.

**LIFEBUY:** TI has announced that the device will be discontinued, and a lifetime-buy period is in effect.

**NRND:** Not recommended for new designs. Device is in production to support existing customers, but TI does not recommend using this part in a new design.

**PREVIEW:** Device has been announced but is not in production. Samples may or may not be available.

**OBSOLETE:** TI has discontinued the production of the device.

(2) **RoHS:** TI defines "RoHS" to mean semiconductor products that are compliant with the current EU RoHS requirements for all 10 RoHS substances, including the requirement that RoHS substance do not exceed 0.1% by weight in homogeneous materials. Where designed to be soldered at high temperatures, "RoHS" products are suitable for use in specified lead-free processes. TI may reference these types of products as "Pb-Free".

**RoHS Exempt:** TI defines "RoHS Exempt" to mean products that contain lead but are compliant with EU RoHS pursuant to a specific EU RoHS exemption.

**Green:** TI defines "Green" to mean the content of Chlorine (Cl) and Bromine (Br) based flame retardants meet JS709B low halogen requirements of <=1000ppm threshold. Antimony trioxide based flame retardants must also meet the <=1000ppm threshold requirement.

(3) MSL, Peak Temp. - The Moisture Sensitivity Level rating according to the JEDEC industry standard classifications, and peak solder temperature.

(4) There may be additional marking, which relates to the logo, the lot trace code information, or the environmental category on the device.

(5) Multiple Device Markings will be inside parentheses. Only one Device Marking contained in parentheses and separated by a "~" will appear on a device. If a line is indented then it is a continuation of the previous line and the two combined represent the entire Device Marking for that device.

(6) Lead finish/Ball material - Orderable Devices may have multiple material finish options. Finish options are separated by a vertical ruled line. Lead finish/Ball material values may wrap to two lines if the finish value exceeds the maximum column width.

**Important Information and Disclaimer:** The information provided on this page represents TI's knowledge and belief as of the date that it is provided. TI bases its knowledge and belief on information provided by third parties, and makes no representation or warranty as to the accuracy of such information. Efforts are underway to better integrate information from third parties. TI has taken and continues to take reasonable steps to provide representative and accurate information but may not have conducted destructive testing or chemical analysis on incoming materials and chemicals. TI and TI suppliers consider certain information to be proprietary, and thus CAS numbers and other limited information may not be available for release.

In no event shall TI's liability arising out of such information exceed the total purchase price of the TI part(s) at issue in this document sold by TI to Customer on an annual basis.

**OTHER QUALIFIED VERSIONS OF DRV5015 :**

- Automotive : [DRV5015-Q1](#)

NOTE: Qualified Version Definitions:

- Automotive - Q100 devices qualified for high-reliability automotive applications targeting zero defects

**TAPE AND REEL INFORMATION**

**QUADRANT ASSIGNMENTS FOR PIN 1 ORIENTATION IN TAPE**

\*All dimensions are nominal

Device	Package Type	Package Drawing	Pins	SPQ	Reel Diameter (mm)	Reel Width W1 (mm)	A0 (mm)	B0 (mm)	K0 (mm)	P1 (mm)	W (mm)	Pin1 Quadrant
DRV5015A1QDBZR	SOT-23	DBZ	3	3000	180.0	8.4	3.2	2.85	1.3	4.0	8.0	Q3
DRV5015A2QDBZR	SOT-23	DBZ	3	3000	180.0	8.4	3.2	2.85	1.3	4.0	8.0	Q3
DRV5015A3QDBZR	SOT-23	DBZ	3	3000	178.0	9.0	3.15	2.77	1.22	4.0	8.0	Q3

**TAPE AND REEL BOX DIMENSIONS**

\*All dimensions are nominal

Device	Package Type	Package Drawing	Pins	SPQ	Length (mm)	Width (mm)	Height (mm)
DRV5015A1QDBZR	SOT-23	DBZ	3	3000	210.0	185.0	35.0
DRV5015A2QDBZR	SOT-23	DBZ	3	3000	210.0	185.0	35.0
DRV5015A3QDBZR	SOT-23	DBZ	3	3000	180.0	180.0	18.0







# EXAMPLE STENCIL DESIGN

DBZ0003A

SOT-23 - 1.12 mm max height

SMALL OUTLINE TRANSISTOR

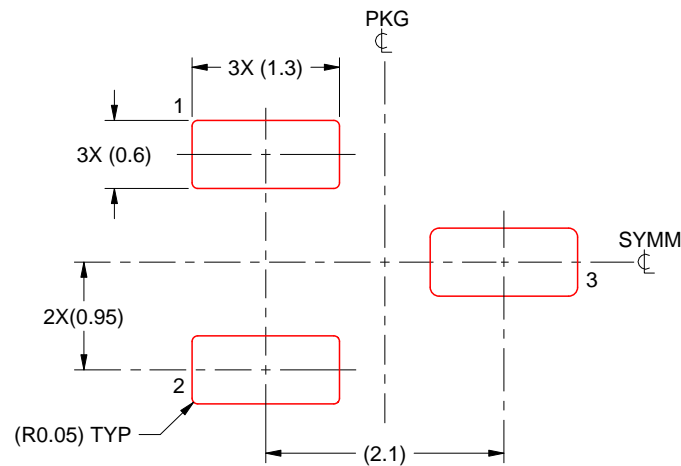

SOLDER PASTE EXAMPLE  
BASED ON 0.125 THICK STENCIL  
SCALE:15X

4214838/F 08/2024

NOTES: (continued)

7. Laser cutting apertures with trapezoidal walls and rounded corners may offer better paste release. IPC-7525 may have alternate design recommendations.
8. Board assembly site may have different recommendations for stencil design.

## 重要なお知らせと免責事項

TI は、技術データと信頼性データ (データシートを含みます)、設計リソース (リファレンス・デザインを含みます)、アプリケーションや設計に関する各種アドバイス、Web ツール、安全性情報、その他のリソースを、欠陥が存在する可能性のある「現状のまま」提供しており、商品性および特定目的に対する適合性の黙示保証、第三者の知的財産権の非侵害保証を含むいかなる保証も、明示的または黙示的にかかわらず拒否します。

これらのリソースは、TI 製品を使用する設計の経験を積んだ開発者への提供を意図したものです。(1) お客様のアプリケーションに適した TI 製品の選定、(2) お客様のアプリケーションの設計、検証、試験、(3) お客様のアプリケーションに該当する各種規格や、その他のあらゆる安全性、セキュリティ、規制、または他の要件への確実な適合に関する責任を、お客様のみが単独で負うものとします。

上記の各種リソースは、予告なく変更される可能性があります。これらのリソースは、リソースで説明されている TI 製品を使用するアプリケーションの開発の目的でのみ、TI はその使用をお客様に許諾します。これらのリソースに関して、他の目的で複製することや掲載することは禁止されています。TI や第三者の知的財産権のライセンスが付与されている訳ではありません。お客様は、これらのリソースを自身で使用した結果発生するあらゆる申し立て、損害、費用、損失、責任について、TI およびその代理人を完全に補償するものとし、TI は一切の責任を拒否します。

TI の製品は、[TI の販売条件](#)、または [ti.com](#) やかかる TI 製品の関連資料などのいずれかを通じて提供する適用可能な条項の下で提供されています。TI がこれらのリソースを提供することは、適用される TI の保証または他の保証の放棄の拡大や変更を意味するものではありません。

お客様がいかなる追加条項または代替条項を提案した場合でも、TI はそれらに異議を唱え、拒否します。

郵送先住所 : Texas Instruments, Post Office Box 655303, Dallas, Texas 75265  
Copyright © 2024, Texas Instruments Incorporated